



Fire Assay - Laboratory Design

*By Dr. Raj K. Mishra, A-1 Specialized Services and Supply, Inc. & Shri N. Sharma, DFC Ceramics/
Cannon City Ceramics*

©2011 The Bell Group, Inc. All rights reserved.

800.545.6566

riogrande.com



THE **studio**
Rio's blog



FIRE ASSAY - LABORATORY DESIGN

Dr. Raj K. Mishra
A-1 Specialized Services and Supply, Inc.
Croydon, PA, USA

Shri N. Sharma
DFC Ceramics/Cannon City Ceramics
Cannon City, CO, USA

ABSTRACT

Lead (Pb) and litharge (PbO) are extensively used in the fire assaying of precious metals (PM). It is well known that Pb is the best collector of PM. Fire assaying is extensively used in the determination of PM. However, lead is very toxic. The OSHA Permissible Exposure Limit (PEL) set by the standard is 50 micrograms of lead per cubic meter of air ($50\mu\text{g}/\text{m}^3$), averaged over an 8-hour workday. Looking at these stringent standards, it appears that these low exposure levels cannot be achieved without substantial capital expenditure. The fate of lead in fire assaying seems to be the same as that of asbestos. Asbestos possibly is the best high temperature material on the planet. Lack of proper guidelines for safe handling and bad publicity killed the industry.

Many collector metals have been investigated to replace lead but none has been universally accepted. The reasons are obvious. Lead is cheap, has a low melting point and is very easy to handle. Preferential collection of PM in lead and its subsequent separation by simple oxidation of Pb to PbO makes it the metal of choice for fire assaying.

Based on engineering principles and the knowledge of skilled fire assayers, laboratories were designed and operated to meet all the OSHA standards for the laboratory environment and safety of the workers. Years of monitoring of lead in the laboratory and in the assayer's blood samples proved the successful design. The system was designed to have a minimum of capital and energy requirements. The design and operating aspects of this laboratory are discussed.

KEY WORDS

Fire Assay, Lead, Lead Oxide, Litharge, Lead Control, Laboratory Design, OSHA, EPA, Regulations, Lead Collection of Precious Metals, Gold, Silver, Platinum Group Metals, Precious Metals Analysis.

INTRODUCTION

Lead metal (Pb) and litharge are used in fire assaying of gold, silver and the platinum group metals (Pt, Pd, Rh, Ru, Ir, Os). Fire assaying has been cited in the literature since the 12th century A.D. Amazingly, it has not changed very much since then either in theory or practice. Each generation has learned and improved the techniques from the previous one.

Fire assaying is well accepted by the industry. In fact, all the commercial handling and trading depends on it.

“Assay” word comes from old English or French “essai” or “assai” meaning “analysis,” or “fire assay” meaning “high temperature analysis.” The details of fire assaying are widely covered in the books and literature. In this paper, we will concentrate mainly on the toxic nature of lead and its control by design, for the assayer’s health and safety.

HEALTH HAZARDS OF LEAD

Lead can be absorbed into your body by inhalation (breathing) and ingestion (eating). *Lead is not absorbed through your skin.* Once the lead is inhaled or ingested in your body, it is circulated throughout your body and stored in various organs and body tissues. Some of the lead is quickly filtered and excreted from your body and some is not. As the exposure to lead increases, your body will store some, as it cannot excrete all of it. The ill effects of lead poisoning are as follows:

1. Overdose: Condition affecting the brain called “Acute Encephalopathy” – a brain disease that quickly develops into seizure, coma and death from cardio-respiratory arrest.
2. Long-term (chronic) overexposure: Damage to your blood-forming, nervous, urinary and reproductive systems.
3. Some common symptoms of chronic exposure include loss of appetite, metallic taste in the mouth, anxiety, constipation, nausea, pallor, excessive tiredness, weakness, insomnia, headache, nervous irritability, muscle and joint pain or soreness, fine tremors, numbness, dizziness, hyperactivity and colic. In lead colic there may be severe abdominal pain.
4. Chronic overexposure to lead impairs the reproductive systems of both men and women. Overexposure to lead may result in decreased sex drive, impotence and sterility in men.

There is a limit mandated by US governmental agencies for the safety of the workers from lead poisoning. US Occupational Safety and Health Administration (OSHA) Blood Lead (PbB) or Blood Lead Level (BLL) show the amount of lead circulating in the blood stream, not the lead stored in the body. PbB or BLL are reported in micrograms/deciliter ($\mu\text{g}/\text{dl}$) or ($\mu\text{g}/100\text{g}$) of whole blood.

OSHA mandates a PbB or BLL of $40\mu\text{g}/\text{dl}$ (maximum). For those who desire to have healthy babies, PbB should be below $30\mu\text{g}/\text{dl}$. PbBs of $150\mu\text{g}/\text{dl}$ or

higher can cause encephalopathy. Maintain PbB of below 40 $\mu\text{g}/\text{dl}$. The employer has the prime responsibility to ensure that both the company and individual workers comply with the provisions of the standard. The worker, however, also has a responsibility to assist the employer in complying with the standards. After all it is the worker's health that is at stake.

The Center for Disease Control (CDC) mandates even a much stricter level of PbB - 25 $\mu\text{g}/\text{dl}$ of whole blood. For a child, it is lowered to 10 $\mu\text{g}/\text{dl}$.

You have heard the famous saying – “*Nero was fiddling while Rome was burning.*” Recent forensic anthropological research on Roman Emperor Nero's bones proved that Nero had progressively become insane by slow lead poisoning caused by his wine goblet. The goblet was made of pewter. Pewter is an alloy of Pb and Sn. Slow lead poisoning was caused by a very small amount of lead being leached by the wine. In the new formulation of pewter, Pb has been substituted with Sb (antimony).

As more information on the hazardous nature of lead became available, OSHA mandated regulations for work place safety. Basically they are:

Permissible Exposure: The Permissible Exposure Limit (PEL) set by the standard is 50 micrograms of lead per cubic meter of air (50 $\mu\text{g}/\text{m}^3$), averaged over an eight-hour workday.

Action Level: The standard establishes an action level of 30 $\mu\text{g}/\text{m}^3$, Time Weighted Average (TWA), based on an 8-hour workday.

The action level initiates several requirements of the standard, such as exposure monitoring, medical surveillance, training and education.

The initial OSHA requirements look very difficult to achieve but with the proper creation of a ‘look-after-your-own-health’ culture, it is easily achieved. Initially, air monitoring in the laboratory should be performed at least twice a year. But when levels become consistent, then monitoring can be dropped to once a year. The lead blood levels of the assayers should be monitored at least once a year.

LEAD IN THE BLOOD

Lead in blood is caused by either *ingestion* or *inhalation*.

Ingestion of lead is controlled by training and implementation of good hygienic behavior of the assayers. Some of the points are described below:

- No eating or drinking in the laboratory.
- When handling test lead and lead foil for scorification process, use disposable hand gloves. For assayers it is a very good idea to get in the habit of wearing them as long as possible during the entire shift. Disposable gloves fit well to the hand and are not that expensive. The Nitrile disposable gloves do not puncture easily and are well liked by the assayers. They come in various sizes.
- Assayers should always wash their hands and face before eating or drinking.

- Work areas and the floors should be frequently vacuumed. Always use industrial vacuum cleaners with HEPA filters. NILFISK brand or any similar industrial vacuum cleaners should be used. Don't allow any debris accumulation anywhere in the laboratory. It should be in drums and properly labeled either as Non-Hazardous or Contains Lead.
- Use respirators when working near the furnace, and especially whenever the furnace doors are open. Choose the proper type of respirator. The assayers seem to like the disposable respirators better than the cartridge types. Our finding showed that any disposable respirator that can handle solid and liquid aerosols (such as 3M No. 8240) was adequate for the health protection of the assayers.
- Implementation of all the above chores should be the responsibility of the Laboratory Manager, strongly supported by the management. The new procedures should be strictly enforced until they become a routine for the assayers, which can easily take up to a year. If need be, assayers should be given written warnings to show the seriousness of the matter.

Inhalation – Most of the fire assaying laboratory design is to prevent the inhalation of lead dust. The inhalation of lead dust is from the airborne particles. The design and handling procedures require that the lead or lead compounds be captured at the source, before they get disseminated.

DESIGN PARAMETERS

1. Human Elements

- Identify the places where lead dust can be airborne.
- Observe the assaying operation carefully and make notes of operational changes required.
- No matter how good a system is designed, if it makes the operation more complex rather than simplifies it, the design is bound to fail. In fact, the workers will do everything to make sure that the system does not work and make the design engineer look bad in the eyes of management.
- Some operational changes can save money in capital cost expenditure. Discuss the desired operational changes with the assayers and have their consent. Get their input and integrate them in the design of the laboratory. Make them feel a part of the team. Fact is, they know the operations much better than anybody else. Even if you know the answer, make it appear as if it came from them. Always praise the important contributions made by them in front of their bosses.
- Design the system as if you have to work there eight hours a day for the rest of your life. It is advisable that the design engineer should work as an assayer for a day or two. He will start to see things from a completely different angle.

2. Operational Considerations

All the operations where lead dust can be airborne must be identified and grouped together as shown in Figure 8. It is a typical plot plan for a fire-assaying laboratory.

2.1 Flux and Sample Mixing Tables

2.1.1 Section 1 – Fusion Flux Preparations and Storage

- Additions of flux ingredients in the drum, e.g., litharge, soda ash, silica, borax, etc.
- Storing the prepared flux in the drums
- Taking the flux from drums into the crucibles for assay

2.1.2 Section 2 – Sample and flux mixing

- Transferring the crucibles with flux in the crucible holder tray
- Mixing of flux with the samples to be analyzed

2.1.3 Section 3 – Base Bar Flux Preparation and Storage

- Same as Section 1 except for Base Bar Flux

2.2 Furnace Ventilation

• *Furnace Chamber Exhaust*

The furnace chamber exhaust is part of the furnace design and is specified by the furnace manufacturer. In case of DFC Electric Furnace, it is 300 CFM. The lead fume from the furnace chamber is removed by a high temperature vacuum ejector system. A small fan mounted on top of the furnace supplies the ejector primary air.

• *Furnace Door Exhaust*

During cupellation process, part of the furnace door is kept open. The door is opened completely for insertion and removal of the cupels, crucibles and scorifiers. Some of the hot furnace gases containing PbO_x fumes rise up between the furnace door and the face of furnace. This fume has to be captured before it contaminates the laboratory air.

2.3 Downdraft Table

- After the crucible fusion is complete, either the crucible or the poured melt in a cast iron mold has to be cooled off. During the cooling off of this molten slag and lead, Pb fumes are given off. The downdraft table captures these lead fumes.
- After the cupellation or scorification process, the hot cupels and scorifiers emit lead fumes during the cooling off period. This downdraft table is the place to capture the fumes during this period.

2.4 Anvil Table

- The separation of slag from the lead button requires hammering of the solidified crucible, scorifier or the slag/lead button from the mold. Hammering shatters the slag like glass. The lead button is separated

and cleaned and hammered into a cube for cupellation. Lead-containing dust is generated and collected in this section.

- The lead-containing slag, dust, used crucibles and scorifiers are all collected in a drum, under proper ventilation, from this table.

OVERALL DESIGN CONSIDERATIONS

1. **Modular Type** – Generally, the secondary precious metal refiners use two types of fusion fluxes, i.e., Sweeps and Base Bar. The system should be of modular design. Modules can be added or subtracted as desired. For example, if three different types of fusion fluxes are used, increase the storage sections to three and mixing sections to two, etc.
2. **Material of Construction** – In fabricating the various tables and the ductwork, the labor cost is the predominant factor rather than the material of construction. The material cost difference between Stainless Steel 304 and carbon steel is not very significant considering the advantages. The stainless steel shows even small amounts of leaded dirt build-up clearly, and therefore is easy to clean. Stainless Steel 304 should be the material of choice.
3. **Downdraft Table** – Keep the downdraft table as close to the furnace as possible.
4. **Air Volume Control** – A simpler approach to ventilation could be to totally enclose or canopy all the lead fumes-producing processes. But in that case the air volume required for ventilation becomes very large. In our view, it is overkill and is a highly energy-inefficient design.

Keep the minimum open work area on the tables and keep the system enclosed with removable and hinged lids. Lead has high density and therefore requires high capture velocities for fluidization. The larger the open areas on the table, the higher will be the air volume requirements, which translates into larger ducts, fans, bag houses and energy requirements. The system will become unnecessarily very expensive.

When designing the tables with lids, it should cause minimum inconvenience to the assayers. Rather, it should help them in their daily work. The lids should be made removable and with piano-type hinges.

5. **Makeup air** – In spite of minimizing the air volume by covering the tabletops, it is still quite significant in the fire assay room. Always provide the makeup air for the room (or the room will be under a negative pressure).
6. **Two Ducts System** – Design should include two lines of duct systems. The first line should be for the furnaces and downdraft tables, and the second line should be for the mixing and anvil tables.

Furnace duct system works continuously while the other system can be turned on or off as required.

7. **Wet Chemistry Laboratory** – Isolate the wet chemistry section from all the delicate equipment (such as ICP, weighing scale, etc.) in the laboratory. The

corrosive fumes attack the delicate instruments. If there are space constraints, weighing and fire assaying can be combined in the same room but definitely keep the wet chemistry section separate.

8. **One shift operation** – If the company runs either a one or two shifts operation, the ventilation system can be turned off after the working hours. The furnaces should be turned down to coast at 600°C (1112°F) during the night and turned on two hours before the shift starts. This way, the furnaces are at the desired temperature before the shift starts. This can be achieved by simply installing a timer on the furnaces. Shutting down the furnaces completely during the night and turning them on in the morning has a couple of major disadvantages. It shortens the refractory life due to thermal shock and causes the furnace lining to be changed quite often. Also, two to three hours of time are lost each working day for the furnaces to reach the assaying temperature every morning.
9. **Cleanout Ports** – The duct systems should include sufficient numbers of cleanout ports.

ENGINEERING DESIGN

1. Air Velocities

The most important factor in designing a good ventilation system is to determine the face velocities and duct velocities. Both are dependent on the bulk density and size of the material. Entry (face, capture) velocity is important because the dust particles are swept away inside the duct before they have a chance to escape and contaminate the laboratory. The proper duct velocity prevents the particles from settling and clogging the duct system. The conveying velocity is a function of bulk density and the particle size of the material. Figure 1 shows the inter-relationship of the conveying velocity with the bulk density and the particle size. Try to determine the bulk density and the particle size distribution of the material physically in the laboratory. If it is not possible, then, use the published data from the available literature. Bulk density^{1,2,3,4,5,6} and conveying velocity² of some common materials are shown in Table 1.

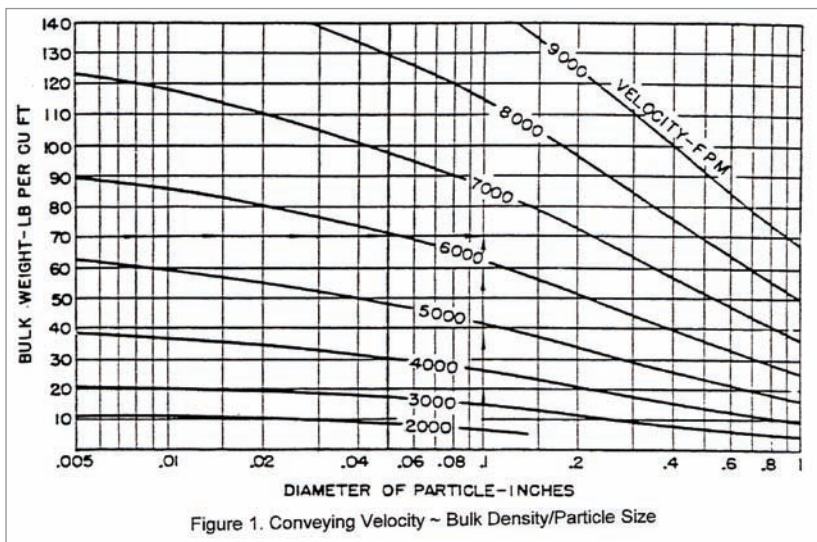

Figure 1 Conveying velocity - bulk density/particle size

Table 1 Bulk density and conveying velocity of materials

Material	Bulk Density (lb/ft ³)	Velocity (fpm)	Material	Bulk Density (lb/ft ³)	Velocity (fpm)
Castor Beans					
Cement	94 - 116	7000	Wheat	48	5800
Salt	81	5500	Rubber, Ground	23	4500
Iron Oxide	25	6500	Saw Dust, dry	13	3000
Limestone	85	5000	Sand	105	7000
Litharge (Assay)	102	5000	Paper	58	5000
Litharge ³	45.6 - 171.2 ⁶	-	Red Lead ^{3*}	31 - 114	-

*Pb₂O₃

Table 2 is the compilation of all the important velocities used for a successful design of fire assaying laboratory ventilation design.

- From Table 2 it is quite clear that the face velocities vary between 200-350 feet/minute and the duct velocity of 5000 feet/minute is adequate for the design. Laboratory design, based on the above air velocities, was successful in controlling the lead in the workplace environment and complied with all OSHA mandated guidelines for the safety of the workers.

Table 2 Design velocities

Air Entry or Face Parameters						
Description	Face Velocity (ft./min.)	Opening (in. x in.)	Area (ft ²)	Air Volume (CFM)	Duct Velocity (ft./min.)	Ventilation Type
1. Mixing Table						
Fusion Flux	250	14 x 26	2.52	630	5000	Side Draft
Base Bar Flux	250	14 x 26	2.52	630	5000	Side Draft
Sample Mixing	250	14 x 26	2.52	630	5000	Side Draft
2. Downdraft Tables						
Furnace #1 and 2	200	24 x 24	4.00	800	5000	Down Draft
Furnace #2 and 3	200	24 x 24	4.00	800	5000	Down Draft
3. Anvil Table	350	22 x 30	4.58	1600	5000	Side Draft
4. Furnace Ventilation						
Door	350	42 x 10	2.92	1000	5000	Up Draft
Duct	300	6 x 4	0.16	300	5000	Side Entry
Port *	300	<i>Ejector (Vacuum) *</i>		300	1875	Ejector

*Installed by DFC

2. Fire Assay Laboratory Layout Drawing

Figure 2 shows the laboratory ventilation flow diagram with three furnaces, two owndraft tables, one anvil table and one mixing table with three modular sections. The two end sections of the mixing tables are for storage and removal of sweeps and base bar fluxes. The central section is for mixing of fluxes with the samples to be analyzed. These modules can be added and subtracted based on the requirements of a particular laboratory. The air volumes required for theventilation are shown in the drawing.

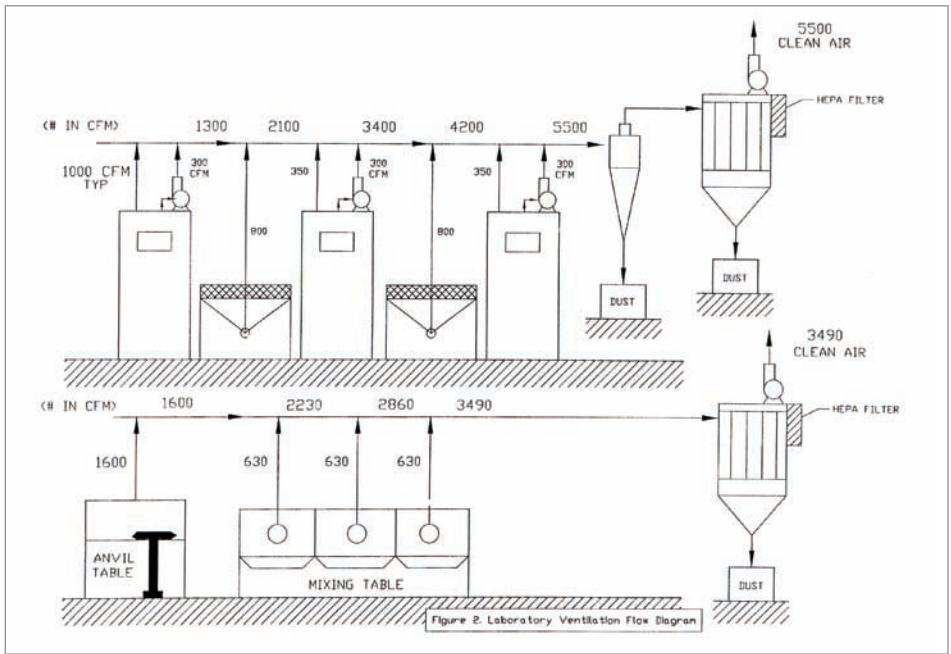

Figure 2 Laboratory ventilation flow diagram

3. Components Design

The drawings of the various components are self-explanatory. However, they will be briefly described as follows.

3.1 Mixing Tables

3.1.1 Typical Section

Figure 3 shows the details of a flux storage section. The 30-gallon drum is placed in a drum dolly and wheeled inside the table. The drum skirt is then placed inside the drum from the top of the table. The skirt hangs inside the drum to prevent the escape of lead dust from the gap between the drum and the table. The dimensions of the components are as follows:

- Table - 26" L x 26" W x 37" H
- All Stainless Steel 304 (SS 304) construction
- 14" H cover
- Heavy duty 30-gallon SS 304 drum
- SS 304 removable skirt with handles.

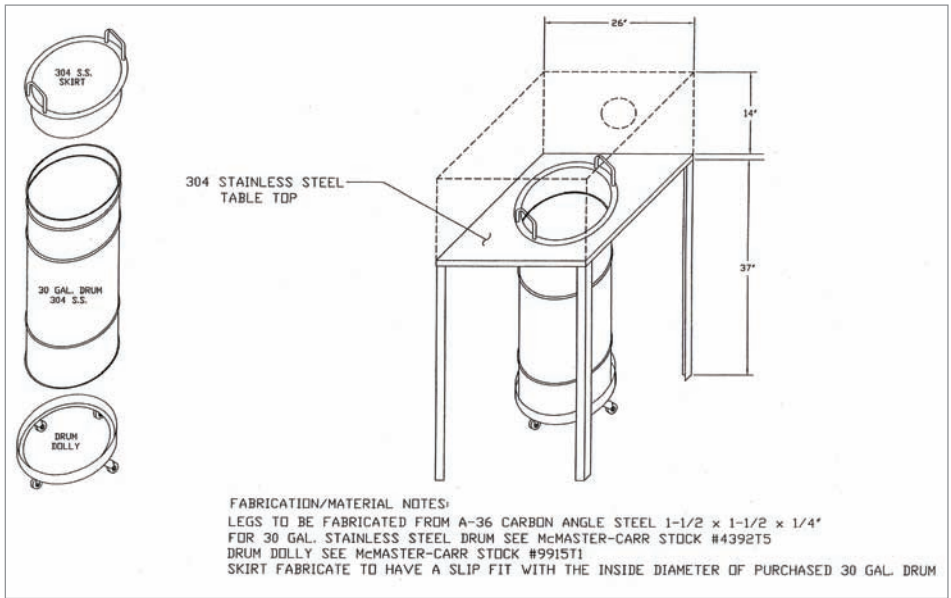

Figure 3 Mixing table - single section

3.1.2 Flux Preparation

In order to prepare the flux, the 30-gallon empty drum is placed in the dolly and wheeled inside the table. The skirt is fitted in. The ventilation system is turned on and the pre-weighed flux components are poured slowly into the drum, one by one. In preparing the flux mix, formulations (such as $x\% \text{PbO}$, $y\% \text{SiO}_2$, etc.) are calculated based on the full pail weight of litharge. The entire pails of litharge are emptied into the drum and other ingredients are added in required proportions. Generally, the litharge is shipped in 50-pound pails. Calculate the formulation based on 50, 100, 150 pounds litharge weight. Make sure the volume of total flux ingredients in the drum fills only $2/3$ of the drum volume. When the correct amounts of fluxes are added in the drum, the skirt is removed from the drum and table. The drum with the dolly is rolled out from under the table. A steel cover (with gasket and ring) is tightly placed on top of the drum. The sealed drum is placed on a drum rotator or mixer to mix the flux ingredients thoroughly. Many exotic types of solid mixers are available but the simplest and cheapest is the stationary drum rotator. Rotating the drum for 12-16 hours on a stationary rotator provides thorough mixing of the flux. Put the drum (mixed flux) back in the dolly. Remove the drum cover and wheel it inside the table. Put the skirt back on to fit inside the drum. You are ready to use the flux for the samples. One can make as many types of fluxes as required and have them individually compartmentalized as shown in Figure 4.

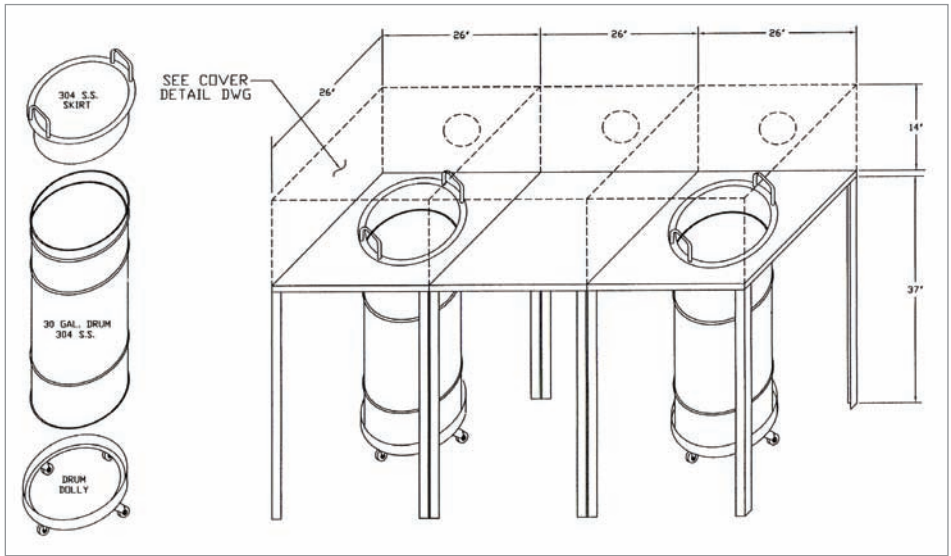

Figure 4 Mixing table - three sections

It is easier to have a common flux sample mixing section put in between the two types of fluxes.

Figure 5 shows the details of the table covers, which minimize the air volume while maintaining the capture and transport velocities. Each sectional cover is divided into two halves, connected together and also to the table with piano-type hinges. The front lid is a see-through heavy duty plastic (plexiglass). The two piano hinges help in completely folding the top cover to insert the skirt in the table, and also to minimize the airflow while transferring (from drums to the crucibles) and mixing the flux and the sample.

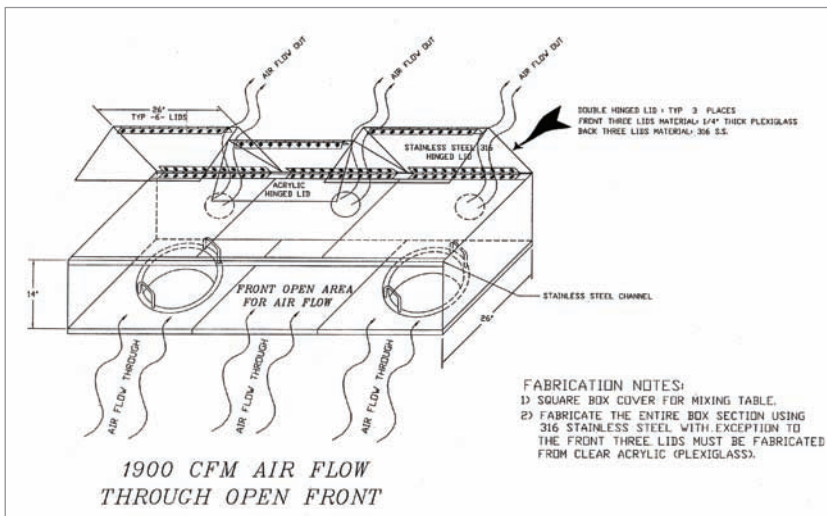

Figure 5 Mixing table - cover design

Mishra

3.2 Furnace Ventilation

3.2.1 Furnace Chamber Exhaust

The furnace chamber exhaust is part of the furnace design and is specified by the manufacturer as discussed earlier.

3.2.2 Furnace Door Exhaust

The DFC furnace manufacturers give the option to buy the manual or electric door opening/closing options. The electric opening option costs slightly more than the manual one. But the electric option is highly preferred as the containment of lead fumes is much better due to vertical opening of the furnace door as compared to the horizontal opening of the manual door.

Figure 6 shows the details of furnace door ventilation. Generally, a two-foot overhang on three sides with the front side width of about 6" is sufficient. The overhang design can be changed to suit the laboratory conditions.

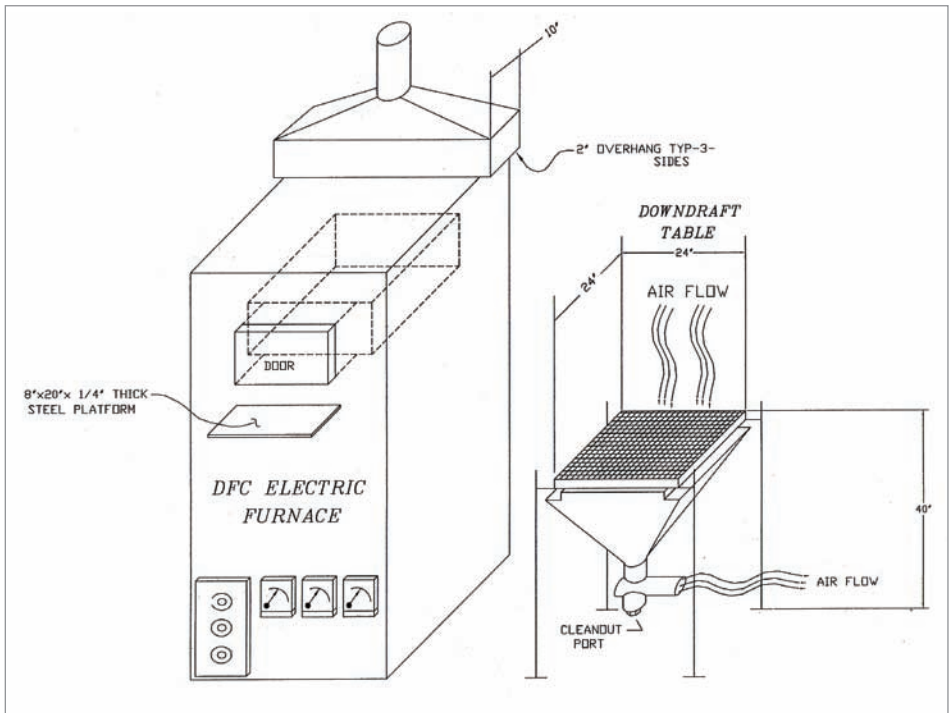

Figure 6 Furnace front ventilation and downdraft table design

3.3 Downdraft Table

Very hot cupels, scorifiers and crucibles are removed from the furnace chamber and placed on a table to cool, where they give off the lead fumes, the major source of lead contamination in the laboratory. A specially designed downdraft table, as shown in Figure 6, prevents lead fume from escaping into the laboratory. The table is 2 ft. x 2 ft. in size and 40 inches high. The top grid is made of a heavy-duty grate that does not warp due to excessive heating and cooling of the cupels, scorifiers and the crucibles. McNichols Company's (www.mcnichols.com) grate GMC-1 (1 inch high x 3/16 inch bearing and cross bar x 7/16 inch spacing) works well.

3.4 Anvil Table

A complete design of the anvil table is shown in Figure 7. The table is 30 in. L x 24 in. W x 40 in. H. An anvil or steel plate is mounted on a pedestal to break the crucibles, scorifiers or Pb-slag buttons to remove the slag. The lead button is cleaned and hammered to form a cube on the anvil. Broken crucibles and scorifiers are then swept inside the empty drum and placed under the table. After the drum is filled, a cover is put on it, and it is stored in a separate section for proper disposal. The leaded cupels are stored in a separate drum for proper disposal or recycling.

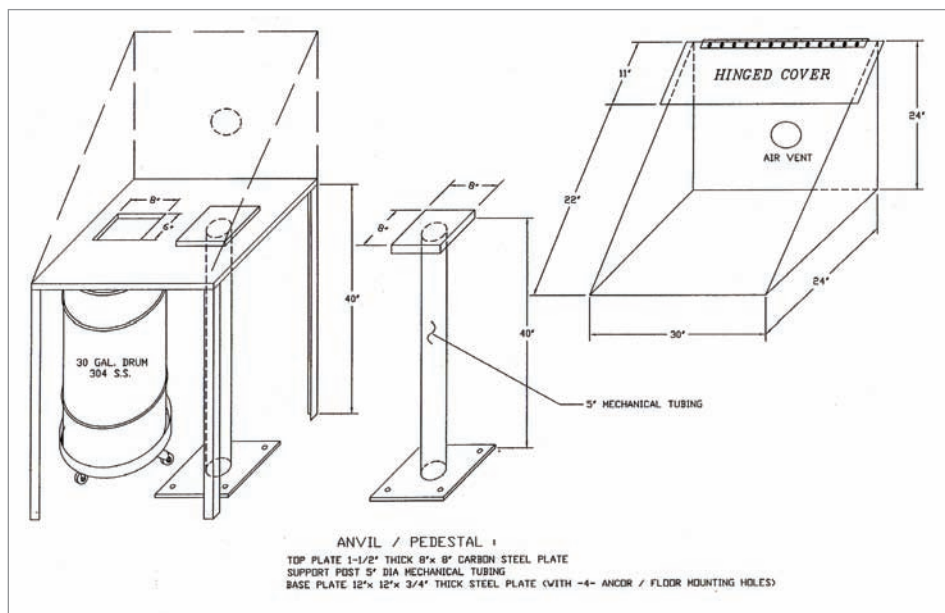

Figure 7 Anvil table design

3.5 Laboratory Layout

There could be many layout configurations of the equipment, depending on the space available in the laboratory. One of the possible equipment layout designs is shown in Figure 8.

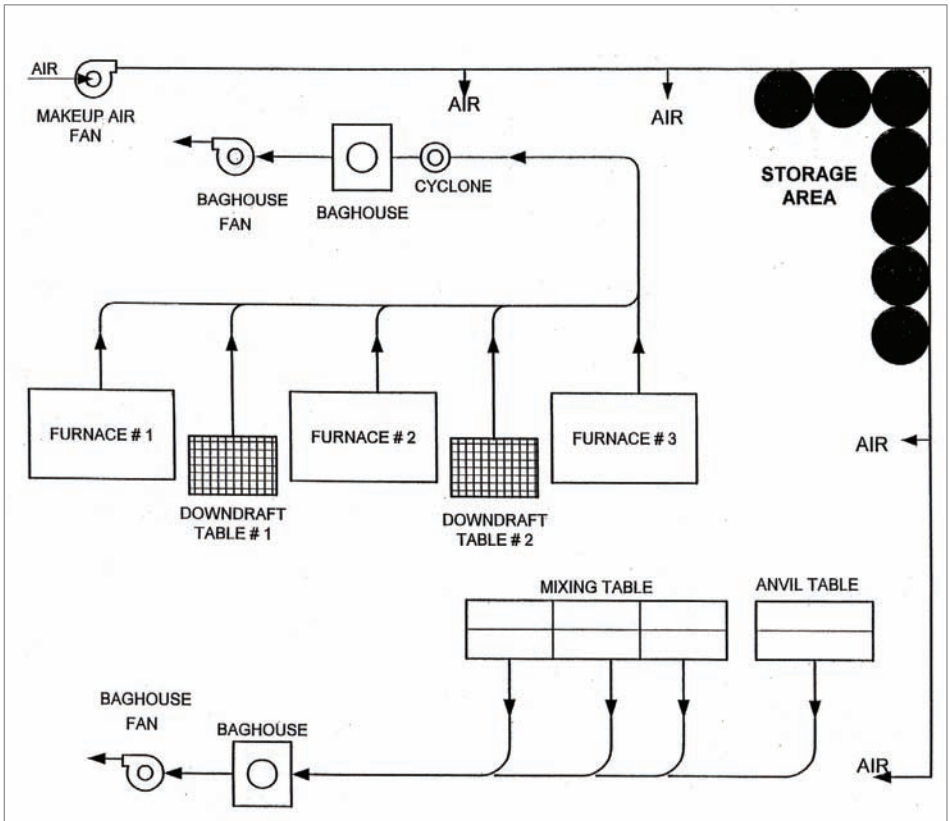

Figure 8 Fire assay laboratory plot plan

3.6 The Fan Selection

As shown in Figure 2, the volume of air through the system increases as more air is introduced from different pickup points. In order to maintain the desired velocity of 500fpm in the pipes, the diameters of the pipes also increase. In order to size the fan or blower, the total pressure drop through the system is calculated, which depends on the length of different size pipes, number of bends, contraction or enlargement of the pipe, sudden entry or exit and flow through the valves. The fan or blower is selected on the total pressure drop ("WC") and the total flow of air (CFM) for each line. The design aim should be to size the system to have minimum pressure drop by keeping the length of piping short, but not too short to burn the bag house down. The temperature reaching the bag house from the furnace line should be below 93°C (200°F). It is always a good idea to make provisions for dilution air prior to entering the bag house. The bag house should have an automatic shaker mechanism with HEPA-type filter before the final exhaust. Provide adequate slide gate valves in different pipes at the air entry points to the system to balance the airflow.

OTHER HELPFUL TOOLS

1. Crucible Holders

It is easy and safe to transport assay crucibles full of leaded material in a properly designed holder. As shown in Figure 9, the holes in the polypropylene sheet prevent the assay crucibles from falling in the tray and spilling the lead-containing flux to the environment.

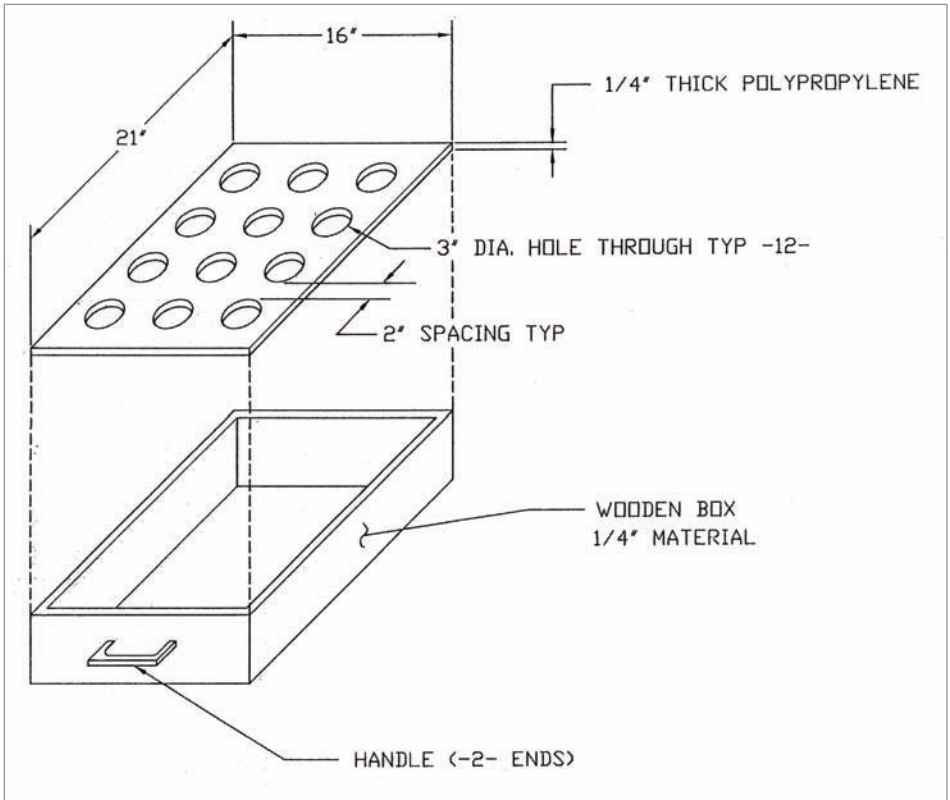

Figure 9 Crucible holder

2. Cupel Transfer Tool

A simple tool design, as shown in Figure 10, can be used to put the cupels in and out of the furnace. A 1/8 inch thick metal plate is used to place the cupels on top of it. The tapered angled plate with a handle picks up the plate with cupels on top of it and then places it inside the furnace. The plate with handle is then pulled out slowly, leaving the cupels on top of the metal plate inside the furnace. The cupels on the metal plate are removed from the furnace by sliding the tapered plate (with handle) under the metal plate with cupels. It is pretty much like a pizza being placed in and removed from the oven.

If the flat metal plate is made of mild steel, it becomes a consumable item as it oxidizes rather quickly. It is recommended to use SS 316L plate, which has a much lower oxidation rate. Even better material for the flat plate is a high temperature alloy, such as Inconel.

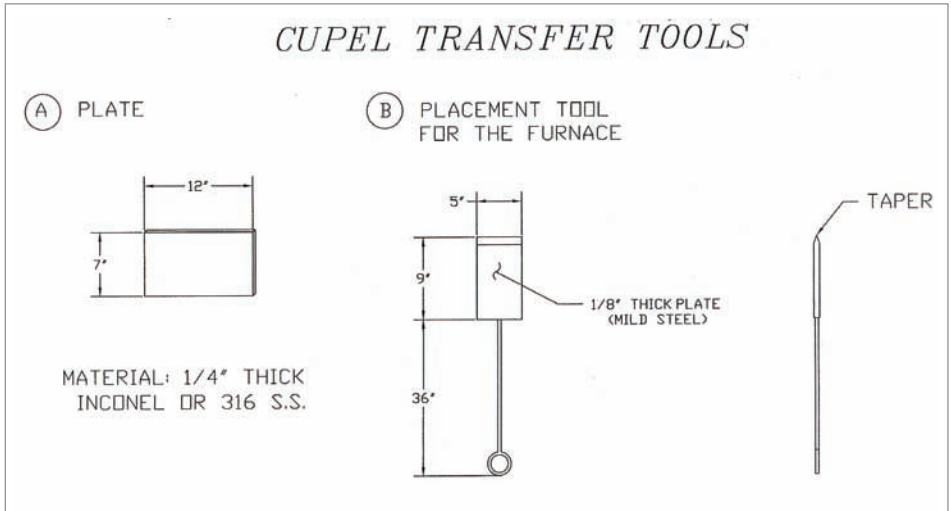

Figure 10 Cupel transfer tool

ACKNOWLEDGEMENTS

Our special thanks go to Mr. Matt Herzing of Canon Industrial Ceramics, LLC, Canon City, Colorado, for making all the drawings even on a very short notice. Authors also thank Mr. Suresh Khosla and Mr. Pat Magilligan of A-1 Specialized Services and Supply, Inc., Croydon, Pennsylvania, for the encouragement and helpful hints in writing this paper.

REFERENCES

1. *Industrial Ventilation*, 18th ed. (American Conferences of Industrial Hygienists, 1984).
2. *Fan Engineering*, ed. R. Jorgenson (Buffalo, NY: Buffalo Forge Company, 1970).
3. *Air Pollution Engineering Manual*, ed. John A. danielson (USEPA, 1973).
4. *Link-Belt Catalogue #1000* (Link-Belt Company, 1967).
5. *Rock Talk Manual*, K1078, 2nd print (Kennedy Van Saun Corp., 1978).
6. G.W. Vinal, *Storage Batteries*, 4th ed. (John Wiley & Sons): 23-24.