



THE GRANITES GOLD MINE

North Flinders Mines Limited
(Incorporated in S.A.)

GOLD ROOM OPERATIONS MANUAL



Produced By
Michael Hand
(Senior Foreman)

July 1987

ACKNOWLEDGEMENTS

1. The development of the Intensive Cyanidation Procedure involved considerable test work. For the initial feasibility studies much is owed to Ian McGraffin, consultant metallurgist. The first full scale batch treatments were conducted by Ron Wilson, gold room foreman, in consultation with Keith Goble-Garrett, plant metallurgist. These trial treatments resulted in the setting down of operational procedures as detailed by Ron in section 6.4c of this manual.
2. The comprehensive coverage of the Wilfley table, Part 5.3, was written by Ron Wilson.
3. Rachel Chisholm very kindly prepared the cover for this manual.

M. H.

CONTENTS

| | <u>Page</u> |
|---|-------------|
| Acknowledgements. | i |
| List of Figures. | (iv) |
| Introduction. | (v) |
| PART I - THE STRIPPING SYSTEM. | |
| 1.1 General. | 1 |
| 1.2 Sequence Controllers. | 2 |
| 1.3 Description of Stripping Process. | 3 |
| 1.4 Electrowinning. | 5 |
| 1.5 Operation of the Stripping System. | 5 |
| 1.6 Fault Finding Procedure for the Stripping System. | 5 |
| PART 2 - THE SEQUENCE CONTROLLERS. | |
| 2.1 Acid Wash and Rinse Steps. | 8 |
| 2.2 Acid Wash and Rinse Instructions and Output Settings. | 9 |
| 2.3 Stripping Sequence Steps. | 10 |
| 2.4 Stripping Sequence Instructions and Output Settings. | 11 |
| PART 3 - OPERATION OF THE STRIPPING SYSTEM. (Step by Step Procedure) | |
| 3.1 General. | 12 |
| 3.2 Acid Wash. | 12 |
| 3.3 Washed Carbon Transfer. | 13 |
| 3.4 Reagent Addition and Pre-Treatment. | 13 |
| 3.5 Elution. | 15 |
| 3.6 Transfer of Barren Carbon to Regeneration Kiln Hopper. | 15 |
| 3.7 Electrowinning. | 17 |
| 3.8 Stripping System - Optimization of Reagent Usage. | 19 |
| PART 4 - THE STRIPPING SYSTEM - FAULT FINDING. | |
| 4.1 Acid Wash. | 21 |
| 4.2 Transfer of Loaded Carbon to Elution Column. | 21 |
| 4.3 Reagent Addition and Pretreatment Stage. | 22 |
| 4.4 Elution and Carbon Cool. | 23 |
| 4.5 Transfer of Barren Carbon to Regeneration Kiln Hopper. | 23 |
| PART 5 - THE GRAVITY CIRCUIT. | |
| 5.1 General. | 25 |
| 5.2 The Spirals. | |
| a. Optimum Operating Conditions. | 25 |
| b. The Static Distributor. | 26 |
| c. The Primary Spiral. | 26 |
| d. The Cleaner Spiral. | 28 |
| e. Maintenance of the Spirals. | 28 |

| | |
|--|----|
| PART 5 - THE GRAVITY CIRCUIT. (Continued) | |
| 5.3 The Wilfley Table. | |
| a. General Description. | 28 |
| b. The Head Motion. | 29 |
| c. Adjustment of Deck. | 30 |
| d. Action of Table. | 31 |
| e. Operation of Table. | 31 |
| f. Maintenance of Wilfley Table. | 32 |
| 5.4 Starting Up and Shutdown Procedure for the Gravity Circuit. | 33 |
| PART 6 - PREPARING OF GRAVITY CONCENTRATES FOR SMELTING. | |
| 6.1 General. | 34 |
| 6.2 Amalgamation. | 34 |
| 6.3 Acid Digestion. | 34 |
| 6.4 Intensive Cyanidation. | |
| a. General. | 37 |
| b. Description of Plant. | 37 |
| c. Operation of Plant. | 38 |
| d. Further Considerations. | 40 |
| PART 7 - PREPARING CATHODE WOOL FOR SMELTING. | |
| 7.1 General. | 42 |
| 7.3 Removing the Wool. | 42 |
| 7.3 Acid Digestion of Wool. | 42 |
| 7.4 Drying the Cake. | 43 |
| PART 8 - SMELTING. | |
| 8.1 The Furnace. | 45 |
| 8.2 Crucibles Used. | 46 |
| 8.3 Moulds Used. | 46 |
| 8.4 Fluxes Used. | 46 |
| 8.5 Smelting Procedure. | 47 |
| 8.6 Points to Watch. | 48 |
| PART 9 - CARBON REACTIVATION. | |
| 9.1 General. | 49 |
| 9.2 Start Up Procedure. | 51 |
| 9.3 L.E.D. Readouts. | 51 |
| 9.4 Shutting Down the Kiln. | 53 |
| 9.5 Adjustment of Rate of Carbon Discharge. | 53 |
| 9.6 Adjustment of Vibrator Intensity. | 53 |
| 9.7 Points to Watch. | 54 |
| PART 10 - GOLD ROOM GENERAL. | |
| 10.1 Other Gold Room Duties. | 55 |
| 10.2 Security. | 55 |
| 10.3 Safety. | 57 |
| 10.4 Reagents - Their Effects on Human Beings, First Aid Requirements, Handling and Disposal. | 59 |
| REFERENCES | 68 |

LIST OF FIGURES

| <u>Fig.</u> | | <u>Page</u> |
|-------------|--|-------------|
| 1. | Flow Diagram of the Stripping System. | 4 |
| 2. | Control Panel for the Stripping System. | 6 |
| 3. | Carbon Fill Selector. | 12 |
| 4. | Mill/Gravity Circuit Flow Diagram. | 24 |
| 5. | The Gravity Splitter Box. | 25 |
| 6. | The Static Distributor. | 26 |
| 7. | The Spiral Discharge Splitters. | 27 |
| 8. | The Wilfley Table. | 28 |
| 9. | The Wilfley Table Head Motion. | 29 |
| 10. | The Wilfley Table Stroke Pattern. | 29 |
| 11. | The Wilfley Table Rocker Pockets. | 30 |
| 12. | The Wilfley Table Tilting Mechanism. | 30 |
| 13. | The Wilfley Table - Inverse Classification and Stratification. | 31 |
| 14. | The Wilfley Table - Lines of Separation. | 32 |
| 15. | The Wilfley Table - Concentrate Launder and Splitter. | 32 |
| 16. | The Intensive Cyanidation Pilot Plant. | 36 |
| 17. | The Decant Platform. | 42 |
| 18. | The Barring Furnace. | 45 |
| 19. | The Carbon Reactivation Kiln. | 50 |
| 20. | The Carbon Reactivation Kiln Control Panel. | 52 |

INTRODUCTION

The Carbon-in-Pulp technique as practiced at The Granites was initially introduced into the gold processing industry so as to by-pass the counter current decantation and filtration steps of the Merrill-Crowe cyanidation-zinc cementation procedure.

Early development was hampered by a lack of suitable carbon offering good activity, mechanical strength and satisfactory price.

With the gold price rise of the seventies, the C.I.P. process has developed rapidly and there has been a rapid growth in the number of C.I.P. plants along with an equally rapid growth in technology and innovations in plant practice.

It is now generally accepted that the C.I.P. procedure offers substantial savings in both capital and operating costs over the Merrill-Crowe procedure at low head grades (<15g Au/tonne). The C.I.P. procedure has in fact made ore reserves with head grades of <5g Au/tonne commercially viable and many of the more recent developments are based on such reserves.

At The Granites head grades of >10g Au/tonne are commonplace and the nature of the feed is such that this plant would be hard-pressed to achieve good recovery, without a substantial drop in the rate of production, but for the improved efficiency of the gravity circuit.

It has been possible to reduce the number of strips each week and this has led to substantial savings in the use of reagents, gas and potable water.

Success in the production of gravity concentrates has prompted investigation into alternative methods of treating concentrates for smelting so that the present practice of Acid Digestion, along with its inherent dangers and operator discomforts, may be dispensed with.

Current experiments with Intensive Cyanidation have met with considerable success and if problems relating to the subsequent extraction of gold from the loaded Intensive Cyanidation product are overcome, this method could well supersede Acid Digestion.

This manual has been compiled in an attempt to familiarize all gold plant personnel with gold room operations and developments and in particular, to give C.I.P. plant operators and maintenance personnel, a better understanding of the areas of gold room operations in which they are directly associated.

M. H.

PART 1 - THE STRIPPING SYSTEM

1.1 General

The Anglo American Research Laboratories (AARL) stripping system used at The Granites has two definite advantages when compared with its most common counterpart, the Zadra system. It is much less expensive to operate and it produces a cleaner stripped carbon. It is however very reliant upon the availability of an abundant supply of good quality water and its water usage is far greater than that of either the Zadra system or the more recently developed solvent stripping system.

The stripping of gold from loaded carbon here involves two basic steps; Acid Washing and Elution. The elution step may be further divided into two major stages; carbon preheat and elution proper.

At The Granites a separate column is provided for acid washing. The advantages of this are dubious in that there would be more than enough time in a twenty four hour period for both steps to be completed in one column. In any case the potable water system here does not cater for the running of both steps at the same time. Much greater benefit would have been derived from the provision of an additional eluate tank as it is in the later electrowinning stage that most of the present hold ups occur.

a. Acid Washing

This involves the soaking of the loaded carbon in a 3% HCL solution in order to remove impurities such as calcium, copper and magnesium which can impede both the elution step and the later adsorption of gold onto the carbon after it has been returned to the C.I.P. circuit. Acid washing of carbon is in fact used as a temporary substitute for thermal reactivation of carbon in some plants.

b. Preheat Stage

During this stage a 2% caustic/3% cyanide solution mixture is re-circulated through the loaded carbon in the elution column until such time as a predetermined 'top of column' temperature is reached. By this time most of the gold and silver on the carbon will have been desorbed into solution and both the carbon and the solution will have reached an optimum temperature for the subsequent elution proper.

c. Elution stage

During this stage the gold and silver desorbed off the carbon during the preheat is washed out of the column into the eluate tank. This stage takes 2 1/2 hours and involves the use of 5 bed volumes of potable water (21.6 cubic metres). The critical factor during this stage is temperature. It has been found that the optimum 'top of column' temperature is around 110°C

1.2 Sequence Controllers

The goldroom uses the Anglo-American Research Laboratories stripping system to strip gold from loaded carbon in batches of approximately 1.9 tonnes. The process is fully automated and controlled by electronic sequence controllers which switch both pumps and valves for each step.

The controllers can be over-ridden to stop or reset a cycle or to start again, at any point. It should be remembered that no feedback to the controllers is provided and hence a signal for a pump to run or a valve to open does not necessarily mean that the item is operating. This can be confirmed by visual inspection at the pump or valve. Likewise it should be remembered that the controllers will not operate if a local stop switch is depressed. (See fig. 2 on page 6)



Although the sequence controllers govern the various stripping stages it is essential to monitor the plant on a regular basis so as to ensure that all equipment is operating properly and that desired temperatures are being reached and maintained within the time limitations set on the controllers. Here goldroom foreman, Ron Wilson, checks the panel prior to start up.

1.3 Description of the Stripping Process (See fig. 1)

a. Acid Wash

Carbon is loaded into the acid wash column from the loaded carbon surge hopper by opening the main inlet valve AV 401. Excess water and air are bled off through a screen and valve AV 414 to either the leach area sump or the tailings hopper. After filling, the main valve AV 401 is closed and dilute hydrochloric acid is injected into the bottom of the column via valve AV 403. Displaced water flows out of the top of the column through valve AV 414 to the tailings hopper. After acid injection and soaking, water is pumped into the bottom of the column via valve AV 404 and as it rises through the column to exit via valve AV 414, it rinses out the acid.

b. Transfer to Elution Column

After rinsing the carbon is pressure transferred to the elution column. Water is injected into the acid wash column via valve AV 404 to maintain pressure within the column and force the loaded carbon out through valve AV 406 into the carbon transfer line. Additional water is forced into this line via valve AV 402 and the carbon is forced along the line through valve AV 422 into the elution column. Displaced water flows out of that column through the inline filter, via valve AV 415 into the potable water tank.

c. Reagent Addition and Preheat:

The start of the stripping cycle involves the addition of NaCN (2 to 3%) and NaOH (2%) to the column via valve AV 410. Displaced water flows out of the top of the column through the inline filter, along the pregnant solution line to the heat exchanger to exit via valve AV 416 into the eluate tank.

After reagent addition, valve AV 416 closes and the elution water pump recirculates the solution in the column by pumping it via the heat exchanger and valve AV 409 up through the column and out through valve AV 460 back to the water pump. Heat is transferred to this solution as it passes through the heat exchanger from thermocal which is being recirculated through a heater and the heat exchanger. The preheat stage continues for a preset time, at the end of which the desired 'top of the column' temperature should be attained. By this time most of the gold will have been liberated from the carbon back into solution form. The thermocal heater and pump continue to operate throughout the preheat and subsequent elution stage so as to maintain desired operating temperatures.

d. Elution and Carbon Cool

During the elution cycle, water is drawn from the potable water tank and pumped through the heat exchanger via valve AV 409 into the column. The water then flows up through the column, taking with it gold that has been freed into solution during the preheat stage. This pregnant solution then flows out of the column through the inline filter and the heat exchanger, then via valve AV 416 to the eluate

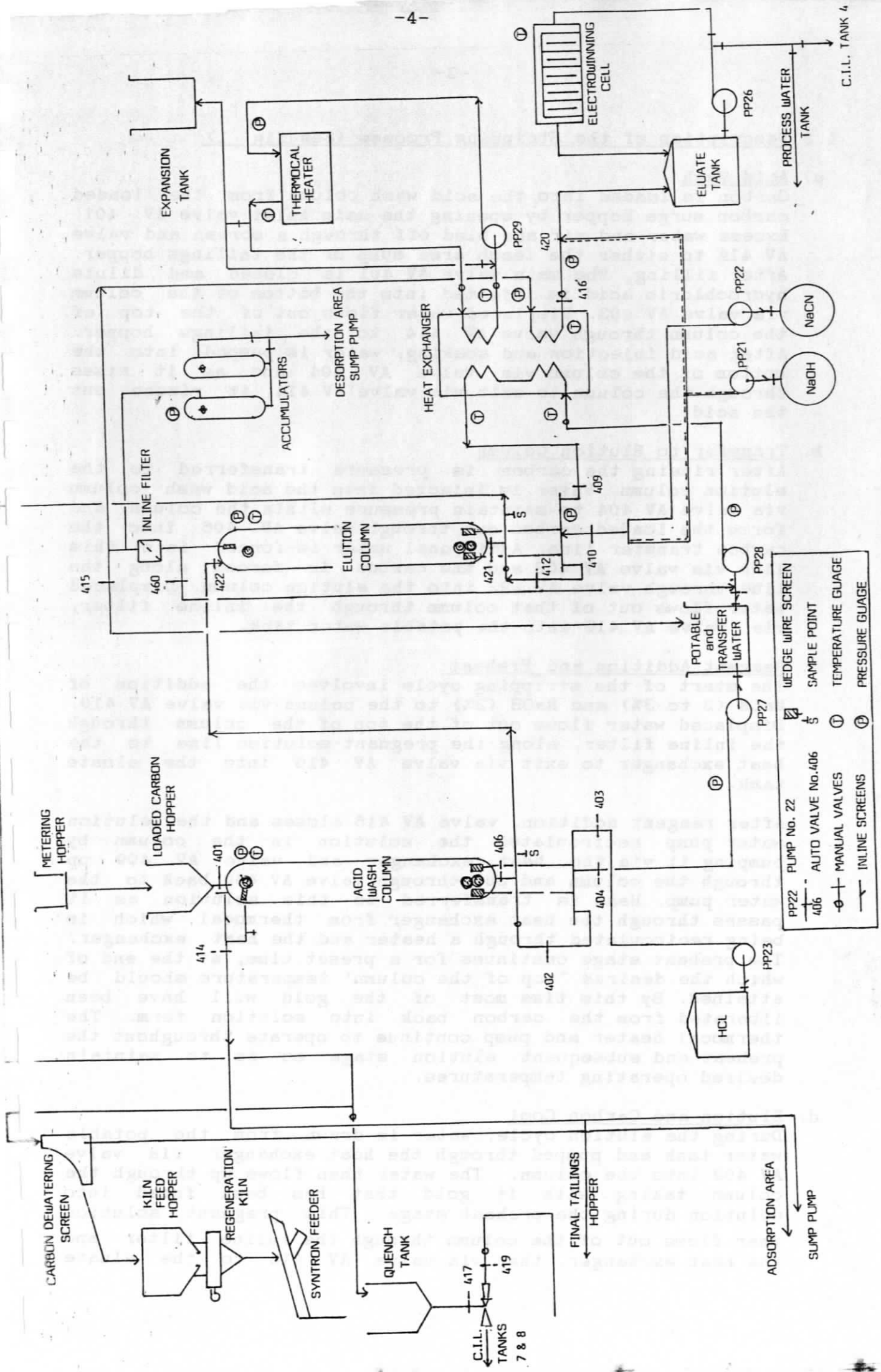

Fig. 1 Flow Diagram of the Stripping System

C.I.L. TANK 4

tank. This stage continues until five bed volumes of water have passed through the column (2.5 hours) after which desired barren carbon assays of -30g Au/tonne should be achieved.

At the end of the elution stage the thermocal heater stops and an additional amount of NaOH is pumped into the eluate tank via valve AV 420, this bringing the pH of the eluate solution up to the desired level. Potable water then continues to flow through the system as per the elution stage for another twenty minutes, this taking some of the heat out of the carbon and the thermocal. The thermocal pump operates for another two hours after the end of the carbon cool stage, this aiding the cooling down of the heater.

e. Transfer of Barren Carbon to the Regeneration Kiln Hopper

At the end of the carbon cool stage, water is pumped into the column via valve AV 409 so as to maintain pressure within it and force the barren carbon out of the column via valve AV 421 into the carbon transfer line. Additional water is injected into this line via valve AV 412 and the carbon is carried long the line to the dewatering screen above the regeneration kiln feed hopper.

1.4 Electrowinning

One bed volume (thirty minutes) into the elution stage the eluate pump is started and pregnant solution from the eluate tank is pumped up into the electrowinning cell on the first floor of the goldroom. It then flows back into the eluate tank. As the solution flows through the electrowinning cell, gold is plated on to the steel wool cathodes. This recirculation process continues for around 14 to 16 hours after which period of time there should be no more than -1g Au/tonne of eluate remaining in solution. The barren solution is then pumped out of the eluate tank into the process water tank.

1.5 Operation of the Stripping System

Details of the step by step sequence controller operation for the entire stripping process are outlined in part 2. This information is displayed on the control cubicle. The mere following of the instructions given in that section will not ensure effective stripping results as there are many extraneous factors which need to be taken into account. Part 3 outlines in full detail every action required on the part of goldroom personnel in order to operate the plant successfully. Operators unfamiliar with The Granites stripping system should follow Part 3 directly. Loose copies are available. "Operation of the Stripping System - Step by Step Procedure".

1.6 Fault Finding Procedure for the Stripping System

Should any difficulties occur during the stripping process, possible faults with remedial action have been detailed in part 4 of this manual.

Sequence complete

All drives stop

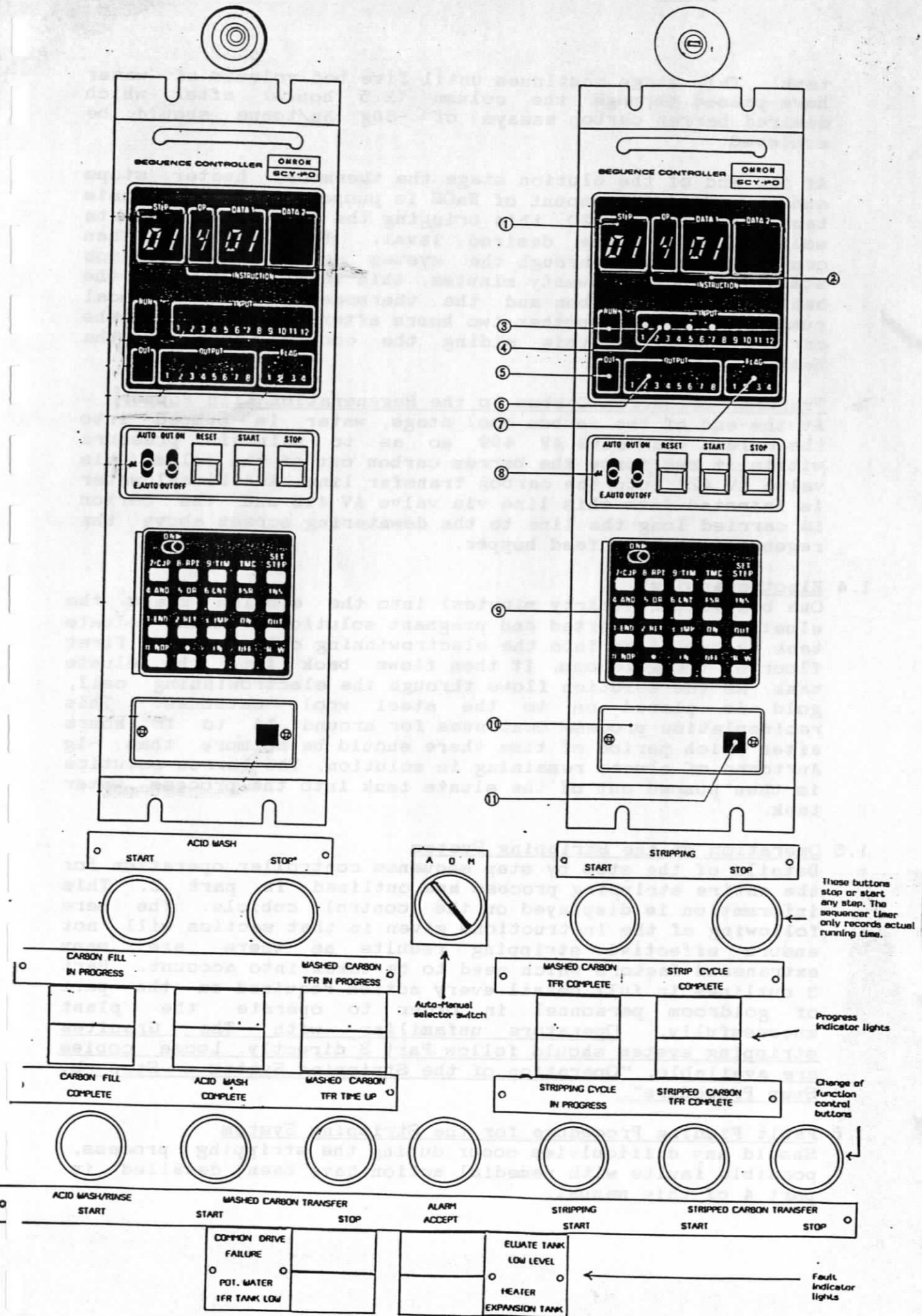

Fig. 2 Control Panel for the Stripping System

- 1 STEP ... Step display
- 2 INSTRUCTION ... Instruction display. The STEP display indicates the step number (or process) in progress, and the INSTRUCTION display consisting of OP, DATA-1 and DATA-2 displays indicates the step advance conditions. These displays are used for monitoring the keyboard programming, as well as monitoring the program being executed.
- 3 RUN ... Run display (LED) The LED indicator lights when the START switch is depressed in the manual or automatic mode and goes off when the STOP switch is depressed.
- 4 INPUT ... Input display (LED) For indication of input status.
- 5 OUT ... Output operation display (LED) The LED indicator lights when the output is not prohibited
- 6 OUTPUT ... Output display (LED) For indication of output status. The LED indicator also illuminates when the OUT ON/OUT OFF selector switch is set in the "OUT OFF" position.
- 7 FLAG ... Flag display (LED) For indication of flag status. The LED indicator also illuminates when the OUT ON/OUT OFF selector switch is set in the "OUT OFF" position.
- 8 Operation switches:
 - AUTO/M/E.AUTO selector switch
 - AUTO .. Automatic operation mode selection.
 - M .. Manual operation mode selection
 - E.AUTO .. Automatic or manual mode selection by external signal.
 - OUT ON/OUT OFF selector switch .. In the OUT OFF position, outputs (including flag outputs) are prohibited. The OUT ON position allows outputs to be generated.
 - RESET switch .. Depressing this switch causes the program to reset to step 01 and places the controller in STOP state.
 - START switch .. Depressing this switch places the controller in RUN state, causing automatic or manual operation to start.
 - STOP switch .. Depressing this switch places the controller in STOP state causing the current step to be held.
- 9 Program Console Keyboard switches for programming. Program console switch must be turned on when programming.
- 10 Battery Lid Battery, unit number setting switch for parallel processing and program protect switch are mounted inside.
- 11 Unit Number Setting Switch.

Sequence Controller Operations

PART 2 - THE SEQUENCE CONTROLLERS

2.1 Acid Wash and Rinse Steps

| <u>Job</u> | <u>Refer Step</u> | <u>Action</u> |
|------------|-------------------|--|
| 1. | 01 | Press <i>SEQUENCE START</i> . "Run" and "Output" lights show. Manually initiate sequence by switching the Carbon Fill Selector switch to "Fill" and then "Complete" after the column has filled with carbon. |
| 2. | 03 | Press <i>ACID WASH RINSE START</i> . This adds concentrated HCL and water to the column. |
| | 04 | Allows soak in acid. |
| | 05 | Rinses carbon column with water to remove acid and restore neutral pH to the solution |
| 3. | | On completion of the water rinse step, the alarm will sound. Press <i>ALARM ACCEPT</i> . |
| 4. | 10 | Press <i>WASHED CARBON TRANSFER START</i> to commence the transfer of carbon to the elution column. |
| 5. | | On completion of transfer the alarm will sound. Press <i>ALARM ACCEPT</i> and then shut down by pressing <i>WASHED CARBON TRANSFER STOP</i> |
| | | Sequence is ended. |

Note:

- (1) During the carbon transfer take *LOADED CARBON* samples from the sample point on the transfer line.
- (2) Complete log sheet by recording times and volumes of water used during this sequence.
- (3) The programme can be interrupted at any stage by pressing *SEQUENCE STOP*. It can be resumed by pressing *SEQUENCE START*. The cycle will then start again from the point at which it was interrupted.

2.2 Acid Wash and Rinse Instructions and Output Settings

| INSTRUCTIONS | | | | OUTPUT SETTINGS | | | | | | | | | | |
|--------------|-----|--------|--------|--|-------|-------|-------|------------------------|--------------------|---------------|-------|--------------------|-------------------|-----------|
| | | | | SV401 | SV402 | SV403 | SV404 | SV406,415,422; PP27 FF | PP27 HF Water Pump | PP23 HCL Pump | SV414 | Acid Wash Complete | End Transfer Time | Cycle End |
| STEP NO. | OP. | DATA 1 | DATA 2 | 1 | 2 | 3 | 4 | 5 | 6 | 7 | 8 | 9 | 10 | 11 |
| 00 | | | | | | | | | | | | | | |
| 01 | 4 | 01 | 00 | | | | | | | | | | | |
| 02 | 4 | 02 | 00 | X | | | | | | | | | | |
| 03 | 9 | 08 | 00 | | | X | X | | X | X | | | | |
| 04 | 9 | 10 | 00 | | | | | | | | | | | |
| 05 | 9 | 2 | 00 | | | | X | | X | X | | | | |
| 06 | 0 | 71 | 00 | | | | X | | X | | | | | |
| 07 | 4 | 03 | 00 | | | | | | | | | X | X | |
| 08 | 9 | 00 | 01 | | | | | | | | | X | X | |
| 09 | 0 | 71 | 00 | | | | | | | | | X | | |
| 10 | 9 | 30 | 00 | | X | | X | X | | | X | | | |
| 11 | 0 | 72 | 00 | | X | | X | X | | | X | | | |
| 12 | 4 | 04 | 00 | | X | | X | X | | | X | | X | |
| 13 | 0 | 73 | 00 | | X | | X | X | | | X | | X | |
| 14 | 9 | 00 | 01 | | | | X | X | | | | | X | X |
| 15 | 0 | 72 | 00 | | | | | | | | | | X | X |
| 16 | 0 | 73 | 00 | | | | | | | | | | X | X |
| 17 | 1 | 01 | 00 | | | | | | | | | | | X |
| 18 | | | | | | | | | | | | | | |
| CODE | | | | ACTIVITY | | | | | | | | | | |
| 4 | | | | Instructs the programme to proceed to the next step. | | | | | | | | | | |
| 9 | | | | The programme carries out the instructions shown by the output setting for the time shown in Data 1 and Data 2. Times may be varied. | | | | | | | | | | |
| 1 | | | | This causes the programme to reset to Step 01 | | | | | | | | | | |
| 2 | | | | The programme advances to the next step. | | | | | | | | | | |

2.3 Stripping sequence steps

| <u>Job</u> | <u>Refer Step</u> | <u>Action</u> |
|--------------------|-------------------|---|
| 1. | 01 | Press <i>SEQUENCE START</i> . The "Run" and "Output" lights will show on the panel. |
| 2. | 02 | Press <i>STRIPPING CYCLE START</i> . Cyanide and caustic are added to the elution column to soak the bed of carbon. |
| | 05 | In this cycle the strong cyanide and caustic solution is circulated. The temperature is raised from ambient to 90°C. |
| | 06 | The stripping stage is done by continuously pumping water at about 110°C through the bed of carbon in the elution column. The pregnant solution or eluate, flows into the eluate tank. |
| | 07 | An addition of caustic is made to the eluate. |
| | 09 | The cool rinse stage. The burner shuts off (The thermocal pump will continue to run for two hours) and cool water is pumped through the elution column. |
| 3. | | On completion of the stripping cycle, the alarm will sound. Press <i>ALARM ACCEPT</i> . |
| 4. | 13 | Press <i>STRIPPED CARBON TRANSFER START</i> to commence transfer of carbon to the regeneration kiln feed hopper. |
| 5. | | The alarm will sound at the end of the designated transfer time. Press <i>ALARM ACCEPT</i> . The transfer pump will still be operating. If all of the carbon has been transferred (check sight glass) stop by pressing <i>STRIPPED CARBON TRANSFER STOP</i> |
| Sequence is ended. | | |

Note

1. During the carbon transfer take *STRIPPED CARBON* samples from the sample point on the transfer line.
2. The electrowinning cell may be started after one bed volume has passed through the column in step 6.
3. Fill in the relevant information on the log sheet.
4. To stop programme at any stage press *SEQUENCE STOP*
Resume programme by pressing *SEQUENCE START*

2.4 Stripping Sequence Instructions and Output Settings

| INSTRUCTIONS | | | | OUTPUT SETTINGS | | | | | | | | | | | |
|--------------|--|--------|--------|-----------------|------------------------|------------------------|-------|-------|-------------------|-------|--------------------|-------------|---------------------|--------------------------|--------------------------|
| | | | | SV409 | SV410, PP22 Cyanide P. | SV412, 421 and PP28 FF | SV416 | SV420 | PP21 Caustic Pump | SV460 | PP28 HF Water Pump | HE 1 Heater | PP29 Thermocal Pump | Stripping cycle complete | Stripped Carbon Transfer |
| STEP NO. | OP. | DATA 1 | DATA 2 | 1 | 2 | 3 | 4 | 5 | 6 | 7 | 8 | 9 | 10 | 11 | 12 |
| 00 | | | | | | | | | | | | | | | |
| 01 | 4 | 01 | 00 | | | | | | | | | | | | |
| 02 | 9 | 10 | 20 | | X | | X | | X | | | | | | |
| 03 | 0 | 72 | 00 | | X | | X | | X | | | | | | |
| 04 | 0 | 71 | 00 | | X | | X | | X | | | | X | | |
| 05 | 9 | 50 | 00 | X | | | | | | X | | X | X | | |
| 06 | 9 | 2 | 30 | X | | | X | | | | X | X | X | | |
| 07 | 9 | 8 | 00 | X | | | X | X | | | X | X | X | | |
| 08 | 0 | 71 | 00 | X | | | X | X | X | | X | X | X | | |
| 09 | 9 | 30 | 00 | X | | | X | | | | X | X | X | | |
| 10 | 0 | 73 | 00 | X | | | X | | | | X | | X | | |
| 11 | 4 | 02 | 00 | | | | | | | | | | X | X | |
| 12 | 0 | 73 | 00 | | | | | | | | | | X | X | |
| 13 | 9 | 20 | 00 | X | | X | | | | | | | X | | |
| 14 | 0 | 74 | 00 | X | | X | | | | | | | X | | |
| 15 | 4 | 03 | 00 | X | | X | | | | | | | X | | X |
| 16 | 9 | 00 | 01 | | | | | | | | | | X | | X |
| 17 | 0 | 72 | 00 | | | | | | | | | | X | | X |
| 18 | 0 | 74 | 00 | | | | | | | | | | | | X |
| 19 | 1 | 01 | 00 | | | | | | | | | | | | |
| CODE | ACTIVITY | | | | | | | | | | | | | | |
| 9 | The programme carries out the instructions shown by the output setting for the time shown in Data 1 and Data 2. Times may be varied. | | | | | | | | | | | | | | |
| 4 | Instructs the programme to proceed to the next step. | | | | | | | | | | | | | | |
| 1 | This causes the programme to reset to Step 01 | | | | | | | | | | | | | | |
| 0 | The programme advances to the next step. | | | | | | | | | | | | | | |

PART 3 - OPERATION OF THE STRIPPING SYSTEM
(Step by Step Procedure)

3.1 General

- a. Check the electrowinning cell and take a sample over to the laboratory. Label the sample:-

"E/W No. _____ DATE _____ TIME _____ TAIL"

- b. Check the potable water meter reading and the available potable water (off tank level indicator); and the gas pressure. Note these on the log sheet for the preceding day.

3.2 Acid Wash

- a. After ensuring that there is sufficient carbon in the loaded carbon surge hopper, switch the valve control switch (See fig. 3) to 'auto' to open the valve.



Fig. 3 Carbon Fill Selector

Then put a running hose in the hopper and wait for the acid wash column to fill with carbon. When the carbon is visible in the top sight glass switch the control switch back to 'manual' to close the valve. Check to ensure that the inline trash screen is clear.

- b. Make sure that the manual valve on the acid container is open. Record the time, the level of acid in the container and the reading for potable water off the meter by the potable water tank, on the goldroom log sheet. Press the 'acid wash/rinse start' button on the main control panel.
- c. Check to see that the acid pump is running. As soon as it stops check and note on the log sheet, the acid level in the container. Also close the manual valve on the container.
- d. The sequence controller will automatically take the sequence through the soak step (04) and the rinse step (05). At the end of step 5 the alarm will sound. Check the pH level of the solution from the sample point at the top

of the column. If it is over 5 press the 'alarm accept' button.

3.3 Washed Carbon Transfer

- a. Press the 'washed carbon transfer start' button on the control panel. Whilst the carbon is being transferred take samples from the transfer line sample point, every five minutes. Rinse the combined sample and label it:-

"STRIP No. _____ DATE _____ LOADED Au content"

- b. Towards the end of the carbon transfer step the alarm will sound. Press the 'alarm accept' button but do Not press the 'washed carbon transfer stop' button until the acid wash column is seen to be empty by way of both the bottom of column sight glass and the absence of carbon in the transfer water at the sample point.
- c. After the transfer is completed and you have pressed the 'washed carbon transfer stop' button, drain out the accumulator vessels by way of the two ball valves near the right hand side vessel and then clean out the filter bag at the top of the elution column. Make sure that the filter bag has no holes in it and that the pliable band fits snugly into the ledge inside the filter housing. Also ensure that the steel ball has been put back inside the bag.
- d. Close the accumulator drain valves and also the manual back up valve on the barren carbon transfer line.

3.4 Reagent Addition and Preheat

- a. On the log sheet, note the meter readings for the caustic, and cyanide pumps and also that of the potable water supply.
- b. On the elution control panel press the 'sequence start' button and then the 'stripping cycle start' button. This step will not commence if the eluate tank 'low level' light is not on, i.e. the tank has not been pumped out or the low level indicator is faulty.
- c. During the addition of reagents step (02) visually check that the pumps are operating and also record the meter readings immediately after the pumps stop. Should the output of either pump be drastically short of the desired amount (Presently 565 litres of cyanide and 100 litres of caustic) immediately press one of the pump stop switches and then reset it, This action will prevent the sequence controller from continuing on through the elution programme. It will then be necessary to add additional

reagent by the steps outlined below:-

- (i) Switch the controller to 'manual' by way of the black selector switch on the main control panel
 - (ii) Open auto valves AV 410 and AV 416 manually.
 - (iii) Start the desired reagent pump locally and run it until the desired additional litres have been added as per meter.
 - (iv) Reset the pump stop switch.
 - (v) Close auto valves AV 410 and AV 416 manually.
 - (vi) Switch the controller back to 'auto'.
 - (vii) Press the 'sequence start' button on the control panel. The controller will automatically continue on with the preheat cycle (step 05).
- d. Check to ensure that the thermocal heater is operating. If it fails to start it is most likely to be because the thermocal pressure is too low as a result of an airlock in the heater circuit. Correct this by opening the ball valve above the 'thermocal in' line for thirty seconds or so. If some time has elapsed before it was noticed that the heater was not going, the preheat step (05) should be restarted by the following method:-
- (i) On the sequence control panel, switch the left hand side toggle switch from 'auto' to 'm' and the adjacent toggle switch from 'out' to 'out off'.
 - (ii) Press the white 'reset' button next to the toggle switches.
 - (iii) By pressing the blue 'start' button step the controller through to step 05 again.
 - (iv) Put the toggle switches back to 'auto' and 'out on' respectively. The preheat step will then automatically commence again and run for the full set time.
- e. Monitor the preheat step regularly and record both temperatures and pressures on the log sheet every half hour. the desired top of column temperature at the end of the preheat step varies with weather conditions, but during the cooler months it should reach 90° approximately. If this temperature is not reached then the preheat step will need to be extended by switching the left hand side toggle switch to 'm'. The preheat step will then over-ride the timer and continue on until the toggle switch is put back to auto.

- f. Should the column pressure rise rapidly during preheat to above 400 kPa, it may be necessary to stop the cycle. Either stop the elution pump locally or press the red 'sequence stop' button on the control panel. Then drain the accumulator vessels until the top of column pressure falls below 150 kPa. Restart by resetting the pump stop switch and pressing the 'sequence start' button on the control panel.

3.5 Elution

- a. After preheat the controller will automatically go into the elution step (06). Monitor this step regularly and record temperatures and pressures every thirty minutes.
- b. Start the electrowinning cell after the first bed volume - thirty minutes running time.
- c. After one hour in the elution step (06) the following operating parameters are considered desirable.

| | |
|------------------------------------|----------------|
| Top of column temperature | around 110°C |
| " " pressure | around 130 kPa |
| Bottom of column temperature | around 125°C |
| " " pressure | around 300 kPa |
| Elution water pump pressure | 270 to 300 kPa |
| Heat exchanger pressure in | 170 to 190 kPa |
| " " pressure out | 150 to 170 kPa |
| Thermocal temperature in | around 125°C |
| " " out | around 122°C |

A falling top of column temperature is the best indicator of possible trouble caused by such things as dirty heat exchanger plates, thermocal heater not operating properly or pegged inline screens.

3.6 Transfer of Barren Carbon to Regeneration Kiln Hopper

- a. Open the back up manual valve on the barren carbon transfer line.
- b. Back flush the carbon transfer line into the quench tank by attaching a hose to the minsup coupling behind the dewatering screen above the feed hopper. This step is only necessary if the previous lot of barren carbon was transferred directly into the quench tank.
- c. Close the carbon delivery valve above the quench tank.

- d. Make sure that the dewatering screen is clean.
- e. Fill the carbon transfer line by putting a hose on the sample point and running it until an adequate flow of return water is evident. Do not over flush as this could flood the kiln.
- f. Press the 'stripped carbon transfer start' button and throughout the transfer monitor:-
 - (i) The flow of return water. Should this decrease markedly, stop the elution water pump locally and flush the carbon transfer line again. Restart the transfer by pressing the 'sequence start' button.
 - (ii) The bottom of column pressure. Should this rise suddenly above 220 kPa, immediately stop the elution water pump and repeat the procedure outlined in (i) above.
- g. Take regular samples throughout the transfer and label the combined sample:-

"STRIP No. ____ BARREN, DATE ____, activity and Au"
- h. The alarm will sound at the end of the programmed transfer time. Press the 'alarm accept' button and then check to see if the transfer is completed by:-
 - (i) Looking in the bottom sight glass.
 - (ii) Observing clear water only gushing from the sample point.
 - (iii) Noting a marked increase in the flow of return water. Wait for this before stopping the transfer by stopping the elution water pump locally. This is important as the increased flow indicates that the carbon transfer line is flushed clear. Again do not risk flooding the kiln by over flushing the line.
- i. After stopping the elution water pump locally, reset the switch and then reset the sequence controller by:-
 - (i) On the sequence controller panel, switch the L.H.S. toggle switch to 'm' and the adjacent toggle switch to 'out off'.
 - (ii) Pressing the white 'reset' button next to the toggle switches.
 - (iii) Pressing the blue 'start' button and then putting the toggle switches back to their original positions.

3.7 Electrowinning

a. General

One bed volume (thirty minutes) after the commencement of the elution step (06) the electrowinning cell may be put into operation. When a strip is not in progress and the cell is required to electrowin intensive cyanidation product, at least 15 cubic metres of hot water should be pumped from the column into the eluate tank beforehand.

b. Start Up Procedure

- (i) Check the valves by the eluate tank.
- (ii) Shut the drainage valve at the base of the cell.
- (iii) Open the input valve partly.
- (iv) Make sure that the fume exhaust fan is operating. This should be left on at all times.
- (v) Start the pump - it will not start if the local switch outside the goldroom door has been left isolated.
- (vi) Open fully the input valve.
- (vii) When there is a flow over the weir at the discharge end of the cell, switch on the rectifier and adjust the volts to no more than 5.0; the amps will be around 600.
- (viii) Regulate the input valve so that the eluate level is about half way up the overflow outlet of the cell.
- (ix) Monitor the cell regularly to check on both eluate level and volts.
- (x) Check the pH and cyanide levels. They should be around 12.5 and approximately 0.3% respectively.
- (xi) Tell the night shift personnel that the cell is operating. If there is a power failure, the pump will need to be restarted at the local switch.

c. Shut Down Procedure

- (i) Take an eluate sample. The assay should be <5 ppm./Au before shutdown and if there is time, <1 ppm./Au.
- (ii) Stop the pump - reset the switch immediately.
- (iii) Open the dump valve on the line leading to the eluate tank.
- (iv) When the cell is half empty, switch off the rectifier and turn the control knob back to zero.

- (v) Shut or open the appropriate valves by the eluate tank.
- (vi) Before pumping out the spent eluate to the process water tank, advise both the intensive cyanidation operator and the shift foreman.
- (vii) When the tank is pumped out, the eluate pump should stop and the low level indicator will come on on the control panel. Change the valves by the eluate tank back to the positions required for electrowinning.

d. Points to Watch

1. High eluate level in the cell could indicate:-
 - (i) The cathodes are blocked with slime or fully loaded.
 - (ii) The input valve is opened too far.
2. Low eluate level in the cell could indicate:-
 - (i) The pump is faulty.
 - (ii) The input valve is shut too far.
3. Incorrect voltage level could indicate:-
 - (i) Too much resistance in the cathodes, i.e. they are heavily loaded or slimed up.
 - (ii) Faulty electrical contact on the cell.
 - (iii) Incorrect pH level.
4. Eluate is poisonous - wear gloves when taking a sample or handling the cathodes. Do not linger by the cell even when the fume exhaust fan is operating.

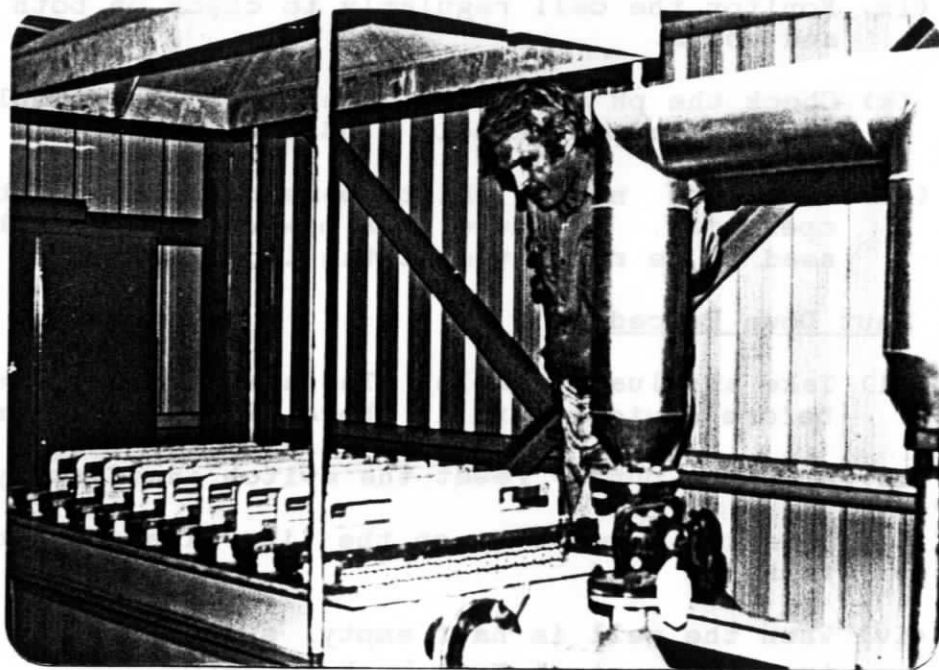

Two Mintek design cells are used here for recovery of gold by electrowinning from the eluate. Each cell has nine cathodes and these can together load up to 70 kgs. of gold plate on about 3.5 kgs. of steel wool under good conditions.

3.8 Stripping System - Optimization of Reagent Usage

a. Desired Reagent Levels

Acid Wash
 Step 03 2% HCL

Stripping sequence
 Step 02 2 to 3% NaCN

Electrowin sufficient NaOH for pH 12.5

b. Control of Reagent Addition

The reagent addition can be controlled by altering either the pump speeds, i.e. by changing the pulleys, and/or adjusting the dosing time that has been programmed into the sequence controller. Altering of the pump speed is preferable in cases where a change in the level of one reagent only is desired on a permanent basis. Changing of the dosing time in the stripping sequence (step 02) results in the changing of the levels of both NaCN and NaOH as the same timer controls both pumps. Should it be necessary for some reason to add an additional amount of either reagent at the end of step 02, e.g. in cases where the pressure relief valve of a particular pump is faulty and reagent goes back into the tank, this may be done by operating both the particular pump and the relevant valves manually. Refer to section 2.4c of this manual.

c. Example Calculation of Reagents Required for Stripping Sequence Step 02

NaCN added 560 litres @ 15%
 NaOH added 100 litres @ 49%

Volume of column .. 3900 litres

Bed volume
 (1.9 tonnes) 3600 litres
 of which 0.6 is occupied by aqueous phase.

Hence in the preheat step (05), available aqueous phase

$$\begin{aligned}
 &= (3900 - 3600 \text{ litres}) \text{ excess space in column.} \\
 &+ (0.60 \times 3600 \text{ litres}) \text{ aqueous phase in bed volume.} \\
 &+ \frac{100 \text{ litres}}{\text{in external pipework}} \\
 &= 2560 \text{ litres.}
 \end{aligned}$$

NaOH added to preheat

$$\begin{aligned}
 &= 100 \text{ litres} \times 1.5 \text{ (sg correction)} \\
 &= 150 \text{ kgs.}
 \end{aligned}$$

Since it is at 49%, the total NaOH added

$$= 150 \text{ kgs.} \times \frac{49}{100} = 73.5 \text{ kgs.}$$

Level of NaOH in column

$$= \frac{73.5}{2560.0} \times 100 = 2.9\%$$

NaCN added to preheat (no sg correction required)

$$= \frac{15.0}{100.0} \times 560 = 84.0 \text{ kgs.}$$

Level of NaCN in column

$$= \frac{84.0}{2560.0} \times 100 = 3.3\%$$

d. Determining Optimum Acid Wash Rinsing Time

The acid rinse step (05) is currently set for 2.5 hours. This could be excessive and wasting potable water. To determine the optimum time it is necessary to take samples every fifteen minutes from the rinse discharge line sampling point at the top of the acid wash column.

These samples should be analysed for Ca plus Mg and then the totals plotted versus time. When the curve flattens out, the rinsing is sufficient (even if the pH is only 4). The sequence controller time for step 06 should then be reset to the time indicated by the graph.

PART 4 - THE STRIPPING SYSTEM - FAULT FINDING

4.1 Acid Wash

| <u>Problem</u> | <u>Possible Cause</u> |
|--|--|
| a. Carbon does not enter column. | (i) Valve AV 401 not open. (ii) Valve AV 414 not open. (iii) Carbon hanging up - put more water in hopper. (iv) Blocked screen in top of column. |
| b. Acid wash will not start. | (i) Fill selector switch not on manual. |
| c. Column pressure over 200 kPa. | (i) Valve AV 414 not open. (ii) Blocked screen in top of column. |
| d. No discharge during acid injection or rinsing | (i) Pump pressure relief valve stuck open. (ii) Valve AV 404 not open. (iii) Feed valve to pump not open. (iv) Blocked inline screen before pump. (v) Water pump stator damaged. (vi) Acid pump faulty. |

Points to Watch

1. Clean the inline strainer at the top of the column regularly.
2. Watch the column pressure - if it exceeds 200 kPa the screen in the top of the column may need cleaning.
3. Check the discharge sump during acid injection and rinsing.
4. At the end of the rinse stage the discharge water should have a pH level of >5.

4.2 Transfer of Loaded Carbon to Elution Column

| <u>Problem</u> | <u>Possible Cause</u> |
|----------------------------------|---|
| a. High elution column pressure. | (i) Blocked inline filter bag. (ii) Valve AV 415 not open. (iii) Transfer line to potable water tank blocked. |

- b. High acid wash column pressure. (but not elution column pressure.)
 - (i) Carbon transfer valves AV 406 and/or AV 422 not open.
 - (ii) Carbon transfer pipe blocked.
- c. No water discharging to potable water tank.
 - (i) Valve AV 415 not open.
 - (ii) Water pump feed valve not open.
 - (iii) Water pump stator damaged.
 - (iv) Water pump not running.

Points to Watch

1. The filter bag at the top of the elution column should be cleaned out after each carbon transfer.
2. Make sure that the acid wash column is empty at the end of each transfer.
3. Watch the pump pressure - it should not exceed 350 kPa.
4. Watch for water discharge to the potable water tank - should start after the elution column fills with water.
5. Don't forget to take incremental samples from the carbon transfer line sample point.

4.3 Reagent Addition and Preheat Stage

| <u>Problem</u> | <u>Possible Cause</u> |
|--|--|
| a. High column pressure during reagent addition. | (i) Valve AV 416 not open. (ii) Blocked line to eluate tank. (iii) Inline filter bag dirty. |
| b. Reagent pump relief valve by-passing fluid. | (i) Blocked reagent line. (ii) Valve AV 410 not open. (iii) Pressure relief valve faulty. |
| c. Elution water pump cavitating. | (i) Blocked screens in bottom of column. (ii) Dirty heat exchanger plates. (iii) Airlock in top of column. |
| d. Heater stops. | (i) Elution water pump not running. (ii) Thermocal pump not running. (iii) Thermocal pressure low. |
| e. High column Pressure. | (i) Temperature at top of column too high. (Preheat temperature should not exceed 90°C) (ii) Heat exchanger plates dirty. |

Points to Watch

1. Whilst the reagent pumps are operating check that the pressure relief valves are not bypassing any fluid and that the flow meters are operating.
2. Check the bottom of column pressure - it should not exceed 350 kPa.
3. Watch the elution water pump pressure relief valve for any liquid discharge.
4. Make sure that no solution is leaking through the carbon transfer valve AV 421.

4.4 Elution and Carbon Cool

| <u>Problem</u> | <u>Possible Cause</u> |
|--|--|
| a. Stable elution temperature below 110°C from column. | (i) Heat exchanger plates dirty. (ii) Elution water pump flow rate too high. (iii) Preheat not brought up to desired column top temperature - 90°C). |
| b. Stable elution temperature over 115°C from column. | (i) Flow rate of water too low. (ii) Thermocal temperature too high. |

Points to watch

1. Maximum thermocal temperature should not exceed 125°C.
2. Throttling valve should be adjusted to maintain bottom of column pressure at 300 kPa during the elution.
3. The elution water pump flow rate should be between 110 and 120 l/min.

4.5 Transfer of Barren Carbon to Regeneration Kiln Hopper

| <u>Problem</u> | <u>Possible Cause</u> |
|--|--|
| a. High column pressure. | (i) Valve AV 421 not open. (ii) Blocked carbon transfer line. |
| b. No discharge to kiln dewatering screen. | (i) Valve AV 409 and/or AV 412 and /or AV 421 not open. (ii) Elution water pump feed valve not open or inline screen before it blocked. |

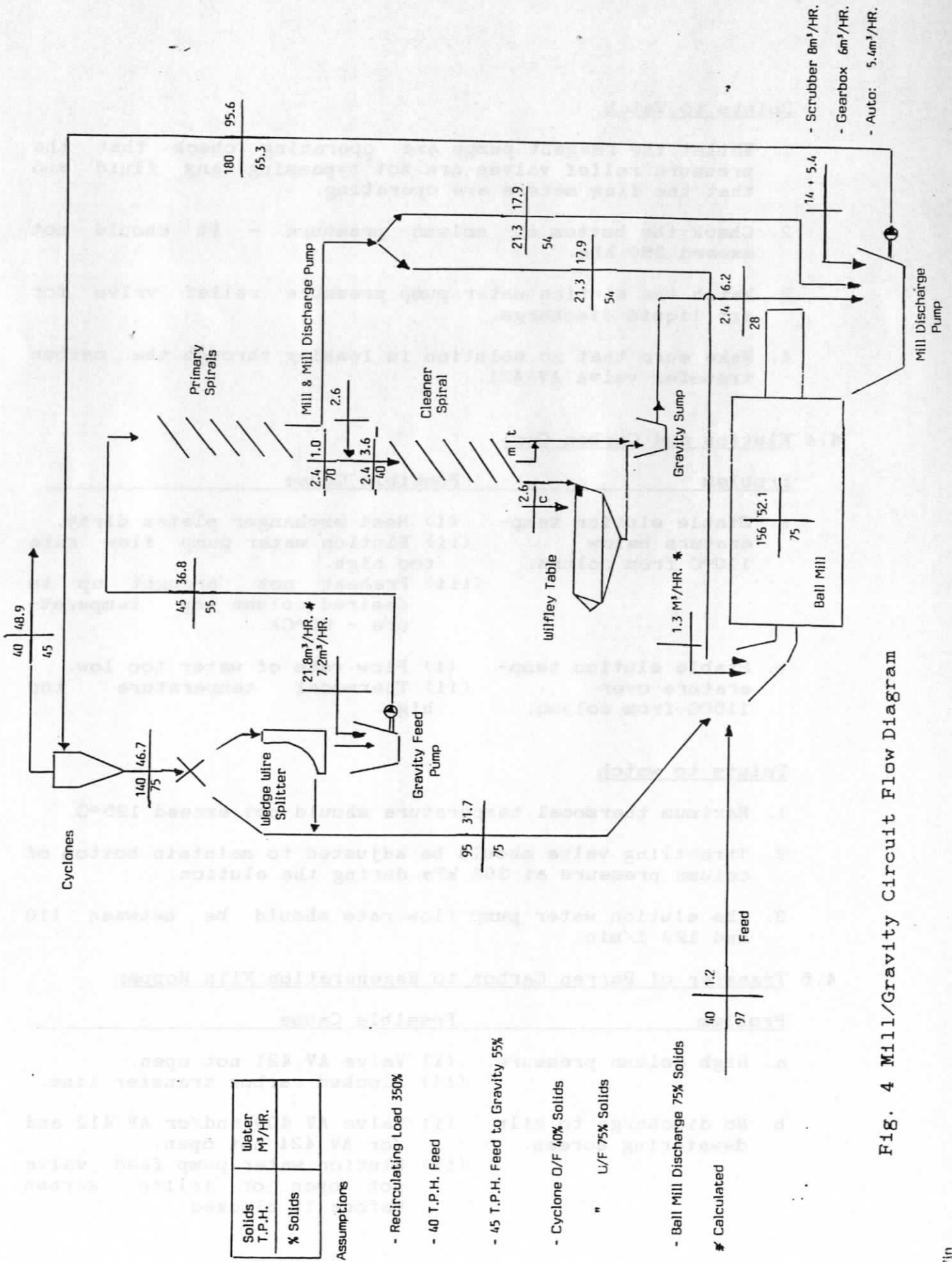

Fig. 4 Mill/Gravity Circuit Flow Diagram

PART 5 - THE GRAVITY CIRCUIT

5.1 General

The gravity circuit is designed to extract 'coarse gold' from the recirculating load in the mill grinding circuit and hence prevent a build up within that circuit and the eventual escape of some of that gold into the C.I.L. tanks and thereon into the final tails. (See fig. 4)

5.2 The Spirals

a. Optimum Operating Conditions

For the spirals to work efficiently the feed supply must have consistent characteristics and be of a constant rate. Variations in the flow rate, the feed size distribution and percentage solids will have adverse effects upon separation. Generally the solids tonnage should give adequate loading of the concentrate and middlings areas and the pulp density should be low enough to ensure mobility of particles in these areas.

Feed to the spirals may be adjusted by the moving of two splitter arms on either side of the cyclone underflow discharge box, this altering the volume of the feed passing over the splitter screen. (See fig. 5)

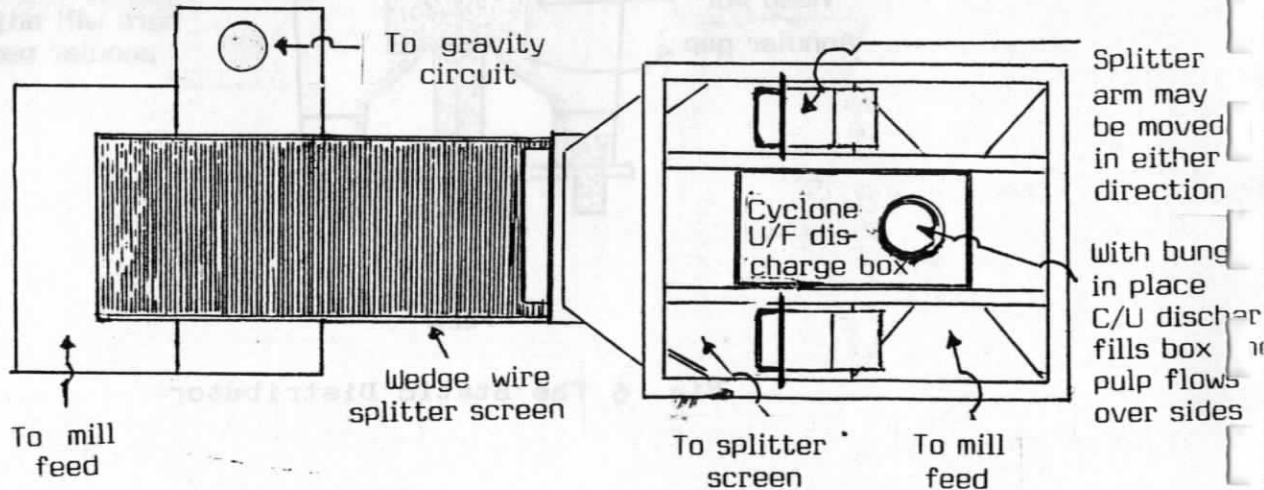

Fig. 5 The Gravity Splitter Box

The feed may also be adjusted by varying the speed of the gravity feed pump. This is necessary when the mill feed has been dropped and it is impossible to get sufficient feed for the gravity pump by adjustment of the splitter arms. At such times the speed will need to be dropped and the water addition

adjusted to provide optimum feed density.

The pulp density may be altered by the addition of water, before the splitter screen, in the gravity feed pump hopper or to the concentrate launder beneath the primary spirals. The latter option adjusts the density of the feed to the cleaner spiral only.

b. The Static Distributor (See fig. 6)

The static distributor at the head of the primary spirals ensures an accurate division of the pulp stream to the spirals. For maximum efficiency a constant head should be maintained in the head pot. The head can be adjusted by either altering the flow rate from the splitter screen and/or altering the annular gap between the head pot and the distributor body, by moving the head pot up or down as required.

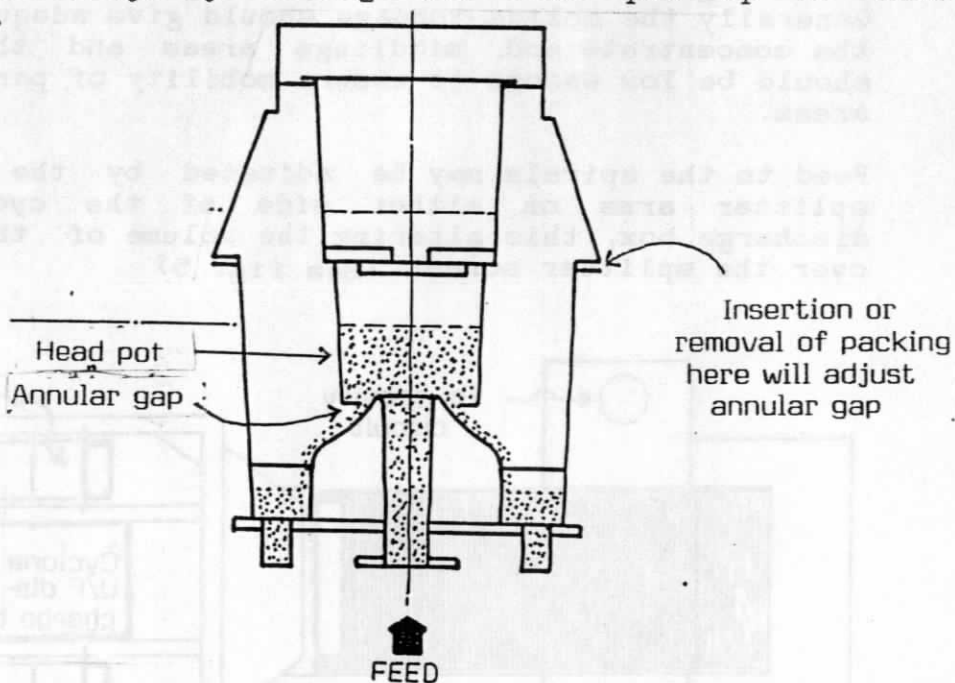

Fig. 6 The Static Distributor

c. The Primary Spirals

Feed from the splitter screen passes down into the gravity feed pump hopper and from there it is pumped to the static distributor above six triplex type primary spirals. As the pulp passes down these spirals; separation of particles occurs according to specific gravity and the heavier minerals progress to the inner profile while lighter minerals are forced towards the outer profile, along with most of the water and slimes. At the bottom of each spiral layer there are splitters which can be adjusted to ensure the optimum recovery of 'coarse gold'. (See fig. 7)

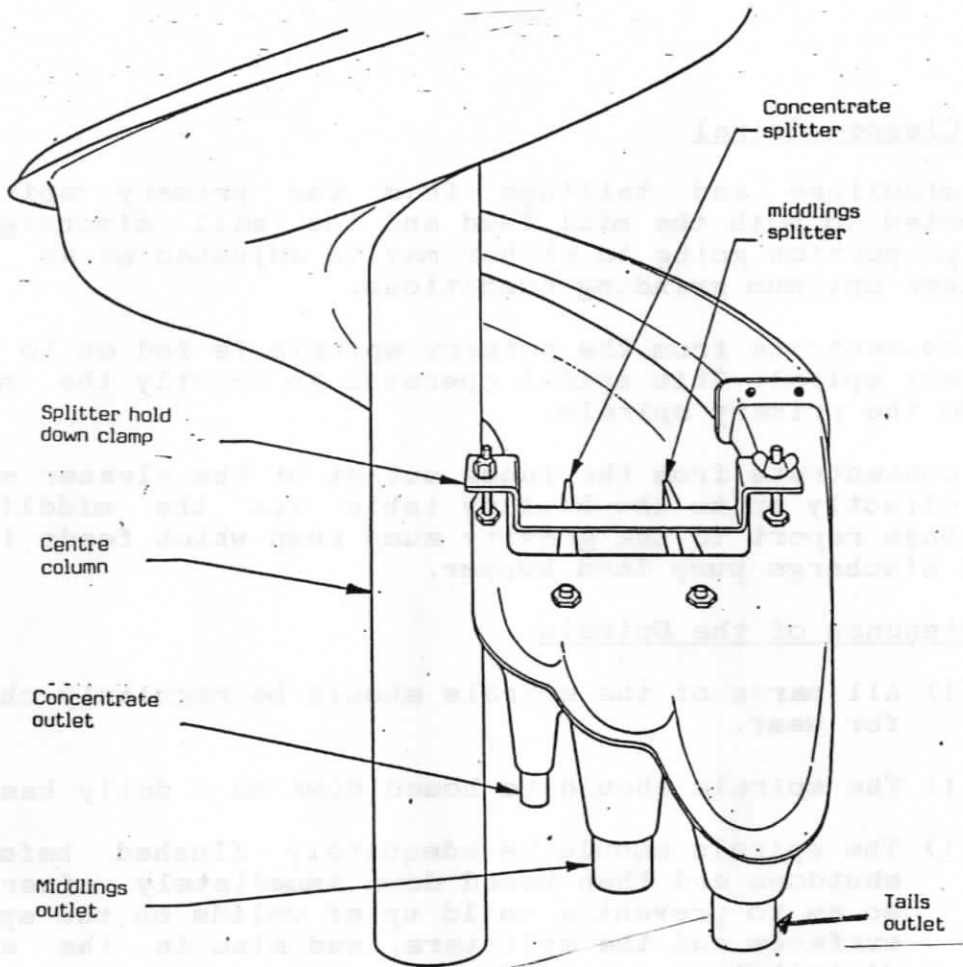
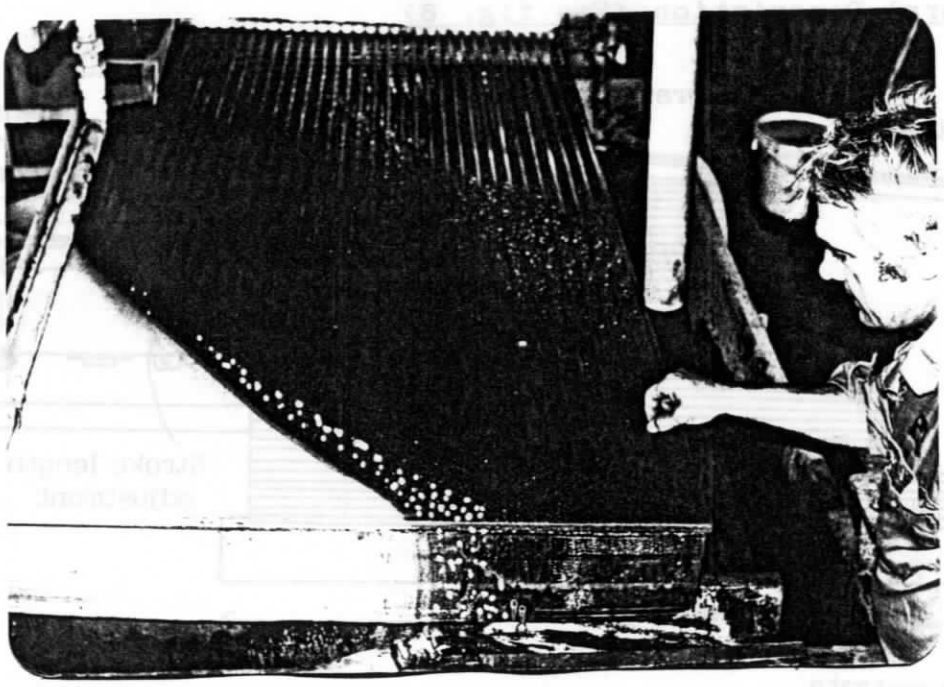

Fig. 7 The Spiral Discharge Splitters



The Wilfley Table Requires Constant Monitoring.

d. The Cleaner Spiral

The middlings and tailings from the primary spirals are directed to both the mill feed and the mill discharge pump. The proportion going to either may be adjusted so as to help achieve optimum grinding conditions.

The concentrate from the primary spirals is fed on to a duplex cleaner spiral. This spiral operates in exactly the same way as do the primary spirals.

The concentrate from the inner outlet of the cleaner spiral is fed directly on to the Wilfley table and the middlings and tailings report to the gravity sump pump which feeds into the mill discharge pump feed hopper.

e. Maintenance of the Spirals

- (i) All parts of the spirals should be regularly checked for wear.
- (ii) The spirals should be hosed down on a daily basis.
- (iii) The spirals should be adequately flushed before a shutdown and then hosed down immediately afterwards so as to prevent a build up of solids on the spiral surfaces and the splitters, and also in the static distributor.

5.3 The Wilfley Table

a. General Description (See fig. 8)

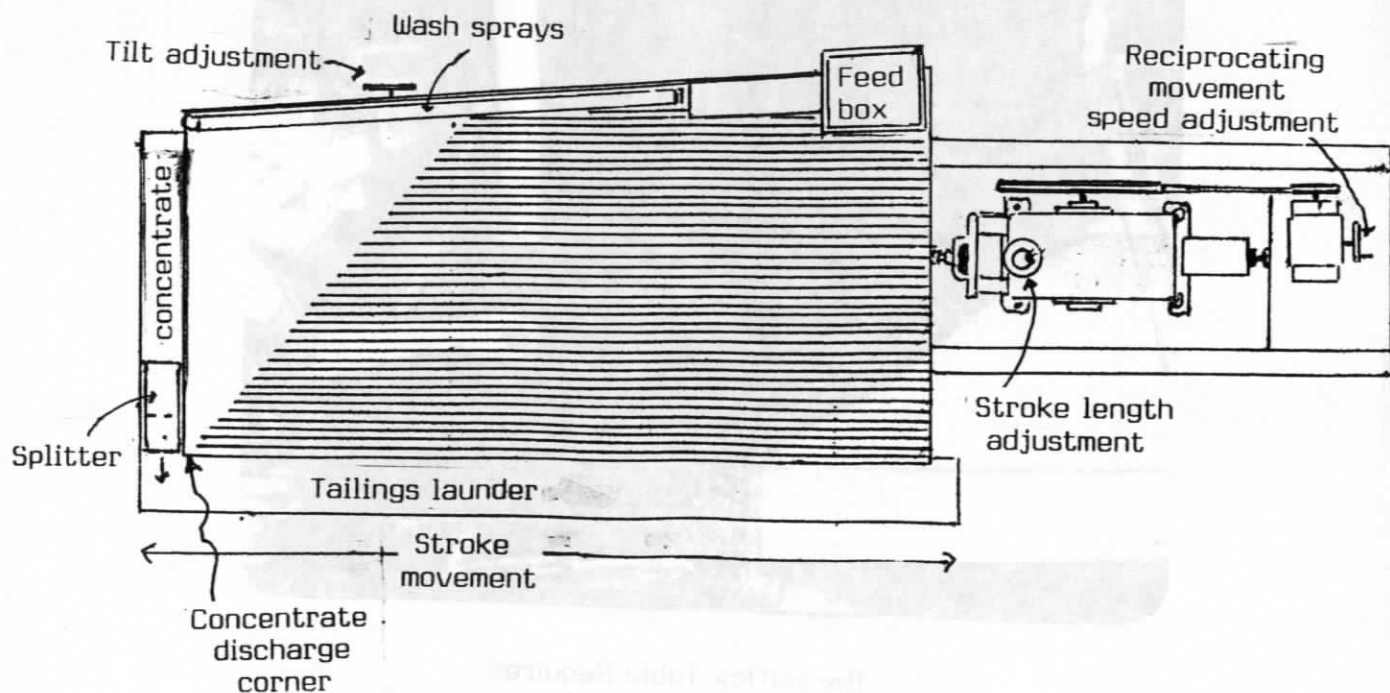

Fig. 8 The Wilfley Table

The Wilfley table is a standard No.12 right hand version. It is a mechanically operated reciprocating action table, consisting of a self-oiling enclosed type of head motion, a partly riffled rectangular deck and an understructure with tilting device for the table.

b. The Head Motion

The head motion is a self-oiling Pitman and toggle type. The motion is created by an eccentric shaft acting on the Pitman with one toggle set and the other toggle connected to a yoke driving the table through a connecting rod. (See fig. 9)

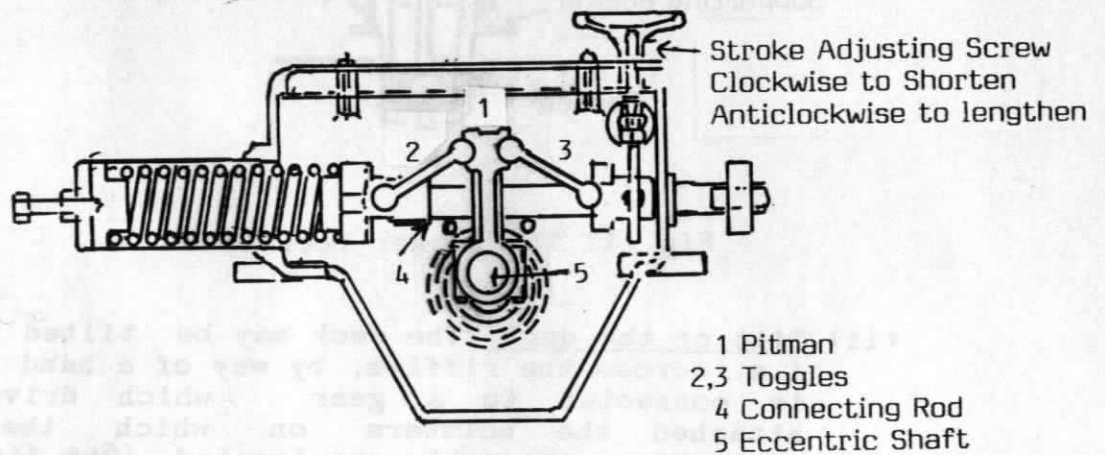
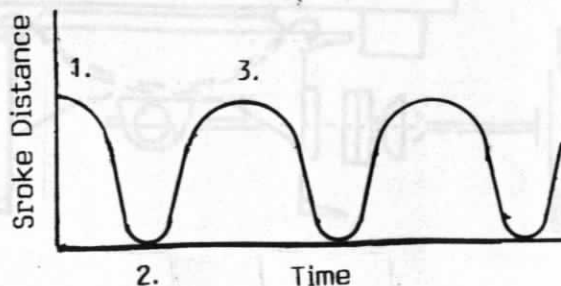

Fig. 9 The Head Motion

This type of motion forms an uneven stroke, slowest at the end of the backward stroke and having increased acceleration towards the end of the forward stroke. (See fig. 10)



- 1. Beginning of Forward Stroke
- 2. End of Forward Stroke
- 3. End of Backward Stroke

Fig. 10 The Stroke Pattern

c. Adjustment of the Deck

- (i) Longitudinal Level: The inclination of the table lengthwise may be adjusted by the raising or lowering of the rocker pockets at each end of the deck. (See fig. 11)

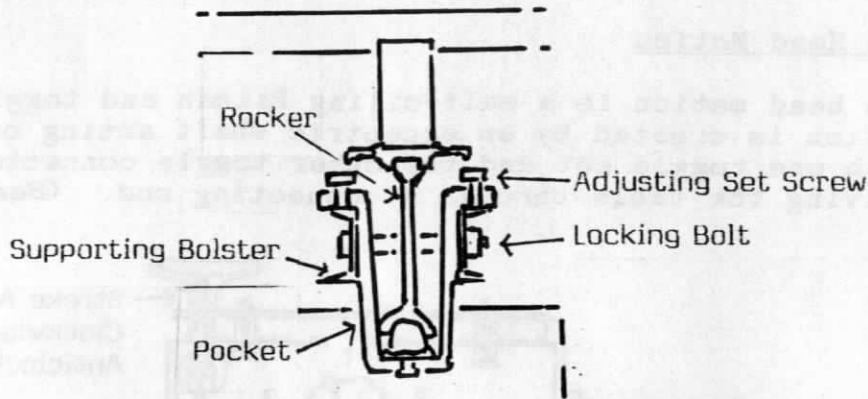

Fig. 11 The Rocker Pockets

- (ii) Tilt of the deck: The deck may be tilted sideways, i.e. across the riffles, by way of a hand wheel that is connected to a gear which drives bolts attached to the bolsters on which the rockers supporting the table are located. (See fig. 12) The forward bolster is linked to the main frame by a tension bar that removes any vibration from the concentrate end of the table.

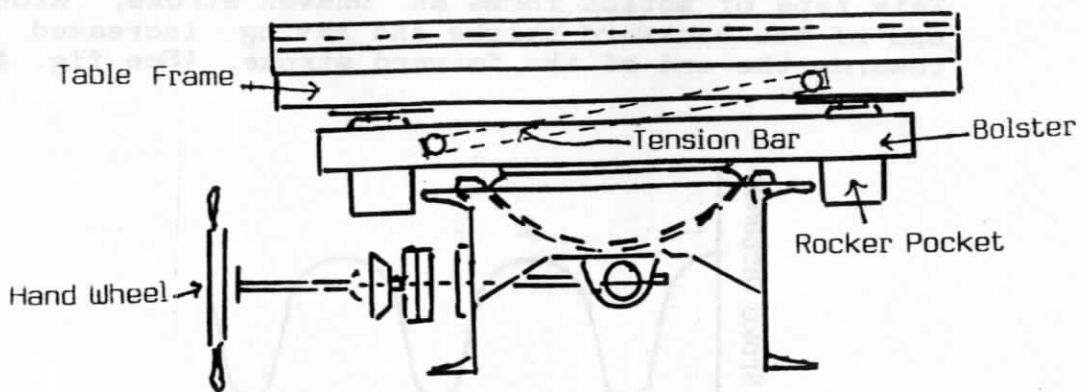

Fig. 12 The Tilting Mechanism

- (iii) Water Wash: The feed edge of the table (See fig. 8) has a water spray bar. This water is adjusted so as to provide a gentle wash across the table.

d. Action of the Table

The action of the table creates inverse classification and stratification, i.e. each mineral of a certain specific gravity is arranged according to size. (See fig. 13)

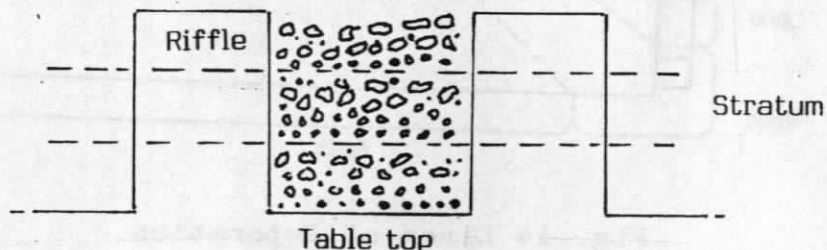

Fig. 13 Inverse Classification and Stratification

Due to the motion the bed moves to the concentrate end. As the height of the riffles decreases towards this end of the table lighter gangue loses the support of the riffles and the wash water carries it towards the lower side of the table into the tails and this then concentrates the remaining heavy mineral. The heavy mineral then moves on to a smooth plane where any fine gangue and larger particles easily rolled by water are washed from the concentrate.

e. Operation of the Table

Feed to the table should be around 25 to 30% solids. If the percentage solids is too high the table may become bogged and separation impaired, this resulting in portion of the heavier material being allowed to pass directly across the table into the tailings launder. Application of wash water should be sufficient to provide a gentle, even flow over the table without the development of heavy riffles across the deck.

Notice should be taken of the type of feed presented and the table must be adjusted to ensure optimum separation. Slimes will require a short, fast stroke with the tilt not far from the horizontal whilst coarse feeds will require a long, slow stroke with a steep inclination. (tilt)

The longitudinal level of the deck may also need to be adjusted to cater for different feed characteristics. This is done by raising or lowering the rocker pockets at each end of the table. Very fine feeds (-175μ) may require the table to be level longitudinally whereas very coarse material may require the concentrate end of the table to be up to 19mm higher than the feed end.

If the table is operating properly there should be a notable classification of 'coarse gold' and the gangue at the concentrate end of the deck with the line of separation coming along the diagonal ending of the riffles and terminating near the concentrate discharge corner of the table. (See fig. 14)

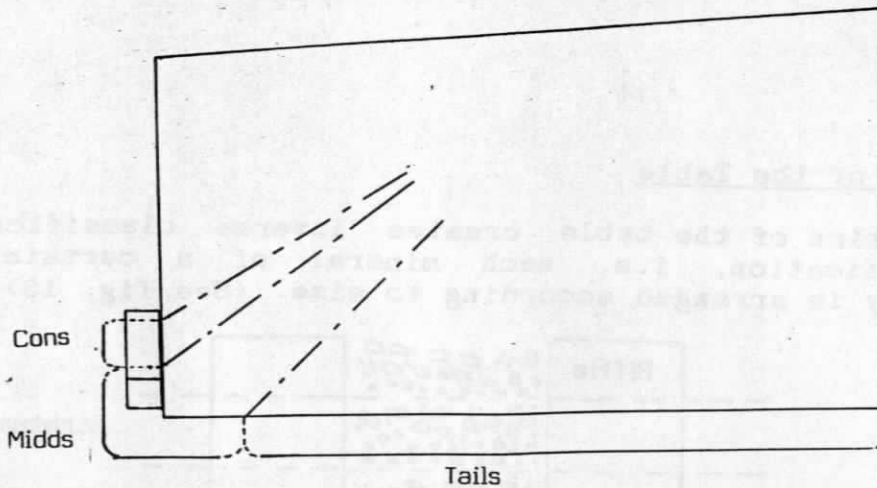

Fig. 14 Lines of Separation

The Quality of the concentrate recovered may be regulated by the movement of the splitter above the concentrate launder. (See fig. 15)

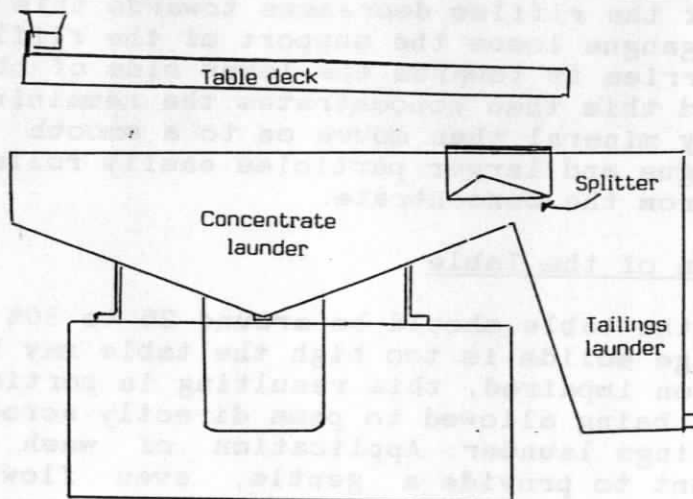

Fig. 15 Concentrate Launder and Splitter

f. Maintenance of the Wilfley Table

- (i) The head motion drive box should be kept topped up to the required oil level.
- (ii) The rocker arm pockets should be kept free of foreign material and topped up with oil.
- (iii) The table should be kept clean, i.e. no build up should be allowed.
- (iv) All parts including the drive belts should be checked on a regular basis for wear.

5.4 Starting Up and Shutdown Procedure for the Gravity circuit

a. Start Up

- (i) Start the gravity sump pump.
- (ii) Start the Wilfley table.
- (iii) Put a bucket below the concentrate launder.
- (iv) Turn on the raw water isolating valve. The 50mm ball valve is accessible from either inside the gold room or from the first landing on the stairs leading up to the stripping plant control panel.
- (v) Ask the mill personnel to put the bung in the cyclone underflow discharge box.
- (vi) Turn on the water addition valve above the gravity feed pump hopper.
- (vii) Start the gravity feed pump.
- (viii) Check that the gravity circuit is operating properly. It may be necessary to adjust the feed and/or the water addition points.

b. Shut Down

- (i) Ask the mill personnel to take out the bung in the cyclone underflow discharge box and also to flush out the gravity feed line and pump hopper. It is preferable that the flushing continue for five minutes at least.
- (ii) Turn off the water addition valve above the gravity feed pump hopper.
- (iii) Stop the gravity feed pump.
- (iv) Close the raw water isolating valve.
- (v) Stop the Wilfley table. Mill personnel may do this by isolating it at the gold room switchboard - during night shift only.
- (vi) Stop the gravity sump pump.
- (vii) Hose down the spirals.

PART 6 - PREPARING OF GRAVITY CONCENTRATES FOR SMELTING

6.1 General

The final concentrate taken off the Wilfley table is not suitable for direct smelting. The 'lines of separation' as shown in fig. 14 (Part 5) are not always clearly defined as there is some intrusion of impurities, namely steel, into the concentrate zone and likewise some gold finds its way into the middlings. It is therefore necessary to include part of the middlings with the concentrate in order to prevent loss of too much coarse gold back into the circuit via the tailings launder.

Hence before the concentrate can be smelted it must be further upgraded. This may be done by purely mechanical means, e.g. re-runs over the Wilfley table, but such methods will invariably also result in the loss of some gold back into the circuit and also require additional labour.

It is preferable that all of the gold in the Wilfley concentrate be retrieved. Two traditional methods of achieving this are *Amalgamation* and *Acid Digestion*. Both methods have been practised throughout Australia for many decades and likewise both offer very good recovery if efficiently employed.

6.2 Amalgamation

This method involves the exposure of gravity concentrate to mercury in a rotating, fully sealed barrel. The mercury amalgamates with any free gold and this product is then separated from the remaining waste for later retorting. Retorting simply involves the heating of the amalgam so that the mercury vaporizes and passes into a condenser barrel leaving the gold 'sponge' behind.

This method is extremely efficient but in recent years the use of mercury with its associated danger has been frowned upon. Hence amalgamation has been rejected as a viable alternative here and for this reason it will not be covered in detail within this manual.

6.3 Acid Digestion

This method, as used here from the commencement of operations, involves the burning away or 'digesting' of impurities by exposing the concentrate to very strong acid solutions. If handled properly it can produce a very pure upgraded concentrate for smelting. It is however subject to censure on four accounts:-

- (i) It involves the use of highly dangerous acids.
- (ii) The Wilfley concentrate must be upgraded by mechanical

means, i.e. as employed here the re-running of it over the Wilfley table, so as to get rid of some of the impurities and in so doing reduce the quantity of concentrate to an amount that may be efficiently treated by acid digestion.

- (iii) Acid digestion does present a security risk in that the daily upgraded product is of a very high quality and its form is such that some could be very easily 'siphoned off'.
- (iv) Some loss of free gold may occur during the decanting off of acid and subsequent rinsing.

It is basically for the above reasons that the use of a more recent development 'Intensive Cyanidation' is being experimented with. However as acid digestion has been practised for so long here, a step by step procedure has been outlined below.

- a. Re-run the concentrate for a twenty four hour period over the Wilfley table in order to both upgrade the concentrate and in so doing reduce it to an amount of no more than 10 to 20 kilos.
- b. Expose this in a large container to hydrochloric acid using approximately two litres of acid to every kilogram of concentrate. Stir regularly.
- c. When the activity has ceased, decant off the acid, via another container, and then rinse the concentrate at least four times by filling the concentrate container with water and stirring; and decanting off each lot of rinse water.
- d. Put half a bucket of water into the concentrate container and then gradually introduce one bucket of nitric acid. Continual stirring is required during this stage and care must be taken to prevent frothing over and loss of concentrate.
- e. When the activity has died down, put the entire concentrate/acid solution mixture into the mechanically agitated vessel and leave it there for at least ninety minutes. This will ensure that all of the concentrate comes into contact with the nitric acid.
- f. Decant off the acid, again into another container.
- g. Rinse the concentrate thoroughly at least three times; decanting off each batch of rinse water into another container.
- h. Should there be any precipitate in the concentrate, this will indicate that not enough nitric acid was used. This can be easily broken down by exposing it to sulphuric acid. Use a 50/50 acid/water mix and put the water into the container

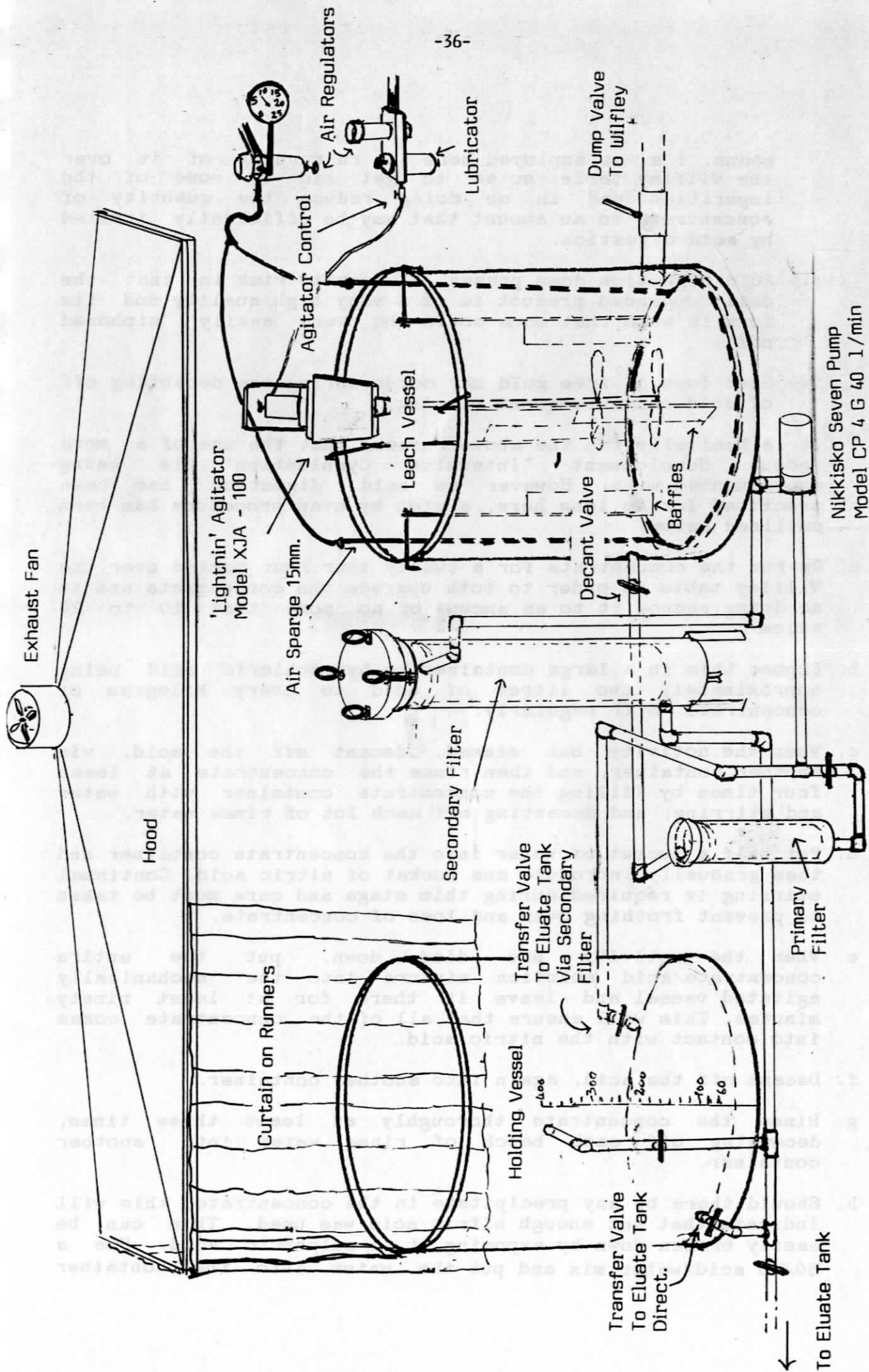

Fig. 16 The Intensive Cyanidation Pilot Plant

first. Only a very small quantity of acid is required - possibly no more than one to two litres at the most. After the precipitate has become entirely fluid, fill the container with water and stir well before decanting off the solution and rinsing the concentrate.

1. Dry the concentrate and after recording the weight, lock it up in the strongroom.

Points to Watch

1. All of the acids are extremely dangerous! Wear protective clothing and a full face mask fitted with a cartridge filter suitable for use in areas exposed to organic acid fumes.
2. All of the digestion work must be carried out under the fume extraction hood.
3. Make sure that the water to the scrubber has been turned on.
4. Rinsing between the hydrochloric acid and nitric acid applications must be very thorough. The two acids when combined will dissolve gold and result in loss whilst decanting off.
5. Any sediment from the containers decanted into must be returned to the concentrate container at each stage.

6.4 Intensive Cyanidation

a. General

The upgrading of gravity concentrate for smelting purposes by use of intensive cyanidation is still in the experimental stage. It involves the leaching out of the gold into solution, using a strong cyanide mix, and then the electrowinning of that solution so as to recover the gold on the steel wool cathodes. This system is capable of handling all of the initial concentrate off the Wilfley table. Because of physical limitations of the present 'pilot plant' it is necessary that the concentrate cut off the Wilfley be limited to 100 kilos every twenty four hours, this being the optimum amount that can be treated efficiently in the leaching vessel. Hence it is necessary for the table to be monitored on a regular basis so as to ensure that not too much gangue gets into the concentrate.

b. Description of the Plant (See Fig. 16)

The Leach Vessel

This vessel has a capacity of 0.75 cubic metres. It is fitted with an air sparge and an air operated agitator that has two

sets of blades, one set located near the bottom of the vessel and the other midway in the optimum charge. The vessel is also fitted with baffles and the floor is sloped towards the 50 mm dump valve. A 25 mm decant valve is located 230 mm from the base of the container.

The Filtration System

The loaded product from the leach vessel is drawn through the decant valve into a primary bag filter (75 microns) and then pumped through a secondary bag filter (1 micron), this removing most of the foreign material before the solution enters the holding vessel.

The Holding Vessel

This vessel is identical to the leach vessel but it has no baffles in it and it is not agitated. It allows the accurate measurement of the loaded leach and rinse solutions and also acts as a storage vessel should it not be convenient to pump the solutions into the eluate tank. Solutions from the holding vessel may be either gravity fed directly into the eluate tank or pumped to it via the filtration system.

c. Operation of the Plant

Charging the Leach Vessel

- (i) Fill the vessel with potable water to the 300 litre mark.
- (ii) Add 6 kgs. NaCN and agitate for around 15 minutes.
- (iii) Put in the concentrate - around 100 kgs.
- (iv) If necessary add NaOH to attain a pH level of >11.
- (v) Note the level of the solution on the vessel. Fill to the same level when putting in subsequent leach and rinse solutions.
- (vi) Start the agitator.
- (vii) Adjust the air sparge to 10 kPa.

Optimum Treatment Time

The duration of each leach and the number of leaches required depends largely upon the quality of the concentrate being treated. The first leach solution loads up very quickly and it is advisable to change it after no more than three hours operation. Hence if a charge is put into the leach vessel late in the morning it should be changed mid afternoon and the final leach left in overnight. Generally only two leaches are necessary with the present plant.

Rinsing and Further Leaching

- (1) Stop the agitator and allow the solution to settle.
- (ii) Decant through the filtration system into the holding vessel.
- (iii) Note the level on the holding vessel and record it on the log sheet.
- (iv) Take a sample and filter it. 150 mls. to go to the laboratory for assaying; and the pH and cyanide levels to be recorded on the log sheet.
- (v) Fill the leach vessel up to the original mark and agitate the solution for 15 minutes.
- (vi) Check to see what stage the current electrowinning is at. If o.k. pump the holding tank out through the filtration system, into the eluate tank.
- (vii) Stop the leach vessel agitator and shut off the air sparge. After settling, pump the solution into the holding vessel. Take a sample for assaying.
- (ix) Fill the leach vessel up again as per section "Charging the Leach Vessel" but do not put any additional concentrate in and only use 4 kgs. of NaCN. Check to see that the pH level is >11 .
- (x) The leach and rinse procedures outlined above are to be repeated for the desired number of times. Always be sure to take a sample of both leach and rinse solutions, and to record the quantities of each, and the pH and cyanide levels of leach solutions.

One rinse must be done between leaches and two rinses done after the final leach.

Dumping of Barren Concentrate

- (i) Open the 50 mm dump valve on the leach vessel. This allows the barren material to go back over the Wilfley table and ensures that any coarse gold, that has not been completely dissolved in the leach vessel, will not be able to escape directly back into the circuit.
- (ii) Hose out the vessel and then close the valve.

Points to Remember

1. For bullion accounting purposes accurate recording is essential. Make sure that the following are completed:-

- (i) Record the quantity of each leach solution.
 - (ii) Record the quantity of each rinse solution.
 - (iii) Take a sample of every leach and rinse solution for assaying.
2. Record the amount of reagents used for each leach.
 3. Record the operating times.
 4. Close the valves after each transfer from either the leach or holding vessel.
 5. Check to see that it is o.k. before pumping out the holding tank.
 6. When there is no strip in progress, fill the eluate tank with at least 15 cubic metres of hot water from the elution column before starting up the electrowinning cell. This aids the electrowinning process and also helps to ensure that any sludge that may have settled on the bottom of the eluate tank is not disturbed.
 7. Check out the filter bags regularly. It is imperative that no solids be allowed to enter the eluate tank.
 8. Cyanide and Caustic are very dangerous! Always wear gloves and safety glasses when working near the plant. The fume exhaust fan should be left operating at all times.
 9. Should there be a power failure during an intensive cyanidation process, only go near the plant if it is absolutely necessary and make sure that you are wearing an appropriate mask, i.e. one that is fitted with a cartridge filter suitable for use in cyanide fumes. Remember that there is no water for washing in during a power failure.
 10. The pilot plant is located almost directly over the barring furnace. Absolute care must be taken when handling fluids so as to ensure that they don't splash or seep on to the ground floor.

d. Further Considerations

Within the constraints offered by the physical inadequacies of the present leaching vessel, it can be asserted that 'intensive cyanidation' is a feasible alternative to the 'acid digesting' of gravity concentrate. However problems are occurring as a result of the input of intensive cyanidation product into the electrowinning system. The cathodes are being clogged up with precipitate and at the time of printing this manual, two cells were in operation instead of the normal one and all of the cathodes were being changed at least twice a week. In the past it has been possible to load at least 70 kgs. of gold on to one lot of cathodes in a single cell, i.e. nine cathodes, with no ill effects upon the operation of that cell.

This problem will have to be overcome as at present too much additional handling of cathodes and cleaning up of sludge build up within cells is necessary. In addition the subsequent acid digestion and rinsing of loaded wool is made difficult by its sludgy nature. Great care is required in order to prevent loss of product back into the C.I.L. circuit.

Obviously the benefits of being able to forward the loaded solution from intensive cyanidation to the electrowinning system are great in terms of both cost and labour savings. Less strips are required each week and this results in substantial cutbacks in the use of reagents, water and gas; and if the present electrowinning problems are overcome, a high grade product for smelting is ensured.



Goldroom Foreman, Ron Wilson, demonstrates how easy it is to control a heavy container on The Granites patented decant platform.

PART 7 - PREPARING CATHODE WOOL FOR SMELTING

7.1 General

The cathode wool is changed every Monday morning or more often if necessary. Sunday's electrowin is however the cut off point. First thing on Monday morning a sample should be taken from the cell for assay and then the eluate solution diverted to the spare cell.

7.2 Removing the Wool

- a. Dump the solution in the cell by opening the drain valve on the line leading back to the eluate tank.
- b. Allow the cathodes to drain for about ten minutes.
- c. Remove each cathode from the cell and place it on the unloading table - ensure that there is a large container under the discharge slide.
- d. Undo the wing nuts and remove the copper contact bar.
- e. Cut away the section of unloaded wool and put the remaining loaded wool into the container.
- f. When all of the cathodes are unloaded, weigh the wool.

7.3 Acid Digestion of the Wool

- a. Put on appropriate safety gear - organic acids mask and rubber gloves.
- b. Place the wool in equal amounts into two large containers and place these on the decant platform. (See fig. 17)

Aciding Container
Sits Inside Tilting
Deck.

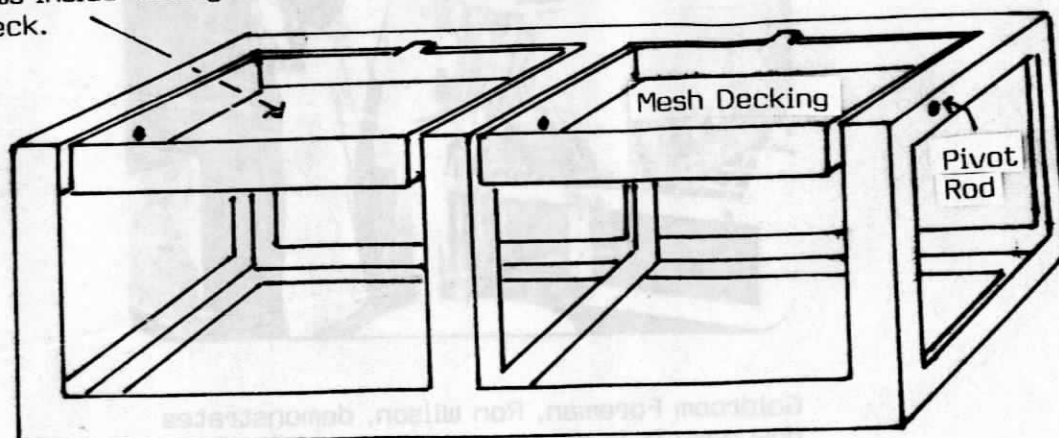
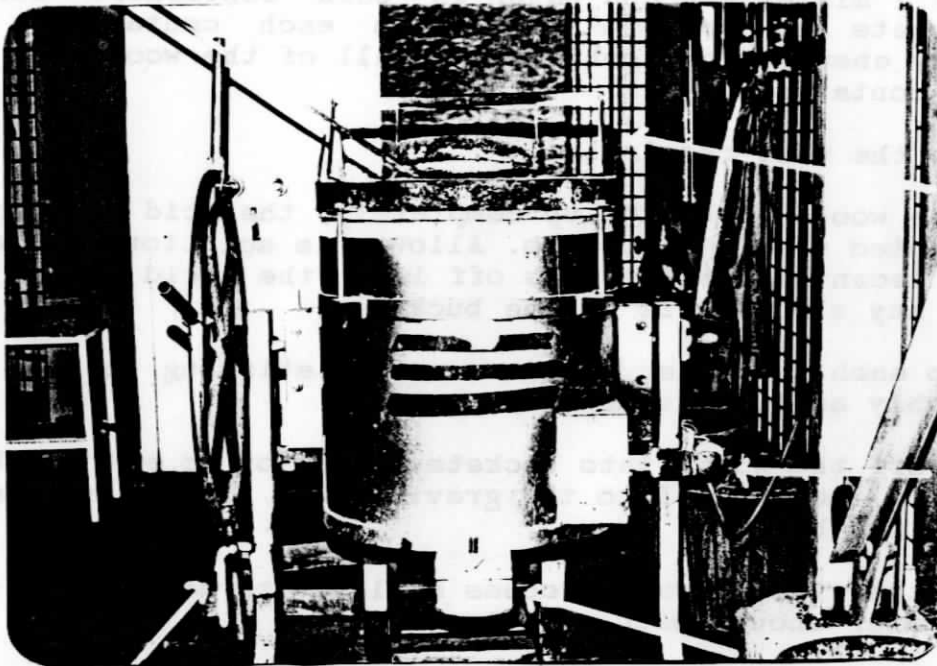

Fig. 17 The Decant Platform

- c. Put a 4:1 mix of HCL and water in each container. Normally two buckets to half a bucket in each container. This quantity ensures good contact with all of the wool. Put lids on the containers.
- d. Stir up the wool regularly.
- e. When the wool has broken up completely, the acid solution may be decanted off into buckets. Allow this solution to settle before decanting the buckets off into the acid area sump. Retain any sludge left in the buckets.
- f. Fill up each container with raw water, stirring up the wool thoroughly as this is done.
- g. Decant off the water into buckets and allow to settle before decanting the water into the gravity sump. Retain any sludge left in the buckets.
- h. Repeat the rinse/decant process at least three times - the rinse water should become quite clear.

7.4 Drying the Cake

- a. Line the large drying tray with newspaper - helps prevent cake from sticking to the metal.
- b. Place the tray on the hot plates and switch the controller to the '4' setting. Do not put on the top setting as it is important that the hot plates don't get red hot.
- c. Place the wool from the final decant in the tray - in an even layer. Put any sludge from the decant on top.
- d. Make sure that the fume exhaust fan is operating.
- e. Stir the cake up at regular intervals to facilitate drying.
- f. Do not over-dry; it is better if the cake is left slightly damp as this helps prevent the loss of fines. When it is dry enough remove the cake from the tray and after weighing it, lock it up in the strongroom. Do not leave it outside of the strongroom The Granite's C.I.L. cake is virtually pure gold/silver - the shrinkage during smelting amounts to less than 5% normally.
- g. Switch off the hot plates.



The cap as modified by Peter Bozic to prevent damage to the furnace lid.

Burner Unit

Latching Mechanism as modified by Herman Buhler in accordance with design by Ian Williams

Counter Weights

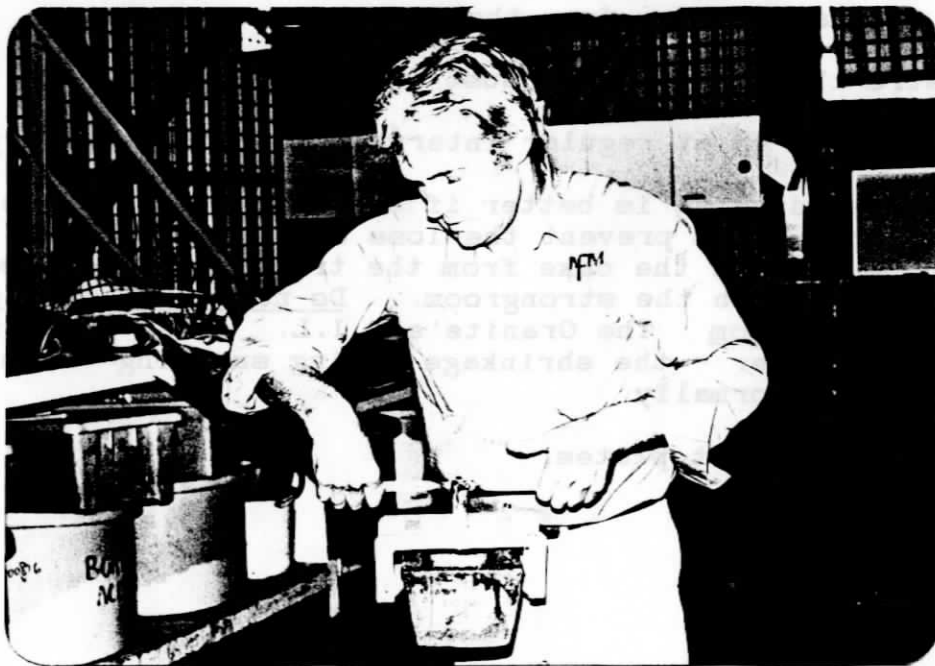

Lifting Device designed and made by Herman Buhler. It makes the handling of loaded moulds much easier.

PART 8 - SMELTING

8.1 The furnace

A tilting type barring furnace is used. It is heated by L.P. gas and the specified maximum rated output of the burner is achieved with a gas pressure of 140 kPa. It is presently operated on 135 kPa, i.e. the maximum attainable pressure from our supply system.

The advantages of using this type of furnace relate mainly to safety and ease of handling. The crucible is fully enclosed even during the pour hence the risk of injury to the operator during a pour is considerably lessened in the event of a mishap. Pouring is relatively easy, a virtual one man operation provided that the furnace has been properly counterbalanced. (See fig. 18)

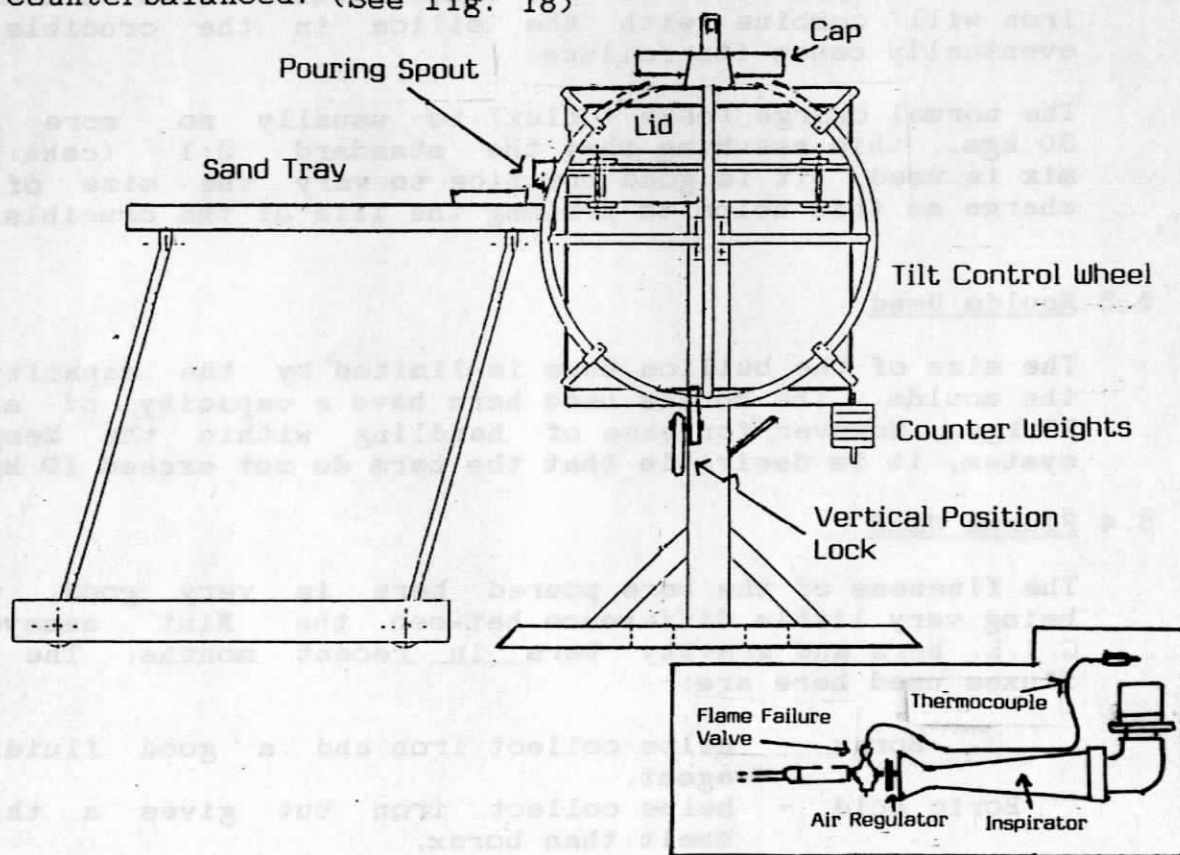

Fig. 18 The Barring Furnace (Inset - Burner Unit)

The only real problem with this type of furnace is that the changing of crucibles is a major task requiring the removal of the furnace lid and extensive fireclay work. Smelting is normally done on a Tuesday. Should a crucible failure occur during the first smelt it would be virtually impossible to put in a new crucible in time to get the gold out on Wednesday as the furnace must be allowed to cool before doing any repair work.

8.2 Crucibles Used

A 100 graphite based crucibles are currently being used. These have been good for about 20 to 25 smelts in the past but they are prone to attack by nitre. Of recent months around 50% of the gold has come from the gravity circuit and whilst the acid digestion of the concentrate from the Wilfley table has improved, it has nevertheless been necessary to use more nitre when smelting that concentrate. With the refinement of the intensive cyanidation system this problem will be avoided as most of our gold will be plated out on cathode wool.

However a silica based crucible will shortly be installed. These are twice as expensive as the graphite based crucibles but with them as much nitre as is required may be used provided that there is an excess of silica in the charge. Any iron in the charge will combine with silica used in the flux to form ferrous silicate. If insufficient silica is used the iron will combine with the silica in the crucible and eventually cause its failure.

The normal charge (cake + flux) is usually no more than 30 kgs., this assuming that the standard 2:1 (cake:flux) mix is used. It is good practice to vary the size of the charge as this helps to prolong the life of the crucible.

8.3 Moulds Used

The size of the bullion bars is limited by the capacity of the moulds. The moulds used here have a capacity of around 23 kgs. However for ease of handling within the despatch system, it is desirable that the bars do not exceed 19 kgs.

8.4 Fluxes Used

The fineness of the bars poured here is very good, there being very little difference between the Mint assays for C.I.L. bars and gravity bars in recent months. The main fluxes used here are:-

- Borax - helps collect iron and a good fluidizing agent.
- Boric Acid - helps collect iron but gives a thicker smelt than borax.
- Silica Flour - provides silicon for slag and helps collect iron.
- Sodium Nitrate - Strong oxidising agent - oxidises iron but very damaging on crucibles if used too generously.
- Soda Ash - Fluidizes slag but works against nitre.

With the development of the intensive cyanidation system in the future it will be possible to use a standard flux mix. In the past it has been necessary to use more sodium nitrate and silica flour when smelting gravity gold.

8.5 Smelting Procedure

- a. Fire up the furnace at least one hour before charging the crucible. For the first thirty minutes keep the gas pressure below 30 kPa and the air addition regulator closed. Fifteen or so minutes before charging turn the gas up to maximum and open up the air regulator fully.
- b. Divide up the total cake into convenient smelting lots. Avoid having very small smelts.
- c. Mix the fluxes according to desired percentages of each, making sure that they are thoroughly blended and all of the lumps broken up. Wear a mask and gloves when handling flux.
- d. Mix the cake and flux together (currently 2:1 mix) and then pour the total charge into paper bags. This helps to prevent loss of fine gold and makes it easier to load the crucible when the furnace is hot.
- e. Turn off the flame - do not attempt to load the crucible whilst the flame is burning.
- f. Load the crucible and put the cap over the charging hole.
- g. Put the gas on maximum and open the air regulator up fully. Put the stirring rod on top of the furnace.
- h. Monitor the smelt regularly. When the charge liquifies it will be necessary to stir it at regular intervals. Make sure that the rod is red hot beforehand.
- i. Warm up the mould - do not over heat - then position it on the sand tray so that it is quite level.
- j. Coat the mould with castor oil just before the pour. This prevents the gold from sticking to it.
- k. The smelt will be ready for pouring when the surface goes flat and there is no movement, i.e. the charge is in a state of 'quiet fusion'. Beware of bubbling around the edge of the crucible - it could mean that the charge needs stirring and it could also mean that the nitre is eating into the crucible wall. The charge will be quite fluid when ready to pour. On an average the first smelt takes ninety minutes and every one thereafter around sixty minutes. (The furnace has by the end of the first smelt achieved its maximum heat.)

- l. Put on the safety clothing and face shield and then pour the smelt in a steady stream. There must be two people present at each pour. (For safety and security reasons)
- m. Allow the loaded mould to cool until the slag has set.
- n. Put on gloves and glasses - then break the bar out of the mould.
- o. If necessary, immerse the bar in nitric acid 50:50 (nitric:water) mix to aid the cleaning process.
- p. Scrub the bar with a wire brush, using soda ash and water.
- q. Stamp with 'GRANITES' on the top of the bar and the bar number, e.g. '0696' on both top and bottom.
- r. Weigh the bar and lock it up in the strongroom.
- s. For each smelt fill in the appropriate details in the 'Process Record' book.
- t. Clean away the slag after each pour and check for prills. Any prills found should go into the next smelt.
- u. After the final smelt record the bar details in the 'Gold Movement' book and inform the office so that the administration representatives can check the weights and lock the bars up in the bullion safe.
- v. Put the smelting safety gear in the strongroom and then lock both combinations.
- w. At the end of each smelt day, check out the crucible thoroughly for wear. Use the calipers to compare the wall thickness with that of a new crucible.

8.6 Points to Watch

1. Beware of fumes - these can be extremely toxic. Fortunately The Granites cake is very clean.
2. Check out the oxygen respirator before commencing smelting.
3. Keep liquids away from the furnace. Keep the floor dry.
4. Keep the goldroom doors locked and make sure that all visitors are signed in. Make sure that they fully understand the rule, 'hands off'.

PART 9 - CARBON REACTIVATION

9.1 General

Fouling of carbon with associated deactivation is fairly rapid in C.I.P. circuits. Acid washing and elution only partially reactivate carbon and so for its repeated use, thermal reactivation after each loading is essential. Reactivation kilns are basically of two types; rotary kilns and vertical kilns. The use of rotary kilns is widespread but generally they have proved to be more expensive in terms of capital and maintenance costs and also they offer low thermal efficiency, when compared with the more recently developed vertical kilns.

The Granites Gold Mine opted for a vertical type kiln. (See fig. 19) Many teething problems were encountered during its first eight months of operation. These were mainly associated with such things as, difficulty in dewatering the carbon prior to its entry into the feed hopper, hanging up of carbon in the feed hopper, fouling of the carbon transfer heat tubes and poor electronic control. Most of these problems have now been overcome.

Better control of the carbon transfer has ensured a moisture content of <50% as per design requirements. This transfer is now carried out after the kiln has reached operational temperatures, this ensuring that much of the residual moisture is vapourized off before it can enter the fire box where in the past it has caused considerable damage to the insulation.

The operation of the kiln was impaired for many months because of difficulty in maintaining a constant feed. Build up on the cone section of the feed hopper interfered with the flow of the carbon into the kiln. This has now been partially overcome by the cleaning of the metal surface and subsequent coating of it with a Teflon film. In addition a small vibrator was fitted to the side of the kiln.

A special reaming device was recently received from The United States. When passed through the carbon transfer heat tubes it effectively removes all build up and this prevents to a great extent the hanging up of carbon within the tubes.

The electronic controls have now been completely modified. It is the desired objective of our maintenance section to make the kiln operation completely automatic, i.e. all that the operators will have to do is put the carbon into the feed hopper, press the 'start' button, monitor the temperatures and take regular samples for activity testing and finally, press the 'stop' button. This is of course an admirable objective but unfortunately it may not prove to be entirely practicable. A feature of this type of kiln is that the rate

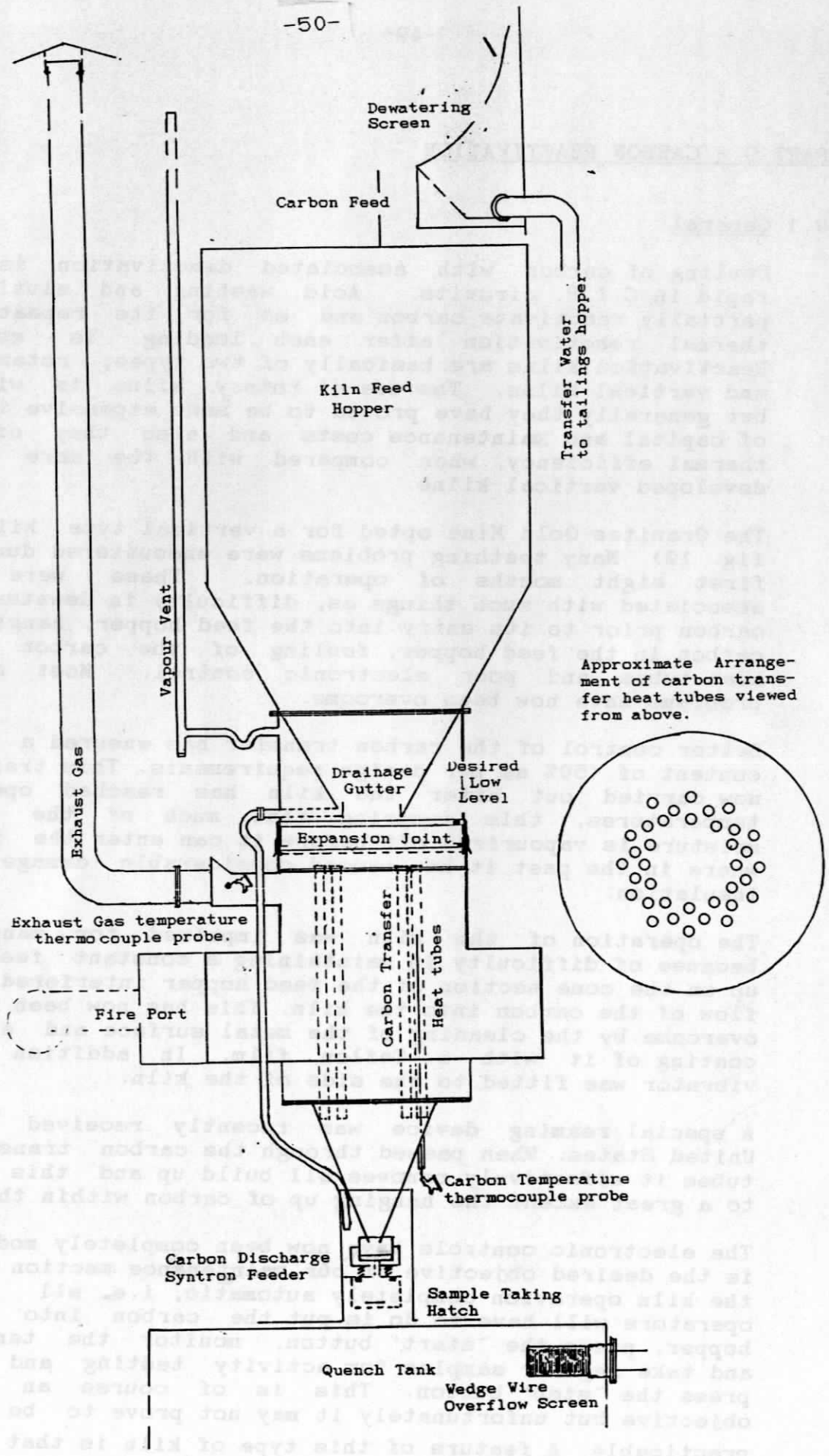

Fig. 19 The Carbon Regeneration Kiln

of carbon movement through it does tend to vary, especially during the early hours of each reactivation. During this period it is desirable that adjustments be made to the discharge feeder setting and/or to the exhaust gas setting. With the present system of controls a change in the discharge feeder setting can upset the controls completely. It is therefore essential that the operators fully understand exactly what each readout display represents and what each control does so that they are completely aware of the consequences of making any adjustment.

9.2 Start Up Procedure (See Fig. 20)

- a. If starting from cold, i.e. a new regeneration:-
 - (i) Make sure that the feeder switch (on the side of the kiln control panel) is in the 'on' position and that feeder setting is on 5.25.
 - (ii) Press the 'start' button.
- b. If starting after a 'high exhaust gas' temperature fault light indicates:-
 - (i) Press the black 'burner reset' button.
 - (ii) Press the 'start' button.
 - (iii) Check to see that there is a carbon discharge.
- c. If starting after a 'burner fault' light indicates:-
 - (i) Reset the black box controller - on the back of the burner unit.
 - (ii) Press the 'start' button.
 - (iii) Check to see that there is a carbon discharge.

9.3 L.E.D. Readouts

- a. High Exhaust Gas This is a safety device working off the exhaust gas thermocouple probe. When the exhaust gas temperature reaches the upper limit of the setting, e.g. as illustrated on fig.20 $450 + 99^{\circ}$, the 'high exhaust gas' temperature light will come on and the kiln will shut down. Restart as per 9.2b above.
- b. Preheat Temperature Readout
This is a safety device designed to protect the kiln from the impact of sudden heating. The burner will operate on 'low fire' until the preheat setting, e.g. 100°C as illustrated in fig. 20, is reached. During this period the green light

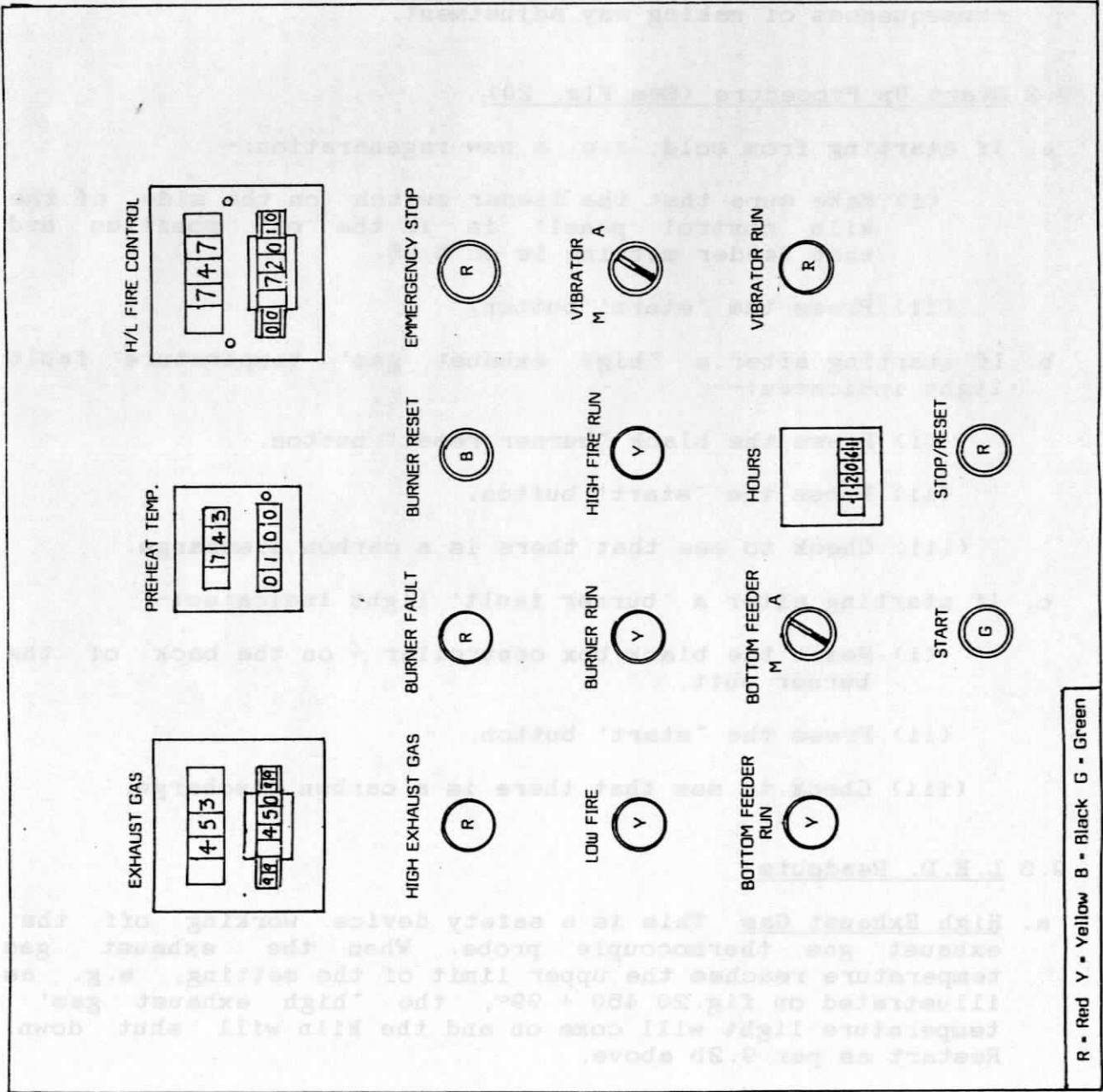

Fig. 20 The Regeneration Kiln Control Panel

will indicate alongside the readout. When the preheat temperature has been reached this light will change to red and:-

- (i) The discharge feeder will start.
- (ii) The 'high' fire will come on.
- (iii) The vibrator will operate intermittently as per a preset cycle.

c. High/Low Fire Control

If the carbon temperature falls below the set point, e.g. as illustrated 720°C, the 'high' flame will come on. When the temperature reaches the upper limit (720 + 10°C), the 'high' fire will go out. The light by the readout will be red when the high fire is off and green when it is on.

9.4 Shutting Down the Kiln

- (i) For normal 'end of regeneration' press the red 'stop/reset' button at the bottom of the panel. The fan only will continue to run for two hours.
- (ii) For emergencies only, press the large red 'emergency stop' button. Everything including the fan, will stop. (Emergency stop buttons will shortly be installed in two positions a safe distance from the kiln. The use of these buttons for anything other than an emergency will cause unnecessary damage to the kiln and burner unit.)

9.5 Adjustment of the Rate of Carbon Discharge

- (i) Switch the 'bottom feeder' switch to 'manual'. The feeder will then run continuously.
- (ii) Adjust the feeder control setting on the box on the side of the kiln control panel. Confirm the rate of discharge by taking a physical sample over 15 seconds and multiplying its weight by 0.24 to obtain kgs./hour. The ideal discharge should be at least 85 kgs./hour and no more than 110 kgs./hour.
- (iii) Switch the 'bottom feeder' switch back to 'auto'.

9.6 Adjustment of Vibrator Intensity

- (i) Switch the (vibrator) switch to 'manual'. The vibrator will then run continuously.
- (ii) Adjust the vibrator control setting on the box on the side of the control panel.

(iii) Switch the 'vibrator' switch back to 'auto'.

9.7 Points to Watch

- a. The rate of carbon discharge setting is critical to the automatic control mode. A sudden increase in the rate of discharge will prompt the 'high' fire to come on and stay on as it is governed by a probe in one of the carbon transfer heat tubes. This will cause a rapid increase in the 'exhaust gas' temperature and could result in a 'high exhaust gas' temperature shut down.
- b. When the exhaust gas temperature readout is very high slow the feeder down and monitor the temperature continuously. Should it be constantly too high with a normal carbon temperature (around 720°C) and likewise a normal discharge rate, it may be necessary to get the electricians to increase the exhaust gas setting. The readout plus the upper limit should never go above 580°C.
- c. Should it be suspected that the carbon is sticking up in the tubes it is permissible to turn up the discharge feeder, e.g. from 5.25 to 5.5, until such time as the carbon runs more freely.
- d. Monitor the kiln regularly. Take hourly samples and label the combined sample:-

"REGEN. NO. _____ STRIP NO. _____ DATE _____ Activity"
- e. Fill in the regeneration log sheet every hour.
- f. Do not let the kiln run empty as it is necessary to have carbon in the tubes for the next start up. The regeneration should be stopped when the carbon in the feed hopper is just above the drainage gutter. (See fig. 19) It is not advisable to leave the cone section covered with carbon as this may result in a build up on the metal surface and subsequent impediment of carbon flow into the kiln. It is hoped to have a low level cut out fitted to the kiln feed hopper soon.

PART 10 - GOLD ROOM GENERAL

10.1 Other Goldroom Duties

- a. Loading of cathodes.
- b. Sweeping/hosing of gold plant area.
- c. Maintaining a stock of bullion boxes.
- d. Carrying out repairs to the barring furnace.
- e. Re-stocking of fluxes.
- f. Re-stocking of reagents.
- g. Reaming out of the regeneration kiln heat tubes.
- h. Cleaning of the heat exchanger plates.
- i. Checking of the thermocal level in the expansion tank and topping up when necessary
- j. Cleaning of the inline screens before each of the gold plant pumps.
- k. Cleaning out of the electrowinning cell, eluate tank and potable water tank when required.
- l. Cleaning of screens in both columns and the quench tank
- m. Cleaning out the sump pump pits.
- n. Regular hosing down of the spirals.
- o. End of period stocktakes.
- p. Monitoring of the condition of all plant and seeing that the required maintenance is carried out.

10.2 Security

It does not matter how honest employees are, if gold is deemed to be missing, ALL persons will be potential suspects. Avoid the possibility of this by observing the following rules.

- a. Keep the goldroom doors, the strongroom and safe doors locked.
- b. Do not leave any cathode cake, gravity concentrate or

smelted products unattended. Lock them up in the strongroom when they are not due for immediate handling.

- c. Maintain very precise records of the movement of all cake, gravity gold and smelted products.
- d. Maintain very precise records of stripping and in particular the intensive cyanidation operations. With the introduction of intensive cyanidation, daily accountability is difficult. In most instances it will not be possible to relate input to output, i.e. head grades with final product, until completion of smelting every Tuesday; under the past acid digestion system there was a degree of daily accountability.
- e. Good sampling is essential! All intensive cyanidation leach and rinse batches must be measured and assayed. Loaded and barren carbon samples must be taken at regular intervals during transfers. Good sampling helps to ensure accurate accounting and accurate accounting provides a back up if the 'books don't balance.'
- f. No gold should leave the goldroom without being recorded in the 'gold movement' record book; the entry duly witnessed. No gold products should be stored outside of the goldroom.
- g. If returning to the goldroom after hours, make sure that the shift foreman is aware of your presence, and preferably note the reason for and time of your visit in the shift log book.
- h. Do not allow any unauthorised person to enter the goldroom. All visitors should be entered in the visitors book.
- i. Do not leave your goldroom keys lying around - or allow others to use them. (Ninety nine percent of the people around this plant would be quite capable of copying them.)
- j. When despatching bullion of a Wednesday morning, keep the goldroom doors locked until such time as the bars have been signed out and all of the necessary paperwork associated with their despatch, completed. Only then should the loaded bullion boxes be taken out to the vehicle and the security guard should be standing by the vehicle when this is done.
- k. Maintain radio contact with the gold movement vehicle until the gold plane has taken off.

10.3 Safety

a. Reagents and Fluxes

This gold plant uses an assortment of reagents and fluxes most of which possess some or all of the following characteristics:-

- (i) Highly corrosive.
- (ii) Highly poisonous
- (iii) Inflammable - if combined with some other reagents or materials.
- (iv) Explosive - when combined with some other reagents or substances.

All employees should read the information sheets at the end of this section relating to individual reagents and fluxes. They should take particular note of the appropriate first aid attention necessary in the case of adverse exposure.

b. Handling

Prevention is better than cure! Wear appropriate safety gear when handling liquid reagents or fluxes. When handling liquid reagents, wear rubber gloves and a full face mask with appropriate cartridge filter. For most goldroom reagents a filter suitable for organic vapours is appropriate but when handling cyanide a cartridge specifically for use in cyanide contaminated areas must be used.

When mixing fluxes, rubber gloves, safety glasses and disposable face mask must be used. Even the most harmless of the fluxes, silica flour, (not included in the information sheets as it does not possess any of the characteristics detailed in section 9.3a) can have serious long term respiratory effects if inhaled.

Extreme care should be taken when drying concentrate or cake. The fumes given off can at times be quite toxic or irritating if inhaled. When in doubt wear a mask! Or hold your breath.

c. General Safety

(i) Normal safety rules apply within the goldroom surrounds. Safety boots must be worn at all times and when working outside of the actual goldroom, a safety helmet must be worn. Safety glasses must be worn in the proximity of the acid and elution columns when they are operating.

(ii) Good housekeeping is essential at all times. Do not leave

things lying on the floor and clean up all spills immediately after they occur.

- (iii) When working on any piece of equipment make sure that it has been appropriately isolated and tagged out at the main control panel
- (iv) If inspecting 'in column screens' or changing heat exchanger plates, ensure that all necessary manual valves are closed and that any associated pumps are isolated and tagged out.
- (v) When working near the furnace on smelting days, full protective clothing must be worn.
- (vi) Always wear gloves when handling slag. Even when cold it can inflict harm as it may be very sharp.

10.4 Reagents - Their Effects on Human Beings, First Aid Requirements, Handling and Disposal.

BORAX

DESCRIPTION White odourless powder.

HAZARDS Acute poison

| | <u>EFFECT</u> | <u>FIRST AID</u> |
|-------------------------|---------------|--|
| <u>PRODUCT IN EYE</u> | Irritant | Irrigate immediately with copious water for 10 minutes. Seek urgent medical attention. |
| <u>PRODUCT ON SKIN</u> | | Wash off with plenty of water, removing affected clothing and washing underlying skin. Clean clothing before re-use. |
| <u>PRODUCT INHALED</u> | | Remove from exposure. Keep warm and at rest. If distressed respiratorily, seek urgent medical attention. |
| <u>PRODUCT INGESTED</u> | Toxic | Wash mouth out with water and give an emetic. Seek urgent medical attention. |

HANDLING Wear fully protective clothing, gloves and full-face mask with respirator.

DISPOSAL Sweep up.

BORIC ACID

DESCRIPTION White crystals or powder.

HAZARDS Toxic by absorption and ingestion. Affects central nervous system

| | <u>EFFECT</u> | <u>FIRST AID</u> |
|-------------------------|---|--|
| <u>PRODUCT IN EYE</u> | Irritant | Irrigate immediately for 10 minutes with copious water. Seek medical attention. |
| <u>PRODUCT ON SKIN</u> | Toxic by absorption if in large quantities. | Wash off with plenty of water, removing affected clothing and washing underlying skin. Seek medical attention. |
| <u>PRODUCT INHALED</u> | | Remove from exposure. If effects persist seek medical attention. |
| <u>PRODUCT INGESTED</u> | Toxic, nausea, vomiting, diarrhoea, shock. | Wash mouth out with water and give water to drink. Seek urgent medical attention. |

HANDLING Wear full protective clothing, mask, rubber gloves and safety glasses. Avoid all unnecessary contact.

STORAGE Store away from strong alkalis.

DISPOSAL Wash away with plenty of water.

CAUSTIC SODA

DESCRIPTION White lumps or sticks

HAZARDS Corrosive on all body tissues. Reacts with water or steam to produce heat

EFFECTS

FIRST AID

PRODUCT IN EYE Severe Burns Irrigate immediately with copious water for 10 minutes. Seek urgent medical attention.

PRODUCT ON SKIN Severe Burns Wash off with plenty of water, removing affected clothing and washing underlying skin. Clean clothing before re-use. Seek urgent medical attention.

PRODUCT INHALED Damage to upper respiratory tract and lung tissue. Remove from exposure. Keep warm and at rest. Seek urgent medical attention.

PRODUCT INGESTED Severe burns. Possible ulceration. DO NOT induce vomiting. Wash mouth out with water. Seek urgent medical attention.

HANDLING Wear fully protective clothing including gloves, safety glasses and boots. Avoid breathing the vapour.

DISPOSAL Flood with copious water.

HYDROCHLORIC ACID

| | |
|--------------------|---|
| <u>DESCRIPTION</u> | Colourless or pale yellow fuming liquid with pungent acidic odour. |
| <u>HAZARDS</u> | Corrosive liquid and vapour |
| <u>FIRE</u> | Non-Flammable. But gives off toxic fumes when heated. Tanks to be kept cool. Safety glasses and breathing apparatus to be worn. |
| <u>EXPLOSION</u> | A contact with some metals will cause highly flammable hydrogen gas to be given off. |

| | <u>EFFECTS</u> | <u>FIRST AID</u> |
|-------------------------|--|---|
| <u>PRODUCT IN EYE</u> | <u>LIQUID</u> : Severe Burns <u>VAPOUR</u> : Burns at high concentration. Irritant at low concentrations. | Irrigate immediately with copious water for 10 minutes. Seek urgent medical attention. |
| <u>PRODUCT ON SKIN</u> | <u>LIQUID</u> : Burns <u>VAPOUR</u> : Irritation | Wash off immediately with plenty of water, removing affected clothing and washing underlying skin. Clean affected clothing. |
| <u>PRODUCT INHALED</u> | High concentrations produce considerable respiratory distress and painful coughing. Possible lung damage. Not voluntarily tolerable. | Remove from exposure, keep warm and at rest. If distressed respiratorily, give oxygen and seek urgent medical attention. |
| <u>PRODUCT INGESTED</u> | Systemic effects not known. | Seek urgent medical attention. <u>DO NOT</u> induce vomiting. |

| | |
|-----------------|--|
| <u>HANDLING</u> | Wear fully protective clothing, full face mask with respirator and rubber gloves. |
| <u>STORAGE</u> | Do not store in containers made of common metals. |
| <u>DISPOSAL</u> | Avoid contact with liquid. Extinguish source of ignition. Flood with water bearing in mind that the first run off will be highly corrosive. Inform authorities if a major spillage occurs. |

LIME

DESCRIPTION White amorphous powder.

HAZARDS Reacts vigorously with water giving off considerable heat. Similar reaction with steam, acids or acid fumes.

EFFECT FIRST AID

PRODUCT IN EYE Severe Burns Irrigate immediately with copious water for 10 minutes and seek urgent medical attention.

PRODUCT ON SKIN Severe irritant. Wash with plenty of soap and water. Remove affected clothing and clean before re-use.

PRODUCT INHALED Irritant to mucous membranes and upper respiratory tract. Remove from exposure. Keep warm and at rest. If distressed respiratorily, seek urgent medical attention.

PRODUCT INGESTED Toxic affects. Wash mouth out with water and give plenty of water to drink. Seek urgent medical attention.

HANDLING Wear full protective clothing, mask, gloves and safety glasses.

DISPOSAL Flush away with water.

NITRIC ACID

DESCRIPTION Colourless or yellowish fuming liquid.

HAZARDS Corrosive, Emits highly toxic fumes of oxides and nitrogen. When heated to decomposition, reacts with water to emit toxic fumes.

FIRE Non-Combustible.

| | <u>EFFECTS</u> | <u>FIRST AID</u> |
|-------------------------|---|---|
| <u>PRODUCT IN EYE</u> | Severe Burns | Irrigate immediately with copious warm water while seeking urgent medical attention. |
| <u>PRODUCT ON SKIN</u> | Burns | Wash with plenty of warm water, removing affected clothing and cleaning before re-use. Seek urgent medical attention. |
| <u>PRODUCT INHALED</u> | Irritant - will cause pulmonary damage. | Remove from exposure, keep warm and at rest. Seek urgent medical attention. |
| <u>PRODUCT INGESTED</u> | Severe internal irritation. | Wash mouth out thoroughly with water. and seek urgent medical attention. |

HANDLING Wear gloves and full face mask with respirator. Avoid breathing the fumes.

STORAGE Store separate from metallic powders, carbides, hydrogen sulphide, turpentine, organic acid and all combustible, organic and other readily oxidisable materials.

DISPOSAL Spread soda ash, if available, over the area and mop up cautiously with water. Run to waste and continue diluting with running water.

SODA ASH

DESCRIPTION White odourless crystalline powder.

HAZARDS Poisonous if taken internally.

EFFECT

FIRST AID

PRODUCT IN EYE Irritant

Irrigate immediately with copious water for 10 minutes.

PRODUCT ON SKIN Blisters?

Wash off with plenty of water, removing affected clothing and cleaning before re-use.

PRODUCT INHALED Irritant

Remove from exposure, keep warm and at rest. If distressed respiratorily, seek urgent medical attention.

PRODUCT INGESTED Poisonous

Wash mouth out with water, give water to drink. Seek urgent medical attention.

HANDLING Avoid dust

DISPOSAL Mop up with water and run to waste, diluting with water.

SODIUM CYANIDE

| | | |
|--------------------|--|--|
| <u>DESCRIPTION</u> | White crystalline powder | |
| <u>HAZARDS</u> | Emits toxic and flammable vapour on contact with acid, acid fumes, water or steam. | |
| <u>FIRE</u> | Extinguish with dry powder, alcohol foam or carbon dioxide. | |
| <u>EXPLOSION</u> | Explosive when decomposing to hydrocyanic acid. Reacts violently with nitrite and nitrate. | |

| | <u>EFFECTS</u> | <u>FIRST AID</u> |
|-------------------------|---|--|
| <u>PRODUCT IN EYE</u> | Corrosive | Irrigate immediately with copious water for 10 minutes. Seek urgent medical attention. |
| <u>PRODUCT ON SKIN</u> | Irritant and may cause secondary infection. | Wash with plenty of water, removing affected clothing and washing underlying skin. Clean clothing before re-use. |
| <u>PRODUCT INHALED</u> | Poisonous - may cause loss of appetite, headache, nausea, dizziness and upper tract irritation. | Remove from exposure. Keep warm and at rest. Seek urgent medical attention. |
| <u>PRODUCT INGESTED</u> | Highly poisonous | Induce vomiting and seek urgent medical attention. |

| | | |
|-----------------|---|--|
| <u>HANDLING</u> | Wear rubber aprons, rubber gloves and respirator. No smoking. | |
| <u>DISPOSAL</u> | Sweep up. DO NOT flush with water. | |

SODIUM NITRATE

DESCRIPTION Colourless, odourless crystals with a slightly bitter taste.

HAZARDS Explosive when mixed with finely divided combustible materials, cyanides, sodium hypophosphite. Highly toxic when ingested.

| | <u>EFFECT</u> | <u>FIRST AID</u> |
|-------------------------|--|--|
| <u>PRODUCT IN EYE</u> | Irritant | Irrigate immediately for 10 minutes with copious water. Seek medical attention. |
| <u>PRODUCT ON SKIN</u> | Irritant | Wash off with plenty of water, removing affected clothing and washing thoroughly before re-use. If effects persist seek medical attention. |
| <u>PRODUCT INGESTED</u> | Gastro-enteritis, abdominal pains, vomiting, muscular weakness, irregular pulse, convulsions and collapse. | Wash mouth out with water and give an emetic. Seek urgent medical attention. |

HANDLING Wear full safety clothing, mask, rubber gloves and safety glasses. Avoid dust inhalation.

STORAGE Store in a dry place away from strong reducing agents and organics.

DISPOSAL Sweep up and wash spillage area thoroughly with water.

FIRE FIGHTING Ignites on friction when mixed with organic material. Use water spray extinguisher and wear approved respirator.

REFERENCES

Clyde Carruthers Handbook

"Operation, Maintenance and Installation Instructions for Clyde Wilfley Concentrating Table No.12, Serial No. 2143, October 85."

Comsteel Vickers Limited (Fine Minerals Engineering Division)

"Installation and Operations Manual for Vickers FG Spirals and Vickers Static Distributor, November 85."

Kleenheat Gas Handbook

"Operating Instructions for Westfarmers Kleenheat Gas Pty. Ltd. Gold Melting Furnace - Tilting Type."

Mount Percy Mining Services Pty. Ltd.

"Operations Manual."

Western Australian Mining and Petroleum Research Institute Report No. 2.

"Carbon-in-Pulp Gold Processing Technology - Project No. 10."

| | |
|--|----------------------|
| Wear full safety clothing, mask, rubber gloves and safety glasses. Avoid dust inhalation. | <u>HANDLING</u> |
| Store in a dry place away from strong reducing agents and organics. | <u>STORAGE</u> |
| Wash up and wash splashed area thoroughly with water. | <u>DISPOSAL</u> |
| Ignites on friction when mixed with organic material. Use water spray extinguisher and wear approved respirator. | <u>FIRE FIGHTING</u> |