

THE NEW HYDRAULIC INSTITUTE PUMP INTAKE DESIGN STANDARD

by

Jack Claxton

Vice President, Engineering
Patterson Pump Company
Toccoa, Georgia

George E. Hecker

President

Alden Research Laboratory
Holden, Massachusetts

and

Arnold R. Sdano

Director of Engineering
Fairbanks Morse Pump
Kansas City, Kansas



Jack Claxton is Vice President, Engineering, of Patterson Pump Company, in Toccoa, Georgia. He has 23 years of experience in the hydraulic design, mechanical design, application, and field troubleshooting of many types of vertical and centrifugal pumps. He is a member of ASME and is active in the Hydraulic Institute, where he currently serves as Chairman, Intake Committee; Chairman, Vibration Committee; and Chairman,

Vertical Pump Section.

Mr. Claxton has a B.S.M.E. degree from Georgia Tech and is a registered Professional Engineer in the State of Georgia.

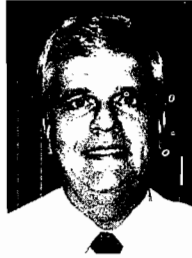

Arnold R. (Arnie) Sdano is Director of Engineering for Fairbanks Morse Pump, with unit wide engineering responsibilities for the Pentair Pump Group, in Kansas City, Kansas. He has previously managed engineering departments at Peerless Pump Company, LaBour Pump Company, and Allis-Chalmers Custom Pump Division for a professional period spanning the past 25 years. Mr. Sdano also is active in pump industry standards development through

the American Water Works Association, and the Submersible Wastewater Pump Association. He holds several U.S. and foreign patents for pump designs.

Mr. Sdano has a B.S.M.E. degree from the University of Wisconsin, is a registered Professional Engineer in the State of Wisconsin, and is active in the Hydraulic Institute where he serves as chairman of the Education Committee.



George E. Hecker has been President of the Alden Research Laboratory, Inc. (ARL), in Holden, Massachusetts since 1986, and previously worked at Stone & Webster and TVA. With 35 years of experience, he has conducted and supervised hundreds of model, analytical, and field studies on pump intakes, piping systems, fluid mechanic equipment, and flow patterns at intakes. He is particularly well known for his work on characterizing free surface

vortices and evaluating scale effects in models. Many of his publications appear in referenced journals, conference proceedings, and ARL reports.

Mr. Hecker has a B.E. degree from Yale University, an M.S. degree from MIT, and is a member of ASCE and IAHR. He has served on many national and international committees, has been consultant to private industry and various U.S. Government agencies, and is currently a member of the HI Intake Design Committee.

ABSTRACT

A balanced committee of users, designers, researchers, and pump manufacturers has produced a revised Hydraulic Institute Pump Intake Design Standard that is considerably different from the existing standard and more comprehensive. An overview of the new features of the revised standard is provided. The discussion focuses in depth on selected portions of the new document, including rectangular intakes, trench type intakes, and the concept and use of "design bell diameter." The basis for the minimum submergence rule, hydraulic modelling requirements, scope, and acceptance criteria are covered.

DISCLAIMERS

- The Hydraulic Institute Pump Intake Design Standard is still in a draft format at the time of this publication. Changes may occur before the final standard is published.

• Only select portions of the standard are described in this tutorial. A complete copy of the standard must be reviewed before attempting to design an intake per the Hydraulic Institute Pump Intake Design Standard.

INTRODUCTION

When the current American National Standards Institute/Hydraulic Institute (ANSI/HI) standards for vertical and centrifugal pumps were undergoing the approval process a few years ago, a number of comments were received that indicated the intake design portion of the standards needed a substantial revision. As a result of those comments, in February 1994, the Hydraulic Institute formed a balanced committee of end users, intake designers, researchers, and pump manufacturers to improve that portion of the standard. The result of five years of work by this committee is a new, different, comprehensive standard dedicated solely to the subject of pump intake design that approaches 50 to 60 pages in length. The standard at the time of this writing is undergoing an approval process to become a joint ANSI/HI standard.

OVERVIEW OF THE NEW STANDARD

- The standard is essentially a new document that is expected to approach 50 to 60 pages in length.
- The standard will be published as a standalone document.
- Both free surface intakes and closed conduit suction piping are included.
- Design recommendations for intakes for solids-bearing liquids, in addition to clear liquids, are included.
- The standard includes design recommendations for the following new intake types:
 - Formed suction intakes (clear liquids)
 - Circular intakes (clear liquids)
 - Trench intakes (clear liquids)
 - Suction tanks (clear liquids)
 - Barrel or can intakes (clear liquids)
 - Unconfined intakes (clear liquids)
 - Trench (solids-bearing liquids)
 - Circular intakes (solids-bearing liquids)
 - Rectangular intakes (solids-bearing liquids)
 - Suction piping
- The rectangular intake, clear liquids section is all new as compared to previous HI standards.
- There is a thorough discussion of problem intakes in the remedial measures' section in the appendix, and common "fixes" are presented in an organized fashion, according to the type of problem. The problems addressed include:
 - Poor approach flow patterns
 - Controlling cross-flows
 - Expanding concentrated flows
 - Pump inlet disturbances
 - Surface vortices
 - Subsurface vortices
 - Preswirl
 - Suction tank remedial measures
- Tutorial material, which may seem contradictory and confusing when presented together with specific design recommendations, is in the appendix.
- An extensive section on model testing is provided, with specific test requirements (model size, flowrates, instrumentation, methods,

etc.) and acceptance criteria. The standard allows an intake that is not designed according to the standard, but is model tested according to the standard and found to meet the acceptance criteria specified, to be in compliance with the standard.

- A section on sump volume is provided in the appendix.
- A section on intake basin conditions is provided in the appendix.
- A section on submergence has been provided. The recommended minimum submergence is a function of the bell diameter and Froude number that relates flow and bell diameter. This method of obtaining submergence is used throughout the standard, for all the intake types.
- A section is provided entitled "Inlet Bell Design Diameter." This section describes the intake design procedure to determine an "inlet design bell diameter" for intake design purposes, when the specific pump and bell diameter is not yet known. The section provides acceptable tolerances for the bell diameter ultimately to be used when the intake has been designed according to the rectangular (clear liquids) intake design recommendations using the inlet bell design diameter.
- A glossary and nomenclature section are provided in the appendix.
- A step-by-step design procedure is provided in the rectangular (clear liquids) section. The geometry of this intake type is based partly on velocity criteria, and partly on the bell geometry. As stated previously, the submergence is based on a function of bell diameter and the Froude number. (Past Hydraulic Institute intake design standards have been based on the rated flowrate of the pump.)
- For rectangular (clear liquids) intake types, a criterion is provided to evaluate cross-flows at the intake inlet, and model testing is required if the criterion is exceeded.
- Other specific criteria are provided throughout the standard that specifies under what conditions model testing is required.
- Metric units of measurement are used, and corresponding U.S. units appear in brackets. Charts, graphs, and sample calculations are also shown in both metric and U.S. units.
- A flow chart is provided at the front of the standard to facilitate use of the standard and to show how the various sections might relate to each other during an intake design process.

FLOW CHART FOR USE OF STANDARD

It should be noted, and the user of the standard is strongly cautioned, that the chart does not comprise the complete standard, and it is not a substitute for the understanding of the complete standard. The flow chart is intended as a guide to the use of the standard. It allows the user to readily see what sections are provided in the standard that might be appropriate to the application at hand. The user is not directed by the standard to use one intake type versus another (this topic is beyond the scope of the standard). Please refer to the flow chart shown in the APPENDIX.

INSIGHT INTO SELECTED PORTIONS OF THE STANDARD

Due to the extensive nature of the standard, time and space would prohibit this tutorial from addressing the entire standard. Instead, selected portions are discussed to provide a sample of its contents. They are the following: TUTORIAL MATERIAL IN THE APPENDICES, APPLICATION OF STANDARD—RECTANGULAR INTAKE DESIGN—CLEAR LIQUIDS, and APPLICATION TO STANDARD—INTAKES FOR SOLIDS-BEARING LIQUIDS.

TUTORIAL MATERIAL IN THE APPENDICES

The material pertaining to the various intake types that is tutorial in nature has been placed in appendices in the back of the document, and they are not part of the standard. These appendices

contain some information that provide a fuller understanding of the problems the intake designer is trying to avoid. Corrective measures are discussed and shown that may be of benefit to the user should a problem intake be encountered. Considering that rectangular intake, clear liquids, and design standards will be addressed later in this tutorial, a richer understanding of the standard design material might be gained by considering first the types of problems encountered in these intake types. This is covered in Appendix A in the new document. Appendix A is entitled "Remedial Measures for Problem Intakes."

REMEDIAL MEASURES FOR PROBLEM INTAKES, RECTANGULAR TYPE

Introduction to Appendix A of the Standard

The material presented in Appendix A of the standard is provided for the convenience of the intake design engineer in correcting unfavorable hydraulic conditions of existing intakes. A portion of the material in Appendix A transmits general experience and knowledge gained over many years of improving the hydraulics of intake structures. Appendix A concentrates on rectangular intakes for clear liquids, but the basic principles can be applied to other types of intakes. The material is organized by the general type of hydraulic problem in an upstream to downstream direction, since proper upstream flow conditions minimize downstream remedial changes. Problems discussed in Appendix A include:

- Approach flow patterns, general
- Open versus partitioned structures
- Controlling cross-flow
- Expanding concentrated flows
- Pump inlet disturbances (free-surface vortices, subsurface vortices, and preswirl)

Approach Flow Patterns, General

The characteristics of the flow approaching an intake structure is one of the foremost considerations for the designer. Unfortunately, local ambient flow patterns are often difficult and expensive to characterize. Even if known, conditions are generally unique, frequently complex, so it is difficult to predict the effects of a given set of flow conditions upstream from an intake structure on flow patterns in the immediate vicinity of a pump's suction. Considerations for determining direction and distribution of flow at the entrance to a pump intake structure are provided.

Figure 1 shows two examples of illustrations from Standard Figure A-2-1, depicting rectangular intake structures withdrawing flow from both moving bodies of liquid and stationary reservoirs. Figure 2 shows two examples of illustrations from Standard Figure A-2-2, which depict several typical approach flow conditions for different combinations of pumps operating in a single intake structure.

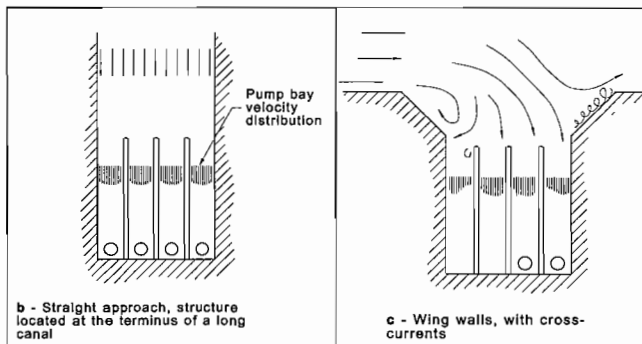

Figure 1. Examples of Approach Flow, All Pumps Operating. (Courtesy Hydraulic Institute)

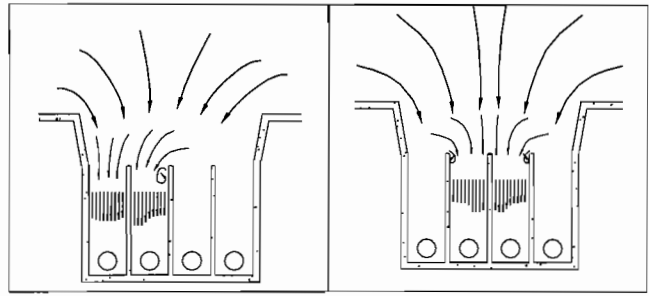

Figure 2. Examples of Approach Flow, Select Pumps Operating. (Courtesy Hydraulic Institute)

Open Versus Partitioned Structures

In the example of multiple pumps in a single intake structure, the advantage of using dividing walls placed between the pumps is discussed, as are the disadvantages of open sump designs. An illustrated comparison of flow approaching the pumps in both a partitioned structure and an open sump is provided, with discussion.

Controlling Cross-Flow

If cross-flow is present (i.e., if the pump station is withdrawing flow from the bank of a canal or stream), trash racks with elongated bars can provide limited assistance in distributing flow as it enters the pump bay. Guidelines are provided on how to achieve maximum effectiveness in guiding flow. Other flow straightening devices for minimizing cross-flow effects at bay entrances are illustrated.

Expanding Concentrated Flows

Two methods for correcting flow disturbances generated by expansion of a concentrated flow are described:

- *Free-surface approach*—This is where site conditions dictate that the approach flow channel or conduit, although in line with the sump axis, is much smaller than the sump width. To avoid concentrated flow and large eddies, the side walls approaching the pump bays must gradually diverge, and flow baffles of varying geometry may be used to spread the flow at a divergence angle greater than otherwise possible. Possible corrective measures are shown. The special problem of dual flow screens is discussed (the flow leaving a dual entry flow screen requires baffling to break up and laterally distribute the concentrated flow prior to reaching the pump).

- *Closed conduit approach*—This pertains to flow provided to rectangular intake structures through a conduit. When multiple pumps are installed perpendicularly to the influent conduit, the flow pattern improves, and approach velocities decrease if the sump walls diverge gradually from the point of influent toward the pump bays. Maintaining a small angle divergence of each wall from the influent conduit minimizes the difficulty in spreading the flow uniformly. The use of flow distribution baffles is discussed and illustrations are provided.

Pump Inlet Disturbances

- *Free-surface vortices*—There are a number of factors that have an effect on the formation of surface vortices. To achieve a higher degree of certainty that objectionable surface vortices do not form, modifications can be made to intake structures to allow operation at practical depths of submergence. The use of suction umbrellas, vertical curtain walls, and horizontal gratings to inhibit vortex formation are discussed.

- *Subsurface vortices*—The geometry of boundaries in the immediate vicinity of the pump bells is one of the more critical

aspects of successful intake structure design. It is in this area that the most complicated flow patterns exist and flow must make the most changes in direction, while maintaining a constant acceleration into the pump bells to prevent local flow separation, turbulence, and submerged vortex formation. Pump bell clearance from the floor and walls is an integral part of the design. Figure 3 depicts a wall splitter plate, floor splitter plate, and floor cone. This figure depicts three of nine devices in Standard Figure A-5-2 that represents a sampling of various devices to address subsurface vortices.

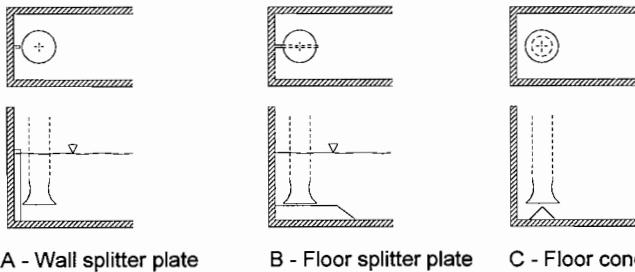

A - Wall splitter plate B - Floor splitter plate C - Floor cone

Figure 3. Methods to Reduce Subsurface Vortices. (Courtesy Hydraulic Institute)

- **Preswirl**—Whether preswirl exists to an objectionable extent is governed primarily by the approach flow distribution. A sufficiently laterally skewed approach flow causes rotation around the pump bell, in spite of the local features. The most effective way of reducing preswirl is to establish a relatively uniform approach flow within each pump bay by using the baffling schemes discussed in the sections above pertaining to approach flow patterns, controlling cross-flow, and expanding concentrated flows. How final reductions in swirl may be achieved near the pump bell is discussed.

APPLICATION OF STANDARD— RECTANGULAR INTAKE DESIGN—CLEAR LIQUIDS

Use of the new 1999 HI Standards for Pump Intake Design (Section 9.8, called “HI Standard” herein) will be illustrated by application to a rectangular pump sump (intake) with multiple pumps for clear liquid. It will be assumed that a pump vendor has not yet been selected at the time of the intake design but that the flow per pump is known, as is the proposed use of single pass versus dual flow screens, and that a formed suction intake (FSI) will not be used. Table 1 shows Table 9.8.2.1-2 from the Standard and gives a typical sequence of steps in the HI Standard design process.

Prior to use of specific sections in the HI Standard, the design engineer should read Appendix A “Remedial Measures for Problem Intakes,” since this material gives an overview of how to achieve a favorable approach flow pattern to the intake structure itself. The arrangement and shape of wing walls, the extent to which the intake structure is recessed into the bank of a liquid body, and means to expand concentrated approach flow from conduits should be evaluated. However, the remedial devices to correct possible flow disturbances discussed in Sections A-5, “Pump Inlet Disturbances,” are usually not incorporated in an initial intake design, as the selection and sizing of remedial devices depend on detailed knowledge of the flow pattern near the pump.

Since the HI Standard calls for sump dimensions in multiples of the pump bell diameter, that diameter must be known or assumed, to dimension the sump. If the final pump has not been selected, Section 9.8.6, “Inlet Bell Design Diameter,” provides a means for selecting a bell diameter that complies with the HI Standards. This recommended inlet bell design diameter is based on a survey of pumps that vendors would offer for certain flows and also considers field experience with pumps. The recommended design

Table 1. Design Sequence, Rectangular Intake Structures. (Courtesy Hydraulic Institute)

Design Step	Description
1	Consider the flow patterns and boundary geometry of the body of liquid from which the pump station is to receive flow. Compare with the approach flow condition described in Section 9.8.2.1.1 and determine from Section 9.8.5.1 if a hydraulic model study is required.
2	Determine the number and size of pumps required to satisfy the range of operating conditions likely to be encountered.
3	Identify pump inlet bell diameter. If final bell diameter is not available, use the relationship in Figure 9.8.6-1 to obtain the inlet bell design diameter
4	Determine the bell-floor clearance, see Figure 9.8.2.1-1. A good preliminary design number is 0.5D.
5	Determine the required bell submergence, using the relationship in Section 9.8.7.
6	Determine the minimum allowable liquid depth in the intake structure from the sum of the floor clearance and the required bell submergence.
7	Check bottom elevation near the entrance to the structure and determine if it is necessary to slope the floor upstream of the bay entrance.
8	Check the pump bay velocity for the maximum single-pump flow and minimum liquid depth with the bay width set to 2D. If bay velocity exceeds 0.5 m/s (1.5 ft/s), then increase the bay width to reduce to a maximum flow velocity of 0.5 m/s (1.5 ft/s).
9	If it is necessary to increase the pump bay width to greater than 2D, then decrease bay width in the vicinity of the pumps according to Figure 9.8.2.1-2.
10	Compare cross-flow velocity (at maximum system flow) to average pump bay velocity. If cross-flow value exceeds 50% of the bay velocity, a hydraulic model study is necessary.
11	Determine the length of the structure and dividing walls, giving consideration to minimum allowable distances to a sloping floor, screening equipment, and length of dividing walls. If dual flow traveling screens or drum screens are to be used, a hydraulic model study is required (see Section 9.8.5.1, Need for Model Study).
12	If the final selected pump bell diameter and inlet velocity is within the range given in Section 9.8.6, the sump dimensions (developed based on the inlet bell design diameter) need not be changed and will comply with these standards.

bell diameter is based on achieving an average velocity (using the inlet bell O.D.) of 5.5 ft/sec at the bell inlet face. For small pumps with flows/per pump less than 5000 gpm, the bell may produce average inlet velocities of 2.0 ft/sec to 9.0 ft/sec and still meet the HI Standard. For flows per pump between 5000 gpm and 20,000 gpm, the average inlet velocity may range from 3.0 ft/sec to 8.0 ft/sec, and for flows per pump greater than 20,000 gpm, the average inlet velocity may range from 4.0 ft/sec to 7.0 ft/sec. Use of velocities less than the lower limit of these ranges will produce a large and unnecessarily expensive intake structure (sized in proportion to the larger bell), and velocities higher than the upper limit of these ranges appear related to pump operating problems. A higher velocity range is allowed for smaller pumps, as these are generally more rugged, and the inlet structure will be small. The inlet bell design diameter, D , may be calculated or the graphs in Figures 9.8.6-1a and 1b may be used. The bell floor clearance should be set from $0.3D$ to $0.5D$.

Inlet Bell Submergence

By selecting the minimum bell submergence to prevent objectionable free-surface vortices, the elevation of the intake floor will be established, since the minimum liquid level for the site is usually available or can be calculated by including head losses in the approach canal or piping. Generally, the minimum submergence for obtaining the required net positive suction head (NPSH) will be lower than needed to minimize free-surface vortices, but this should be checked in each case.

Section 9.8.7, “Required Submergence for Minimizing Surface Vortices,” gives the rationale for and the equation that provides the recommended minimum submergence above the bell inlet. A critical parameter for vortex formation is the extent of circulation or rotation in the flow approaching the pump, but this is usually not known or even quantifiable. The extent of circulation will depend on the approach flow direction, how many pumps are operating, on the intake geometry, and the exact pump inlet setting. A second relative variable is the velocity at the bell inlet face, which is known and is incorporated into a dimensionless parameter called the Froude number.

For typical intake geometries and relatively uniform approach flow (i.e., low values of the circulation), data and experience indicate that the following recommended relationship between

relative submergence and the dimensionless Froude number would correspond to an acceptable (non air core) vortex strength.

$$S/D = 1.0 + 2.3 F_D \quad (1)$$

Where:

- S = Submergence above inlet bell entrance
- D = Inlet bell O.D.
- F_D = Froude number = $V/(gD)^{0.5}$
- V = Velocity at inlet bell face = flow/area using O.D.
- g = Acceleration due to gravity

This Equation shows that the relative submergence is not fixed, but varies with the inlet Froude number. For average pump sizes and the recommended inlet velocity of 5.5 ft/sec, the required relative submergence will be about two inlet bell diameters.

Bay Dimensions and Velocity

The total liquid depth in the intake at the pump is the sum of the bottom clearance and the submergence. Figure 4 (Standard Figure 9.8.2.1-1) shows the remaining recommended geometry of a rectangular intake in terms of the inlet bell design diameter, D, which has been determined. Notice that the width of any bay near the bell should be 2D, and together with the total liquid depth, gives the minimum approach flow area. The latter should be used to calculate the bay approach velocity to the pump, and this velocity should not exceed 1.5 ft/sec. If the velocity is greater than 1.5 ft/sec, the bay width upstream from the pump should be increased to more than 2D and side fillers used at the pump to obtain a width of 2D (Figure 5, Standard Figure 9.8.2.1-2). Minimum lengths for the dividing bay walls are 5D from the pump centerline (Figure 4, Standard Figure 9.8.2.1-1). Note that the dividing walls extend fully to the back wall of the intake, so that there are no unexpected lateral flows to a bell when an adjacent pump is not running. The floor shall be level for at least this same 5D distance. Any through flow screens must be at least 4D from the pump centerline. Converging side walls beyond 5D from the pump should have angles less than 10 degrees; diverging side walls are not a recommended feature of an HI Standard design. Floor slopes beyond 5D must be less than 10 degrees, but can be sloped downward (as shown) or upward.

If an intake is designed to a geometry other than that presented in this standard, and this design is shown by prototype or model tests performed in accordance with Section 9.8.5 to meet the acceptance criteria in Section 9.8.5.6, then this alternative design shall be deemed to comply with this standard. This allows compliance with contracts that require the intake to meet HI Standards, and yet have an alternative intake geometry, which may be more advantageous for a particular site or application.

Hydraulic Model Studies

A hydraulic model study shall be conducted for a rectangular pump intake, if one or more of the following apply:

- The sump geometry deviates from the HI Standard.
- The cross-flow velocity upstream from the intake face is more than 50 percent of the pump bay entrance velocity.
- Dual flow or drum screens are proposed.
- Flows are greater than 40,000 gpm per pump, or the total station flow (with all pumps running) is greater than 100,000 gpm.
- Proper pump operation is critical, and pump repair, remediation of a poor design, and the indirect impacts of inadequate performance or pump failure would altogether cost 10 times or more than a model study.

Selection of the model scale ratio is based on achieving minimum Reynolds and Weber numbers to minimize scale effects,

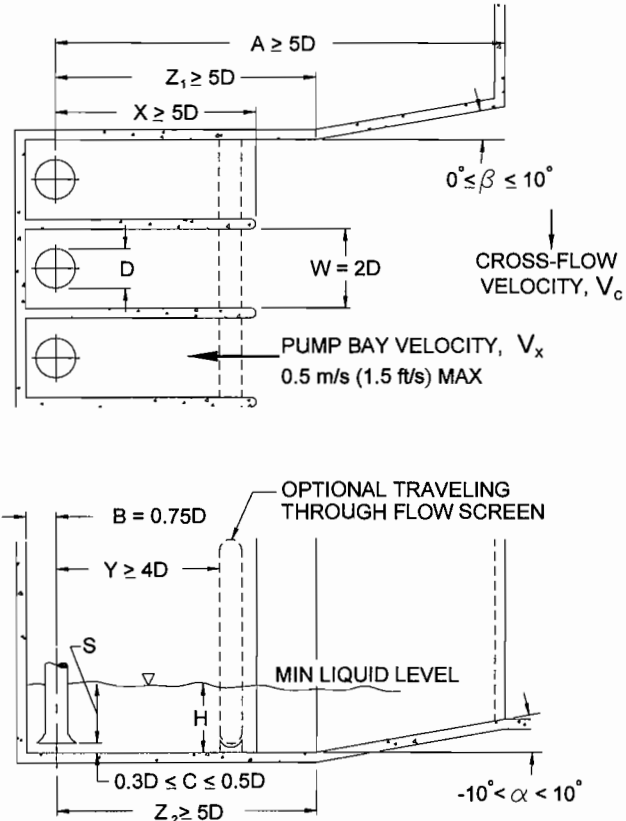

Figure 4. Recommended Intake Structure Layout. (Courtesy Hydraulic Institute)

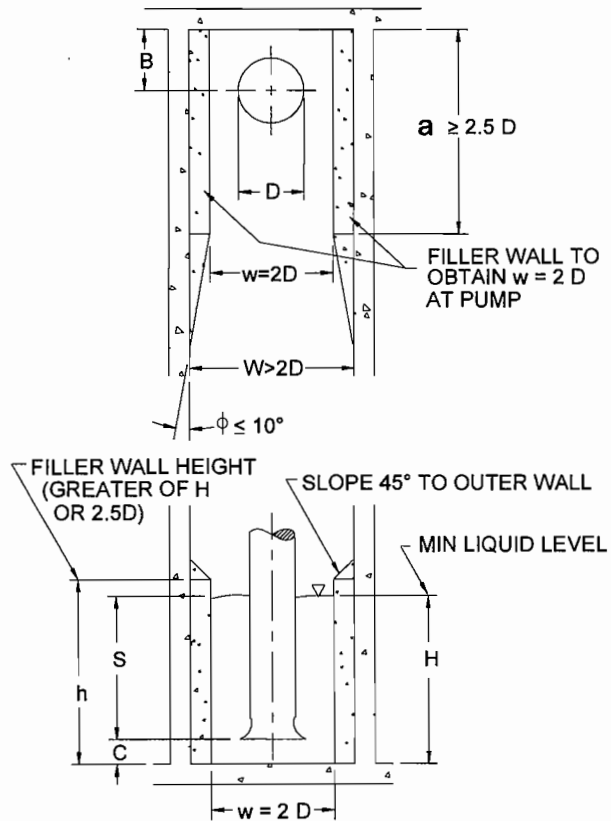

Figure 5. Filler Wall Details for Proper Bay Width. (Courtesy Hydraulic Institute)

while operation of the model is based on equal Froude numbers between model and prototype. Reynolds number is a dimensionless grouping of parameters that indicates the relative influence of inertial compared with viscous forces. Weber number is a dimensionless grouping of parameters that indicates the relative influence of inertial compared with surface tension forces. And, as previously noted, the Froude number is a dimensionless grouping of parameters that indicates the relative influence of inertial compared with gravitational forces. Thus, a large pump and intake can be modelled using a smaller scale, e.g., 1/12, than a small pump and intake, which will need a larger scale, e.g., 1/6, to meet the minimum Reynolds and Weber numbers. Boundary conditions must be selected carefully to ensure that the flow pattern (circulation) is correctly modelled. The HI Standard describes objectionable flow irregularities, and how they should be observed and measured. An intensity scale for free and submerged vortices is provided for consistent observations, and the type of swirl meter and velocity measurements in the bell throat are prescribed. An important aspect is that criteria are listed for the final design relative to acceptable intensities and persistence of vortices, the allowed average and maximum swirl angles, and the maximum permissible variation in local bell throat velocity from the cross-sectional average velocity. General requirements for the test plan and report are also provided.

The intent is to standardize when a physical (hydraulic) model is needed, model design and operation, data collection, and the flow conditions, which are acceptable for the final design. This will ensure that the model study is done correctly and that flow patterns entering the pump are favorable for pump operation. Analytical modelling, such as computational fluid dynamics (CFD), is not acceptable.

Final Pump Selection

To comply with the HI Standard, the selected pump must have a bell within the range specified in Section 9.8.6, and preferably should have a bell that produced an average velocity of 5.5 ft/sec, using the bell O.D. to calculate the flow area. In the latter preferred case, the bay width for each pump will be $2D$, as specified in the HI Standard. If the final pump bell is larger or smaller than the recommended design diameter (with $V = 5.5$ ft/sec), but is still within the specified range, then the previously designed bay width will not be exactly $2D$ but will still comply with the HI Standard, and the preselected bay width does not need to be changed. However, all reasonable attempts should be made to select a pump with a bell close to the recommended bell design diameter to minimize the change from the desired sump width and other sump dimensions.

APPLICATION OF STANDARD— INTAKES FOR SOLIDS-BEARING LIQUIDS

General

Recognizing that wet wells for solids-bearing liquids often require special design considerations, the HI Standard now includes a separate extensive section to help promote a better understanding of these requirements.

The objective of this section of the HI Standard is to introduce design features recommended for wet wells used in solids-bearing liquid applications. These features are intended to minimize accumulations of solids and provide for easier cleaning, thereby reducing maintenance. This section applies specifically to installations where the pumped liquid contains solids that may float or settle in the wet well. Fluids such as wastewater, industrial discharges, storm or canal drainage, combined wastewater, and some raw water supplies are included in this category.

The primary goal of an intake designed to handle solids-bearing liquids, as it is with all HI Standard designs, is to provide an intake that produces a uniform flow pattern at the inlet to the pump when

operated within the normal liquid levels and flowrates. The second goal of an intake designed to handle solids-bearing liquids is to reduce the tendency for buildup of solids in the intake, and a third goal is to allow for the easy removal of settled or floating solids.

If the solids are allowed to build up in the intake structure, the solids will frequently induce intake disturbances that are harmful to the pump's operation and life. For the case of municipal sewage, organic solids accumulations not removed may become septic, causing odors, increasing corrosion, and releasing hazardous gases. Specific wet well geometry and provisions for cleaning of the intake structure, to remove material that would otherwise be trapped and result in undesirable conditions, is now covered by the HI Standard.

Specific design requirements are detailed for three different types of solids handling wet well geometries. These designs are:

- Trench-type wet wells
- Circular plan wet wells
- Confined rectangular wet wells

Principles of Design

Horizontal surfaces in the wet well anywhere but directly within the influence of the pump inlets must be minimized, thereby directing all solids to a location where they may be removed by the pumping equipment. Vertical or steeply sloped sides shall be provided for the transition from upstream conduits or channels to pump inlets. Trench-type wet wells, circular plan wet wells, and confined rectangular wet wells have been found to be suitable for this purpose.

Transitions between levels in wet wells for solids-bearing liquids shall be at steep angles (60 degree minimum for concrete, 45 degree minimum for smooth-surfaced materials such as plastic and coated concrete—all angles relative to horizontal) to prevent solids accumulations and promote movement of the material to a location within the influence of the currents entering the pump intakes.

Horizontal surfaces should be eliminated where possible except near the pump inlet (Figures 6 and 7, Standard Figures 9.8.3.2-1 and 9.8.3.2-2). The horizontal surface immediately in front (for formed suction inlets) or below (for bell inlets) should be limited to a small, confined space directly in front of or below the inlet itself. To make cleaning more effective, the walls and floor forming the space must be confined so that currents can sweep solids to the pump inlet.

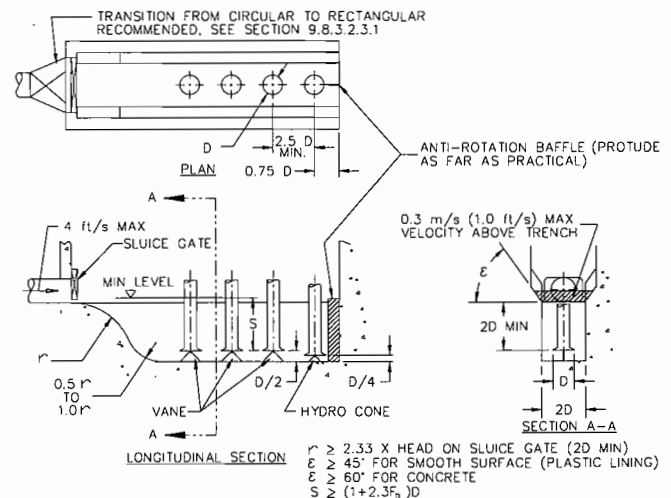

Figure 6. Open Trench-Type Wet Well. (Courtesy Hydraulic Institute)

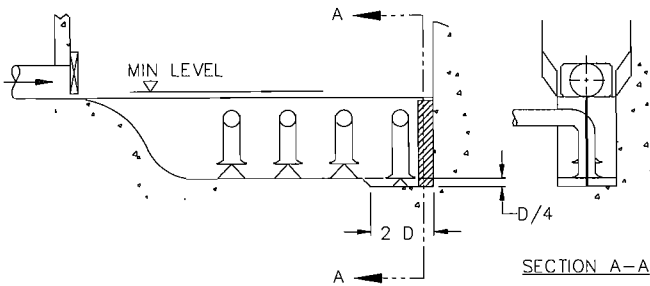

Figure 7. Open Trench-Type Wet Well for Pumps Sensitive to Loss of Prime. (Courtesy Hydraulic Institute)

Cleaning Procedures

Removal of solids from wet wells, designed in accordance with these principles, can be achieved by operating the pumps selectively to lower the level in the wet well until the pumps lose prime. Both settled and floating solids are removed by the pumping equipment and discharged to the force main (or discharge conduit). This cleaning procedure momentarily subjects the pumps to vibration, dry running, and other severe conditions. The intake designer must consult the pump manufacturer before selecting the pumping equipment. The frequency of cleaning cycles is dependent on local conditions, and therefore should be determined by experience at the site.

Alternatively, liquid jets or mixers positioned to create horizontal and vertical currents can be used intermittently or continuously to maintain suspension, and direct floating and settled solids toward the pump intakes. The solids are swept into the pump intake for removal. Caution should be exercised when using jets or mixers, to avoid inducing continuous currents near pump inlets that could result in damage to the pumping equipment.

Wet Well Volume

Wet wells for variable speed pumping stations designed to match outflow with inflow need not be designed for storage, but rather only to accommodate the inlets and the geometry required for velocity limitations and cleaning.

Wet wells for constant speed pumps should be constructed to minimize size for economy and to facilitate cleaning. One approach is to provide storage for pump regulation in the upstream conduit or channel, as well as in the wet well itself. Appendix B of the HI Standard provides guidance on sump volume for constant speed pumps and Appendix C explains how to design for storage in the upstream conduit.

Design of Trench-Type Wet Wells

The trench-type wet well design, suitable for solids-bearing liquids such as stormwater, wastewater, and canal-type pumping stations, is presented as an example of the type of designs covered in the HI Standard.

Like most wet well designs in this section, the trench-type sump volume is minimized to prevent areas for accumulation of solids. The compactness of this design can significantly reduce the excavation volume over a traditional rectangular intake design and, when combined with the reduced cleaning maintenance, makes this an economical design to consider.

Trench-type wet wells are designed to provide a uniform inlet flow to the pump while operating at normal liquid levels. They minimize the buildup of solids while running, and allow for cleaning of the wet well using a special procedure at reduced liquid levels. This meets the three stated goals for these types of intakes.

Experience has shown that trench-type wet wells, with an ogee transition between the entrance conduit and the trench floor, provide optimum geometry for efficient cleaning operations. The HI Standard provides guidance on the geometry necessary to induce scouring velocities during this cleaning procedure.

Trench-type wet wells can be used with both constant speed and variable speed pumping equipment. There is no difference between wet wells for variable as compared with constant speed pumps, but there is a difference between inlet conduits for the two kinds of pumping stations. With variable speed pumps, there is no need for storage, because pump discharge equals inflow. Consequently, the liquid level in the wet well can be made to match the liquid level in the upstream conduit.

When constant speed pumps are used, the liquid level must fluctuate—rising when pumps are off and falling when they are running. There must be sufficient active storage to prevent excessive frequency of motor starts. As trench-type wet wells are inherently small and not easily adapted to contain large volumes of active storage, it is desirable to dedicate a portion of the upstream conduit to storage. The dedicated portion is called an “approach pipe.” It is usually 75 mm to 150 mm (3 inches to 6 inches) larger than the conduit upstream of the dedicated portion, and it is laid at a compromise gradient of two percent (although other gradients could be used). At low liquid level, the velocity in the approach pipe is supercritical, thus leaving a large part of the cross section empty for storage as the liquid level rises. The design of approach pipes is not a part of the HI Standard, but the essentials of design are given in Appendix C.

Figure 6 (Standard Figure 9.8.3.2-1) shows the arrangement of an open trench wet well. The ogee spillway transition at the inlet to the wet well trench is designed to convert potential energy in the influent liquid to kinetic energy during the wet well cleaning cycle. The curvature at the top of the spillway should follow the trajectory of a free, horizontal jet issuing from under the sluice gate, and discharging approximately 75 percent of the flowrate of the last pump. The radius of the curvature, r , shall be at least 2.3 times the pressure head upstream of the sluice gate during cleaning. The radius of curvature at the bottom of the ogee need be large enough only for a smooth transition to horizontal flow; $0.5 r$ to $1.0 r$ is sufficient.

To produce smooth flow down the ogee ramp and avoid standing waves, the discharge under the sluice gate should be uniform in depth across the $2D$ width of the trench. Either a short transition from a circular to a rectangular section, as shown in Figure 6 (Standard Figure 9.8.3.2-1), or a short rectangular recess in front of the sluice gate is recommended.

All bell-type pump inlets, except that farthest from the wet well inlet, shall be located $D/2$ above the floor of the wet well trench. The inlet for the pump farthest from the wet well inlet shall be located $D/4$ above the floor of the trench. The last pump is used during the cleaning cycle and it is positioned closer to the floor to allow it to run longer at low liquid levels before it loses prime (Figure 6, Standard Figures 9.8.3.2-1 and 9.8.3.2-3).

For pumps that may be sensitive to loss of prime (due to entrainment of air from surface vortices), the pump inlet can be lowered by $D/4$, provided the floor near the intake is lowered by the same amount. Figure 7 (Standard Figure 9.8.3.2-2) shows this arrangement.

Fin-type floor splitters aligned with the axis of the trench are required. They must be centered under the suction bells for all but the pump inlet farthest from the wet well entrance. A floor cone should be installed under the pump inlet farthest from the wet well inlet conduit or pipe, as shown in Figure 6 (Standard Figure 9.8.3.2-1).

An antirotation baffle at the last pump inlet, shown in Figure 6 (Standard Figure 9.8.3.2-1), is needed to ensure satisfactory performance during the cleaning cycle. The antirotation baffle should protrude toward the pump as far as practicable.

Cleaning Procedure for Trench-Type Wet Wells

Trench-type wet wells for solids bearing liquids can be cleaned readily, by stopping all pumps to store enough liquid for the cleaning process in the upstream conduit. When sufficient

liquid is available, flow into the wet well should be limited to approximately 75 percent of the flowrate of the last pump in the trench, by adjusting the sluice gate. The pumps are operated to lower the liquid level to a minimum, as rapidly as possible, such that the stored liquid volume is sufficient to complete the cleaning cycle. As the liquid level in the wet well falls, the liquid attains supercritical velocity as it flows down the ogee spillway, and a hydraulic jump is formed at the toe. As the hydraulic jump moves along the bottom of the trench, the jump and the swift currents entrain both the floating and settled solids, causing them to be pumped from the trench. As the hydraulic jump passes under each pump intake, the pump loses prime and must be stopped.

Figure 8 shows the cleaning procedure being demonstrated on an intake model at the various stages of the process.

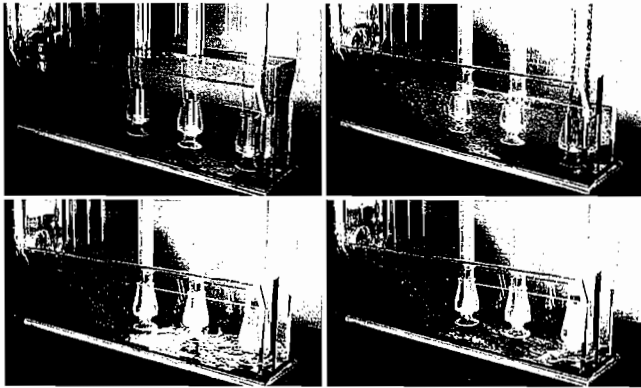

Figure 8. Trench-Type Wet Well During the Cleaning Procedure. (Courtesy Hydraulic Institute)

TRENCH-TYPE WET WELL DESIGN EXAMPLE

The following design criteria are known:

Wet well type	- Trench-type, per Figure 6 (Standard Figure 9.8.3.2-1)
Pumpage	- Raw municipal sewage
Station data	- 757 L/s (12,000 gpm) peak, inlet elevation of 30.5 m (100 ft) 189 L/s (3000 gpm) normal, inlet elevation of 29.5 m (96.8 ft) 63 L/s (1000 gpm) minimum, inlet elevation of 29.1 m (95.5 ft) 1.0 m (3.3 ft) square inlet, invert elevation of 29.0 m (95.1 ft)
Selected pumps	- Four vertical nonclog, rated 252 L/s (4000 gpm) each 56kW (75 hp) motor driver with variable frequency speed control 0.610 m (24.0 inch) suction bell diameter D 12.0 m (39.4 ft) NPSHR at runout, corrected to bottom of bell with a 1.0 m (3.3 ft) margin

Design Steps

1. Check maximum inlet velocity (must be less than 1.2 m/s (4 ft/s)).
 $V = 757/1000/(1.0 \times 1.0) = 0.757 \text{ m/s (2.5 ft/s)} \checkmark \text{ GOOD}$
2. Calculate elevation of the bottom of the trench.
Figure 6 (Standard Figure 9.8.3.2-1) shows dimensional requirements. Since the invert elevation of the inlet pipe is 29.0 m (95.1 ft), this can also be assumed to be the top elevation of the ogee and that the bottom of the trench will be no higher than:
 $29.0 - 2D - D/2 = 29.0 - 2.5 \times 0.610 = 27.47 \text{ m (90.1 ft)}$
maximum elevation
For this example, we will round down to an elevation of 27.4 m (89.9 ft).

3. Calculate width of trench at bottom:

$$\text{Width} = 2D = 2.0 \times 0.610 = 1.22 \text{ m (4.00 ft)}$$

For this example, we will round to a width of 1.2 m (3.9 ft).

We will also assume a side angle of 45 degrees above the trench, and a maximum width of 2.0 m (6.6 ft) at the top of the wet well.

4. Check maximum velocity in region above the trench (must be less than 0.3 m/s (1.0 ft/s) at all points of operation. At peak station flow of 757 L/s (12,000 gpm):

$$\text{Flow area} = 2.84 \text{ m}^2$$

$$V = 757/1000/(2.84) = 0.27 \text{ m/s (0.87 ft/s)} \checkmark \text{ GOOD}$$

At a normal station flow of 189 L/s (3000 gpm):

$$\text{Flow area} = 0.84 \text{ m}^2$$

$$V = 189/1000/(0.84) = 0.23 \text{ m/s (0.74 ft/s)} \checkmark \text{ GOOD}$$

At a minimal station flow of 63 L/s (1000 gpm):

$$\text{Flow area} = 0.13 \text{ m}^2$$

$$V = 63/1000/(0.13) = 0.48 \text{ m/s (1.59 ft/s)} \checkmark \text{ GOOD}$$

5. Calculate the minimum submergence above inlet bell entrance, S (same for the peak storm) and normal pump flowrate of 189 L/s (3000 gpm) per pump:

$$S = (1.0 + 2.3 F_D) D = [1.0 + 2.3 V/(gD)^{0.5}] D = D + Q/D^{1.5}/1069$$

$$S = 0.610 + 189/0.610^{1.5}/1069 = 0.981 \text{ m (3.22 ft)}$$

Note:

- A check of S versus NPSHR shows that the calculated minimum value of S would be adequate to meet the minimum NPSHR requirements.

- As shown in Figure 6 (Standard Figure 9.8.3.2-1), the minimum water level must be above the top of the ogee (to avoid a free fall entrance), and the top of the ogee must be a minimum of $2D$, or 1.22 m (4.0 ft), above the pump inlet. Therefore, the minimum S will be exceeded at all normal operational water levels. $\checkmark \text{ GOOD}$

6. Determine the radius " r " of the ogee ramp:

$$2D \leq r \leq 2.33 \times \text{Head on slice gate}$$

Since the normal station flowrate is 189 L/s (3000 gpm), and since this is 75 percent of a single pump's rated capacity, the cleaning cycle can be accomplished without throttling of the sluice gate. Therefore:

$$r \geq 2D = 2 \times 0.610 = 1.22 \text{ m (4.00 ft)}$$

The radius at the bottom of the ogee ramp will also be set to 1.22 m (4.00 ft).

7. Determine spacing between pump centerlines:

Spacing between pumps $\geq 2.5D = 2.5 \times 0.610 = 1.53 \text{ m (5.0 ft)}$ minimum. This is rounded up to 1.6 m (5.25 ft), and this dimension is verified by checking:

- For adequate room for equipment installation and accessibility.
- For free and safe movement of plant personnel.
- With the motor vendor to confirm spacing of motors to allow for proper ventilation.
- That the 0.75 m (2.46 ft) thick floor will provide a foundation with a mass greater than five times the mass of the pumping equipment—required to provide a foundation with adequate mass and stiffness to support the pumps without undue vibration.

8. The first pump will be located such that its centerline will be $0.5D$ from the bottom end of the ogee ramp.

9. The last pump will be located $0.75D$ from the end of the trench.

10. Check to see if a model test is required:

No model test will be required since the dimensions are in accordance with the HI Standard, the individual pump flowrate is less than 2520 L/s (40,000 gpm), and the total station flowrate is less than 6310 L/s (100,000 gpm).

The design is now complete. A layout with the dimensions calculated above is shown in Figure 9.

BIBLIOGRAPHY

“Hydraulic Institute Intake Design Standard 9.8” is available from the Hydraulic Institute, 9 Sylvan Way, Parsippany, New Jersey 07054-3802, Phone: 973-267-9700, Fax: 973-267-9055.

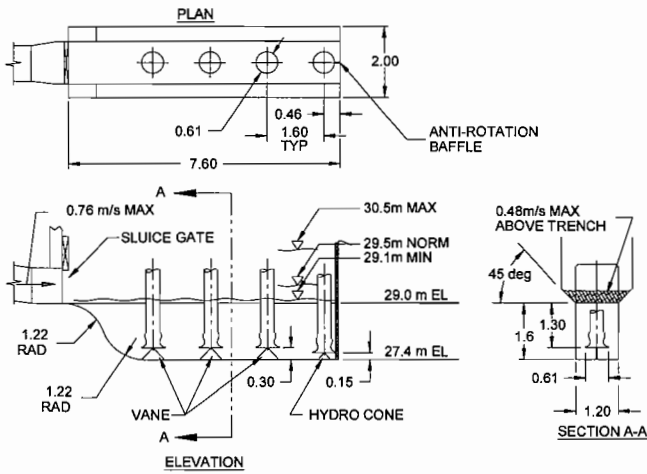

Figure 9. Completed Trench-Type Design Example. (Courtesy Hydraulic Institute)

APPENDIX

Note: This flow chart is intended as a guide to the use of this standard and can be used to locate the appropriate sections. The chart is not a substitute for the understanding of the complete standard.

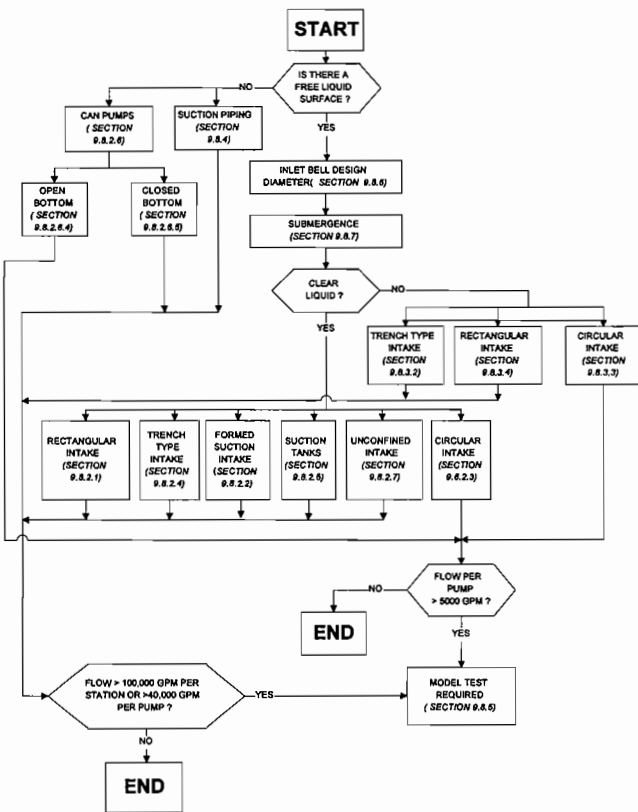

Figure A-1. Flow Chart for Use of Standard. (Courtesy Hydraulic Institute)