

SHAFT ALIGNMENT

by

Jack Essinger

Consulting Engineer

Acculign, Inc.

Willis, Texas



Advisory Committee.

Jack Essinger is a Consulting Engineer with Acculign, Inc., in Willis, Texas. He holds a B.S. degree (Mechanical Engineering) from Arizona State University, and worked as a machinery engineer for Shell Oil Company for 29 years. He founded Acculign, Inc., in 1973, and is a registered Professional Engineer in the State of Texas. He has served on a number of API Committees, and is a Member Emeritus of the Turbomachinery Symposium

EQUIPMENT DESIGN

To achieve proper alignment, it is essential that the equipment has been designed and built to facilitate the procedure. In many cases, standard design of the equipment is adequate. In other cases, the required features are mandated by standards such as those of the American Petroleum Institute. There remain many machines, however, that are not covered by appropriate standards or specifications, and it is left to the user to see that the designs are appropriate. Mandatory items in this regard include the following:

- *Allowable Forces and Moments.* For equipment to which piping will be attached, it is important that the design be capable of absorbing reasonable forces and moments that will be exerted by the piping. Regardless of the adequacy of the piping design and installation, some forces and moments will result and must be handled by the equipment. Adequacy of design involves not only the rotating equipment itself, but the associated baseplates and/or soleplates. They must be of adequate strength, well made, and designed to facilitate grouting.

- *Couplings.* Couplings must be of proper design and with adequate spacer length to accommodate normal misalignment, including startup, shutdown, and off-design conditions. Adequate spacer length is one of the most important design features in realizing good alignment.

- *Lifting Provisions.* Provisions must be made for moving the equipment vertically and horizontally during the final alignment procedure. For equipment of small to moderate size, jackscrews may be adequate. Large machines will likely require something more elaborate, such as provisions for hydraulic jacking equipment.

- *Provisions for Turning the Shafts.* It is normally a requirement to turn equipment shafts during the final alignment procedure. For small machines, this is of little concern—they can easily be turned by hand. For larger equipment, however, it is sometimes very difficult to find a way to rotate the shafts. Such provisions, including special tools, if required, should be part of the initial design.

- *Machined Supports.* Machine supports and the mating soleplates or baseplate pads must be machined flat and coplanar. Additionally, the soleplates or baseplates must be sufficiently rigid to resist warpage during handling and installation, and must be designed to facilitate grouting. While these appear to be obvious requirements, they are included here because of the number of industrial machines that are not so manufactured.

- *Placement of Auxiliaries.* Placement of instrumentation, junction boxes, lube and seal oil piping, conduit, tubing, and auxiliaries must be such that they do not interfere with the alignment process. Moreover, they must not restrict lifting or lateral movement of the equipment, removal or placement of shims, or installation and rotation of alignment brackets. Achievement of these goals normally requires constant vigilance on the

ABSTRACT

Proper alignment of rotating equipment has long been recognized as a prerequisite to safe, reliable operation. Achieving proper alignment, however, involves much more than merely adjusting the machines so that the shafts are coaxial. It involves the design and implementation of the equipment and of the system into which the equipment is integrated. Important issues in design and implementation of the entire system are highlighted, along with details of the final alignment process.

INTRODUCTION

Virtually every user of rotating equipment recognizes that the safety and reliability of that equipment is greatly influenced by the alignment of the shafts. Improperly aligned equipment, even if well designed, properly installed, and correctly operated, will fail prematurely. With this knowledge, users are generally conscientious in aligning such equipment prior to operation.

The emphasis on alignment, however, is often focused solely upon the final adjustments of the equipment after installation and prior to startup. While this final adjustment is a vital part of the overall procedure, it is not the entire procedure. For the alignment to be successful, both the equipment and the overall system must be properly designed, and the installation must be well done.

Important items that must be done prior to the final alignment adjustment are highlighted, along with some details of the final alignment procedure. General recommendations for alignment tolerances are also presented.

THE OBJECT OF ALIGNMENT

The object of equipment alignment is to assure that the coupled shafts are properly aligned under all operating conditions, and that they remain so aligned throughout the required running period of the machines. By proper alignment, it is meant that the shafts are coaxial, within tolerance, and that the axial shaft separation is within tolerance.

part of the user during design, manufacture, and installation of the equipment.

- *Tilting Pad Bearings.* For equipment with tilting pad bearings, orientation is an important alignment feature. With a load-on-pad design, Figure 1 (A), the shaft is free to move laterally within bearing clearance, and alignment data are difficult to obtain without temporary bearing shims to stabilize the shaft. With a load-between-pad design, Figure 1 (B), the shaft remains stable during the alignment procedure. This arrangement also makes internal clearance checks within the equipment much easier and more reliable.

While a load-on-pad design may occasionally be required by rotordynamics considerations, load-between-pads can usually be supplied without compromise. Ask for it.

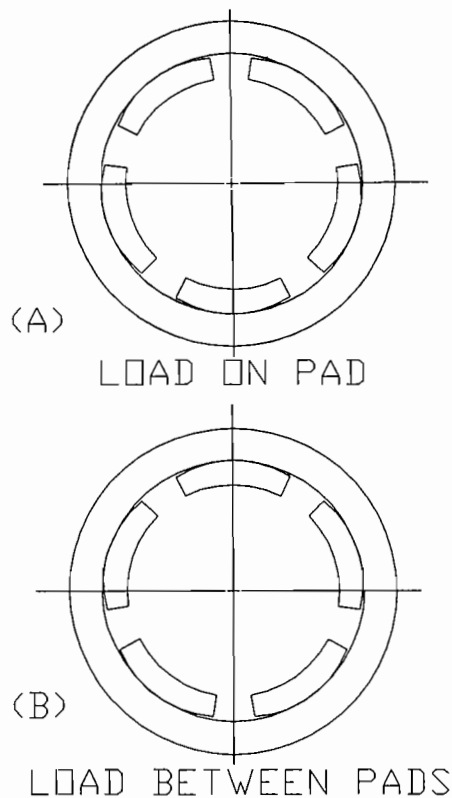

Figure 1. Tilting Pad Bearing Configurations.

THE EQUIPMENT SYSTEM

As with the equipment itself, the system into which the machines are incorporated has a pronounced effect upon the ability to achieve and maintain proper alignment. For those involved in the design of systems that include rotating equipment, it is vital that these items be considered from the conceptual stages. For those doing final alignment adjustments after installation, it is important that checks be made to assure that the system is installed as designed, and that design features have not deteriorated. The following items are important.

Piping

It is generally accepted that improperly-designed or poorly-fitted process piping is one of the major causes of shaft misalignment and other mechanical failures. The insidious nature of the piping problems also make them among the most difficult to

find, analyze, and treat. Except in rare cases, it is not possible to determine by visual inspection whether or not a problem exists or to evaluate its severity.

While piping system design and/or analysis are outside the scope of this presentation, the subject is of such vital importance to proper alignment that some precautionary comments are warranted.

- *Mechanical Design.* Aside from hydraulic considerations, piping design must include a mechanical layout that will permit proper support, guidance, and restraint of the piping. Additionally, an analysis is required to assure that the piping is not overstressed during installation and operation, and that it does not impose undue forces and moments on the mechanical equipment to which it is attached.

Historically, the hydraulic and stress calculations were done using very simple calculations and empirical data. The mechanical layout would involve a plan to minimize loading on rotating equipment by using adequate pipe loops to give flexibility, and by the judicious placement of supports, guides, and restraints.

The advent of computers, however, has had a dramatic affect upon piping design, with much more emphasis on analysis and much less emphasis on basics. The results are mixed. On the one hand, the computer routines offer a means for doing a much more thorough analysis than can possibly be done manually. In this regard, computer-designed piping can be a blessing. There is, on the other hand, a growing tendency to rely solely upon the computer analysis of a piping system without regard to basic good practice of system layout. In these cases, computer-designed piping can be disastrous. An effective system will include fundamental practices of good layout and a reasonable computer analysis.

- *An Overall Plan.* In designing piping that connects to rotating equipment, it is absolutely essential that the designer have an *overall plan* for the piping system. Prior to any detailed analysis, the designer must study the application and make some judgments as to what is required. If the piping is to operate at elevated temperatures, for example, the designer must recognize that pipe loops will very likely be required to accommodate thermal growth, and such loops must be incorporated in the initial layout. The configuration of the piping loops will likely change when a detailed piping analysis is done, but at least the piping loops with which to work will be there.

Similarly, especially if the piping is large or heavy-walled, it must be recognized that substantial anchors will be required to accommodate piping forces, and the piping must be routed through locations where it is possible to locate such anchors, i.e., at grade level. Forces caused by thermal growth of large piping can be enormous, and generally cannot be handled adequately in overhead structures.

Once an overall plan is established to accommodate hydraulic forces, thermal growth, and the support of pipe, pipe fittings, and contents, then the computer can be used to refine and optimize the system and the piping will turn out well. To do a computer analysis on a system that has no overall plan, however, is an invitation to disaster. Such a system simply will not meet expectations.

- *The Computer Analysis.* It is imperative that the computer model adequately depicts the system being studied. In this regard, be aware that all computer models are *not* the same, nor will all analysts make the same assumptions when using a given computer model. Many times, the analyst may choose to use only a portion of the capabilities of the analytical program, and omission of critical details may have a pronounced affect upon the results of the study. It is common practice, for example, to

support piping by welding a steel shoe to the pipe, and having this shoe rest directly upon a steel cross member of a pipe rack. The weight of the pipe and contents is supported by the steel plates, but the pipe is considered to be free to move in lateral directions. Free to move, that is, if enough force is exerted to overcome friction, rust, and paint at the support location. For small piping, it may be appropriate to assume that this arrangement is "frictionless," and to treat it in that manner in the analytical model. For large piping, however, the assumption of no friction is grossly inadequate, and a reasonable friction factor must be assigned. Better yet, use pipe hangers instead of shoes when lateral movement is expected; hangers are inherently flexible in the lateral direction.

Similarly, it is often assumed that pipe anchors are totally rigid, i.e., that they do not move regardless of the piping force applied. While this may be a reasonable assumption for small piping anchored to a large concrete foundation, it is certainly not true for large piping anchored in a structural steel system well above grade. Some very dire piping problems have arisen from this specific erroneous assumptions.

In short, there are many assumptions that must be made when using a computer model. Be sure the assumptions are appropriate. Some additional items that should be considered are:

- Apply a safety factor to allowable forces and moments on rotating equipment. Safety factors are used routinely in mechanical design to account for unknowns and uncertainties. Piping design has plenty of both, and a safety factor of not less than two is recommended. If the calculated forces and moments are no more than one half of the allowable, then the actual forces and moments ultimately may be within limits. Without a safety factor, actual forces and moments are certain to exceed the allowables.

- Make allowances for system deterioration. Differential settlement of foundations is a fact of life, and should be assessed in the analysis. It is very common, for example, for a pump and driver to be supported on a monolithic concrete block whereas the piping to the pump is supported from an adjacent concrete slab. Differential settlement is a virtual certainty. Similarly, if the main pump and spare pump are on separate foundations, any common manifolding of piping should consider differential settlement of the two pumps.

- Analyze any off-design conditions such as startup, shutdown, or steamout, especially if the rotating equipment will be running during these conditions.

- Account for thermal movements of the rotating equipment itself.

- For liquid-filled systems, be sure the weight of the liquid is considered.

- *Additional Items.* Aside from layout and analysis, a number of additional items are worthy of mention:

- *Expansion Joints.* In general, the use of expansion joints is to be discouraged, but they sometimes represent the only reasonable solution to certain flexibility problems. Properly used, expansion joints can be very useful in accommodating large movements in piping systems. When used improperly, however, they can present some serious problems.

The most common error with expansion joints is in trying to accommodate thermal growth in a piping system by compressing the expansion joint (Figure 2 (A)). In pressurized systems, hydraulic forces within the expansion joint itself try to push the connecting piping away in both directions. These axial forces must be counteracted by tie rods, gimbal joints, or by anchors

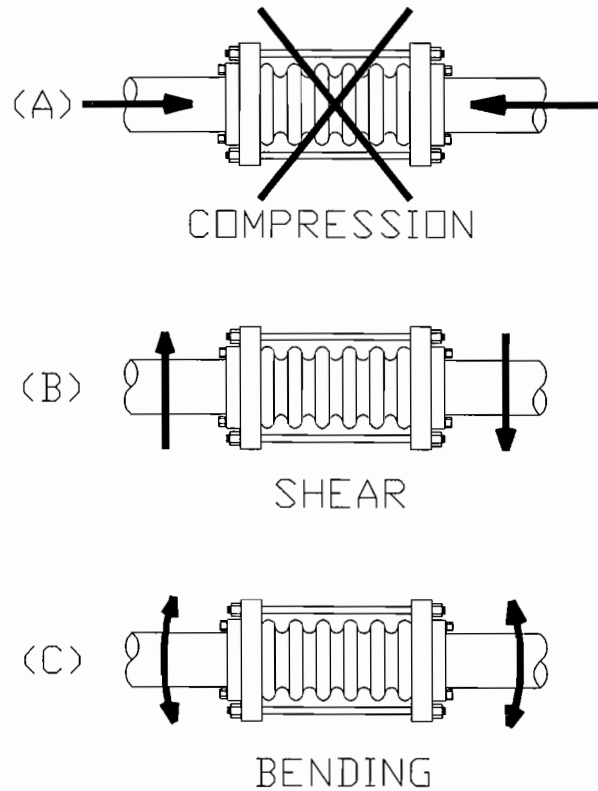

Figure 2. Typical Methods for Using Expansion Joints.

within the piping system. The magnitude of the axial force is dependent upon the size of the expansion joint and the pressure within the system, and can be very high, even in systems operating at moderate pressures. A 12 in unrestrained expansion joint operating at 100 psi, for example, will exert about 14,000 lb axial force on the piping system. Similarly, very large axial forces can be generated in vacuum systems using large diameter expansion joints.

When they are required, it is generally much preferred to use expansion joints in shear or bending (Figure 2 (B) and (C)).

- *Rigid Pipe Supports.* Rigid supports are generally a poor choice for supporting piping near rotating equipment. Inherently, a rigid support cannot accommodate even small thermal changes in the piping or the equipment itself without affecting the forces and moments on the rotating equipment, and these affects can sometimes be very large. This is easy to see, for example, on the inlet piping to a steam turbine. If the support is adjusted to handle the weight of the piping in the cold condition, it will be totally ineffective as soon as the turbine warms up and rises a few thousandth of an inch. If it is adjusted to support the pipe in the hot condition, it will produce a large force on the turbine when the system is cool. Similar analyses apply to virtually all other equipment as well. Spring supports are very much preferred under such conditions, since they can accommodate piping and equipment movements with only minor changes in supporting force.

Despite the overall advantages of spring supports, it should be noted that they are not without problems of their own. Specifically, spring supports present some unique installation/alignment problems when they are used to support large, liquid-filled piping where the weight of the fluid in the piping may be much greater than the weight of the piping itself.

As furnished, a spring support normally has a temporary "stop" that compresses the spring to the calculated service condition, i.e., to the point where the spring is expected to be compressed when supporting the pipe and its contents. The intent is that the stop be left in place until the piping is installed and made up to the rotating equipment, after which the system will be filled with liquid and the stop removed. Problems arise, however, if the stop is removed prematurely (before the pipe is filled with liquid), or during maintenance when the stop may not be reinstalled before liquid is drained from the system. Care must be exercised to see that the spring support and the stop are properly used.

- *Make Up to Rotating Equipment.* On initial installation, or if the piping or equipment has been removed for maintenance, it is important to assure that the final make up of flanges to rotating equipment is properly done. Most users have a specification covering the maximum allowable equipment movement resulting from piping make up, and it is generally a requirement that a mechanical inspector or craftsman witness the piping installation.

Typically, dial indicators are used to monitor vertical and horizontal shaft movement as the piping is being installed. These dial indicators are sometimes mounted on the brackets that will ultimately be used for alignment of the equipment, or they may be mounted from the baseplate.

Allowable tolerances vary among users, but normally run in the range of 0.002 in to 0.003 in total indicator reading as the maximum allowed. If the equipment moves more than the allowable tolerance during piping make up, corrective action must be taken.

- *Piping System Inspection.* Aside from the actual fit-up of piping to the rotating equipment, it is important to see that the entire piping system is complete and functional before the actual alignment procedure is started. This check should include the following:

- Is all piping properly made up with gaskets and all flange bolts tightened?
- Are hydrotests done and slip blinds removed?
- Are all pipe guides, supports, and restraints in place and in good condition?
- Is the piping system liquid-filled (very important for large piping)?
- Are spring supports adjusted and within the proper operating range? Are stops removed? (See previous discussion under *Rigid Pipe Supports*).
- Is all auxiliary piping made up (even small piping can affect alignment)?
- Is piping insulation completed?

Supporting Structure

Prior to the actual alignment procedure, it is essential that the supporting structure of the equipment be inspected to assure that it is in good working order. While a semblance of alignment may be achieved with a flawed supporting structure, the long term results will certainly be less than expected. Proper alignment cannot be achieved unless the equipment is properly supported.

While details of this inspection may vary greatly depending upon the design of the actual equipment, the following items should be observed:

- *Concrete Foundations.* Concrete foundations should be checked for general deterioration including cracks, sloughing, exposed reinforcing steel, oil-soaking, or evidence of founda-

tion settlement. If such problems appear, they should be evaluated and corrected as necessary. Be especially mindful of installations where the two pieces of equipment to be aligned rest upon separate foundations, or where major auxiliary equipment such as the condenser for a steam turbine is on a foundation not integral with that of the turbine. With such arrangements, differential settlement of foundations may cause very serious alignment problems even though the individual foundations may be in excellent condition.

- *Structural Steel Supports.* For equipment mounted on structural steel, the supporting structure should be inspected for deterioration such as rust, welding cracks, damaged structural members, and missing fasteners. Be alert to any field modifications that may have altered the characteristics of the original installation. Significant field welding and/or flame cutting can cause serious distortions not only to the supporting structure, but to the rotating equipment mounted upon it.

Be aware of the routing of hot piping in and around the structure. Uninsulated or poorly-insulated steam lines, for example, can cause significant structural distortion that may affect equipment alignment. Be aware, also, that lubricating oil and seal oil tanks built into the steel structure may be sources of alignment problems, especially for equipment mounted on or directly above the oil reservoir. While it is not always feasible to eliminate these potential sources of distortion, except in the initial equipment design, the knowledge that they exist should alert the user to monitor the equipment closely.

Grouting

Once placed, it is often difficult to judge the quality of grouting. A visual inspection should be done, however, to assure that the grout is complete and in apparently-good condition. Items of concern include cracking, crumbling, voids, apparent-looseness, and oil-soaking. If any of these problems exist, corrective action should be taken.

Foundation Bolts

Foundation bolts must be tight. Once installed and properly tightened, foundation bolts should never become loose under normal operating conditions. If loose foundation bolts are found, investigate and correct the cause. Such looseness may be caused by grout deterioration, rusting, foundation bolt yielding, or other causes. Whatever the cause, it is not advisable merely to retighten the bolts without further investigation.

Shims and Hold-Down Bolts

Shims and hold-down bolts are vital links between the machine and the foundation. It is important that every shimpack and hold-down bolt in the equipment train be checked, not just the ones on machines that are to be moved to achieve alignment. Typically, this inspection is done one shim location at a time. Remove the hold-down bolt and raise the equipment sufficiently to remove and inspect all shims at that location. The following recommendations are offered:

- *Hold-Down Bolts.* Clean, inspect, and lubricate the hold-down bolt. Assure that the bolts are of the proper length, i.e., long enough to assure a minimum thread engagement approximately equal to the bolt diameter, but short enough so as not to "bottom-out" when tightened. At the same time, assure that the equipment is not "bolt-bound," i.e., that there is sufficient room for lateral movement of the equipment to achieve alignment. To assure room for lateral movement, some users require that a spacer be installed around the hold-down bolts during initial installation and initial alignment. The spacer is removed prior to

final alignment, thereby assuring that the hold-down bolt is reasonably centered in the bolt hole.

While most specifications prohibit undercutting of bolts to achieve lateral movements, it is sometimes the only practical solution once the equipment is installed. If undercutting must be done, bolt diameter should never be reduced to less than the diameter at the thread root. Care must be exercised to assure that undue stress risers are not introduced during undercutting. Adequate mechanical inspection during initial equipment installation will eliminate the problem altogether.

- **Washers.** Assure that washers on the hold-down bolts are in good condition and that they are heavy enough so as not to distort when the bolts are tightened. In many cases, standard flat washers are inadequate for this service, and special heavy-duty washers may be required. Two-piece spherical washer sets (equalizing washers) are sometimes very useful. These commercially available washers are much more resistant to distortion than are standard washers.

- **Shimpacks.** Shims must be of materials that do not corrode or rust in a normal plant environment. Brass shimstock has been conventional for many years, but stainless steel shimstock is currently preferred by most users, and is a requirement of some specifications, including those of the American Petroleum Institute (API). Moreover, precut shims are now widely used on small to moderate-sized equipment and are generally recommended because of their uniformity and ease of use. Most users also feel that they are cost effective.

- Use as few shims as possible. It is much better to use a few shims of greater thickness than to use many thin shims. Even with uniform shims of high quality, the more shims that are used, the harder it is to get full compression. Many company specifications limit the number of shims that can be used. A maximum of five or six shims is typical. Some companies also require one relatively thick (1/8 in) shim at each location to assure that it is possible to make a relatively large vertical movement of either machine, should that become necessary. Many times, this thick shim has proved to be very valuable when an "identical" spare or replacement machine is installed and is found to have a shaft centerline elevation different from the original.

Conversely, many users prohibit the use of extremely thin shims because they are difficult to handle, and can easily become folded or wrinkled at installation. Typically, there is no need to use shims thinner than 0.002 in. In the final shim "sandwich," place thicker shims top and bottom, with thinner shims in the middle.

- Assure that the shims are clean, of uniform size, and free of hammer marks, wrinkles, and burrs. Equally important, see that the mounting surfaces of the equipment and the baseplate/soleplate are clean, free of rust, and in generally good condition.

Use shims of an appropriate size. Shims that are too small will not adequately support the equipment. Shims that are too large cannot be properly compacted by the hold-down bolts. For most equipment, the size of the shims will approximate the size of the machine support. Notable exceptions are some electric motors that have a continuous supports for the full length of the motor. The manufacturer of such equipment should be consulted for specific recommendations. Generally, however, shim such equipment only at hold-down bolt locations.

- It is typical of the design of some large machines that one or more of the supports remain free to move laterally and/or axially during operation to compensate for thermal movements of the equipment. For such machines, inclusion of a shim of

glass-reinforced Teflon has proved useful in assuring low-friction movement.

- **Parallelism of Supports.** Check for parallelism of the machine supports and the corresponding surfaces on the baseplate/soleplate. A visual inspection will reveal gross problems. A feeler gauge inspection is more precise. With the machine resting upon the shims, but not tightened down, assure that a feeler gauge of approximately 0.002 in cannot be inserted between the machine support and the shims. If the feeler gauge can be inserted at some locations on a support but not at others, it is an indication of nonparallelism of support surfaces.

If the nonparallelism of supports is excessive, it may present a problem that is not easily solved, especially when relatively large equipment is of concern. It is one of the problems that should have been detected and corrected at initial installation, but such is not always the case. The solution may require remachining of the equipment supports or baseplate/soleplate, regrouting, or both. Tapered shimpacks are sometimes used as an expedient, but are seldom a satisfactory long-term solution. Once again, the presence of a good mechanical inspector during installation would have eliminated the problem.

- **Bolt Tightening.** Tighten all hold-down bolts to the prescribed torque value. Use good practice in tightening the bolts; i.e., tighten bolts sequentially to about 60 percent of the final torque value, then 80 percent, then 100 percent.

Casing Distortion (Soft Foot)

Aside from parallelism of the support surfaces, it is also vital that the correct thickness of shimpack be used at each location to assure that the equipment is not distorted when the hold-down bolts are tightened. This check for distortion is normally referred to as a *Soft Foot Check*. Details depend upon the size and type of equipment to be checked as noted below:

- **Small Equipment.** For equipment with torsionally-rigid casings (such as most API and ANSI process pumps and their drivers), it is customary to conduct the soft foot check at each machine support. This check is usually done immediately following the installation of shimpacks and the tightening of hold-down bolts. To do this check, mount a dial indicator on the baseplate with the indicator stem resting atop the equipment support (Figure 3). A magnetic base is very handy for this check, but it must be substantial and must be rock-solid to assure good readings. Loosen the hold-down bolt at that location, and note the amount of rise of the support. If the support moves more than about 0.002 in, it is an indication that the casing is being distorted, and that additional shims are required at that location. Conversely, if there is no movement at all when the bolt is loosened, it may be an indication that there are too many shims at that location. Add or remove shims as required, and repeat the

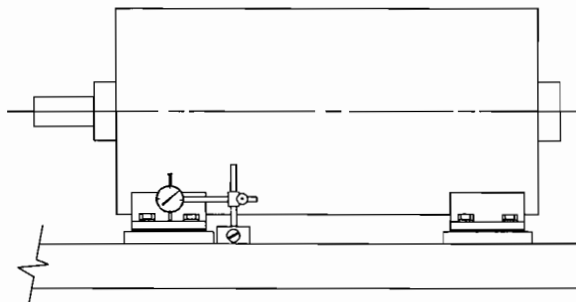

Figure 3. Dial Indicator Arrangement for Distortion (Soft Foot) Check.

procedure at each machine support until the desired results are obtained. When properly shimmed, the support movement at each location should be approximately equal.

Remember, this is a check for *casing distortion*. It is vital to the good mechanical health of the equipment, and it must be conducted on each piece of rotating equipment in the train (see precautions for gears, below).

- *Moderate-Sized Equipment.* For larger pieces of equipment where the casings are not as torsionally-rigid (moderate-sized centrifugal compressors and condensing steam turbines, for example), provisions for field-verification of casing distortion should be included in the design. Many options are available. Optical targets can be provided that can be checked during factory assembly and rechecked in the field. Alternatively, specially-machined flats for precision levels can be supplied at several locations on the equipment. For horizontally-split machines, these flats can be provided merely by extending the lower flange out about two inches further than the upper flange. These flats have proved to be very useful in detecting twisted casings during installation.

For machines having four support locations, and for which no checking provisions have been made during manufacture, a relatively simple test for gross distortion can be done as follows: With three supports tightened down, remove the shimpack from the fourth support. Measure and record the thickness of the shimpack. Remove the temporary support at this location. Using feeler gauges, measure and record the gap between the machine support and the baseplate/soleplate. Subtract the feeler gauge dimension from the shimpack thickness. This is the total deflection of the machine casing at that location with no support. Reinstall the shims, then repeat the procedure at each of the other three support locations. Compare results. Differences larger than about ten percent at any of the four supports may be an indication that the casing is distorted as-shimmed.

- *Large Equipment.* For very large equipment (large centrifugal compressors, for example), yet other techniques must be employed. If specific provisions have not been included in the design, it may be necessary to partially dismantle the equipment to check for distortion. Discuss the issue with the technical representative of the equipment manufacturer.

- *Equipment with Gearing.* For equipment trains employing gearing, extraordinary precautions are required with regard to setting the gear case and aligning the gearing. Only with very small, low-speed gearing is the normal soft foot check applicable. For virtually all other gearing, acceptance criteria must be based upon gear tooth contact and not upon casing distortion. In some instances, it may actually be necessary to introduce slight casing distortion in order to get proper tooth contact.

In virtually all cases, the recommended procedure is to install the gearcase, assuring that proper gear contact has been achieved, and then align other equipment to the gear. Do not move the gearcase once it has been installed and proper tooth contact verified.

EQUIPMENT SURVEY

In addition to assuring that the system is complete and ready for the alignment process, it is equally important to determine that the rotating equipment itself is ready. While this admonition may seem trite and unwarranted, it is made on the basis of experience to the contrary. It is not uncommon for alignment attempts to be made on equipment that is simply not ready to be aligned.

It should be noted that the alignment procedure is likely to be slightly different for equipment that is being installed for the

first time, and equipment that is being aligned during normal maintenance. For new equipment, alignment is nearly always done before any significant piping is bolted-up to the equipment, and the alignment is then monitored as the piping is fitted. This is an important step in assuring that the piping does not impose undue stresses upon the rotating equipment in the cold condition.

For equipment that has been in service, however, alignment checks are often done with the piping connected. While some would argue that the piping should be unbolted for alignment rechecks, that may be neither practical or desirable. If the machine has no history of alignment problems, and if the recheck reveals that the alignment is satisfactory or that only small corrections are required, then there is really little reason to remove the piping. If, on the other hand, the machine has a history of abnormal maintenance and reliability problems, and/or if pipe strain is suspected, then it is probably worth the effort to remove piping prior to the alignment recheck. The user must make the decision on a case by case basis.

Among the items that should always be verified before final alignment are the following:

- See that the machines to be aligned are totally assembled including seals, bearings, and small auxiliary piping. Disengage seal locks, if used.

- Assure that the shafts of both machines rotate freely. With pressure-lubricated systems, it is good practice to circulate lubricating oil during the alignment process.

- Inspect the coupling to assure that it is complete, clean, and in overall good condition. Pay particular attention to the flexible elements of the coupling to assure that they are not damaged. Also inspect coupling bolts and nuts to assure that they are the right size and that they are clean and well lubricated. For high speed couplings, assure that the bolts and nuts are from weight-matched sets.

If the coupling hubs have not been installed, see that shaft extensions are clean, free of rust and burrs, and that the diameters are within tolerance. Check shafts for runout. Typically, shaft runout should be well under 0.0005 in. Similarly, check coupling bore dimensions. Assure that all items are clean and free of burrs.

See that keys (if used) are of proper size and length, and that they fit the keyways properly. After installation of the coupling hubs and keys, check the runout of the outside diameter of the hubs as well as the face. For fully-machined couplings, these runouts are typically on the order of 0.001 in, although some users specifications may allow as much as 0.002 in on low speed applications. For general-purpose couplings that are not fully machined, runouts may be considerably higher.

SELECTING AN ALIGNMENT SEQUENCE

During the early stages of the alignment procedure, it is necessary to determine which machine is to be moved to improve alignment. If only two machines are involved, the decision is usually fairly easy. With motor-driven pumps, for example, it is virtually universal that the motor would be moved. First and foremost, the motor does not have process piping to worry about. Secondly, it is just plain easier to move a motor than to move most pumps.

As the equipment becomes more complex, however, so does the selection process. If the process pump is driven by a steam turbine rather than an electric motor, then the decision may not be so clear. In this case, both machines have piping with which to contend, and the decision must be made on other factors. If the pump is simple and operates at ambient temperature, it would probably be logical to move the pump. If it is a multistage pump

handling a hot product, then it may be easier to move the turbine. If you can't decide, it probably makes no difference.

While all rules in this regard are flexible, the following are generally followed:

- Move motors instead of other equipment.
- Move driven equipment instead of steam turbines.
- Move equipment with no process piping if possible.
- Move equipment that operates at ambient temperature rather than equipment that operates at elevated or reduced temperatures.
 - *Use special care if a gear is involved.* Gears require special care to assure that alignment of the gear mesh is proper. Once the gear is properly installed, do not move it. In virtually every case, the gear should be installed and other equipment should be aligned to the gear.
- For long equipment trains, it is sometimes useful to start near the middle and align both ways. In all cases, it is essential to do a preliminary (rough) alignment on the entire train before doing the final alignment at any coupling. The consequences of omitting the rough alignment step is obvious; if there is no room to move the last machine in the train, you start over.

SELECTING AN ALIGNMENT METHOD

The term "alignment method" refers to the method used to determine the relative position of the machines to be aligned. Most commonly used conventional methods use mechanical dial indicators as the primary measuring tool, although micrometer methods are useful for some types of couplings. Additionally, specialized laser alignment systems are available and are fairly widely used.

The specific method to be used in any alignment situation is dictated by a number of factors such as the type and size of the machines being aligned, the type of coupling, the availability of alignment tools, the training and experience of the craftsmen, and the specifications of the user. For this study, however, only conventional alignment methods will be discussed, and only the two most common methods will be treated in detail, i.e., the *Face and Rim Method* and the *Reverse Indicator Method*.

The Face and Rim Method

For this well-known and widely used method (Figure 4), an alignment bracket is attached to one of the machine shafts (or coupling hub) and extends to the proximity of the coupling hub on the other machine. Dial indicators are affixed to the bracket, as shown, with the stem of one indicator resting upon the face of

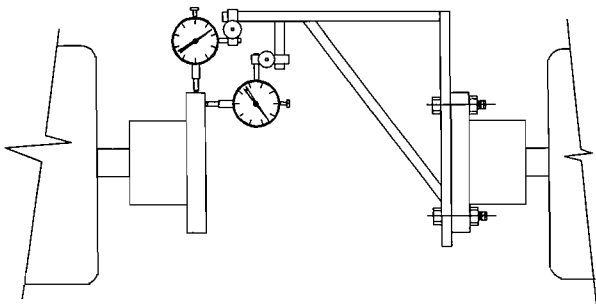

Figure 4. Face and Rim Method. Typical bracket and dial indicator arrangement.

the hub, and the stem of the other indicator resting upon the outer diameter (the rim) of the same coupling hub.

To determine the relative shaft alignment of the two machines, it is customary to null (zero) the dial indicators at the uppermost (top) position, and then to rotate both shafts in 90 degree increments, so as to get a complete "set" of dial indicator readings at the top, both sides, and the bottom positions. Data from the dial indicator reading on the rim are used to determine the relative radial position of the shaft centerlines in the plane of this dial indicator. Dial indicator readings on the face of the coupling hub reveal the angularity of the two shafts. Using these data and the machine dimensions, the user can determine the shim changes and horizontal movements required to achieve proper alignment. Details are included in following sections.

Advantages of this method include.

- The method is intuitive, simple, well-known, and easily understood.
- It normally works well when coupling spacers are short and hub diameters are large.

Disadvantages of this method include.

- Accuracy is lost if hub diameters are small.
- Face readings are affected by axial movement (float) in either or both shafts.
- Typically, the coupling spacer must be removed.
- Data may be affected by inaccurate coupling geometry.

Use of this method is generally discouraged for high-speed, high-horsepower equipment, for couplings having long spacers, for couplings having small diameter hubs, or for equipment where shafts may have axial movement. It should be noted that equipment using antifriction bearings may still have some axial float, although it is generally not sufficient to cause a problem.

Reverse Indicator Method

The Reverse Indicator Method is shown in Figure 5. The origin of this method is obscure, but it is known to have been used to a limited degree for many years. Over the past two decades, however, the method has become very popular and is considered by many users to be inherently more accurate and reliable than the Face and Rim Method.

With this method, alignment brackets are secured to the shaft or to the rigid coupling hub of one machine, and extend over the coupling spacer to the rigid hub (Figure 5 (A)), or to the alignment bracket (Figure 5 (B)) of the other machine. Dial indicator readings are taken in the radial direction only—no face readings. As with other methods, it is customary to "zero" the dial indicators at the uppermost (top) position, and then rotate both shafts in 90 degree increments so as to get a complete "set" of readings at the top, both sides, and at the bottom. Data from these dial readings yield information regarding the relative offset of the shaft centerlines in the planes of the two dial indicators. Using these data and machine dimensions, the user can determine the shim changes and horizontal movements required to achieve proper alignment. Again, details are given in following sections.

Advantages of this method include:

- The coupling spacer need not be removed.
- Data are more accurate if coupling spacers are long.
- Data are more accurate if coupling hubs diameters are small.
- Readings are essentially unaffected by axial shaft movements.

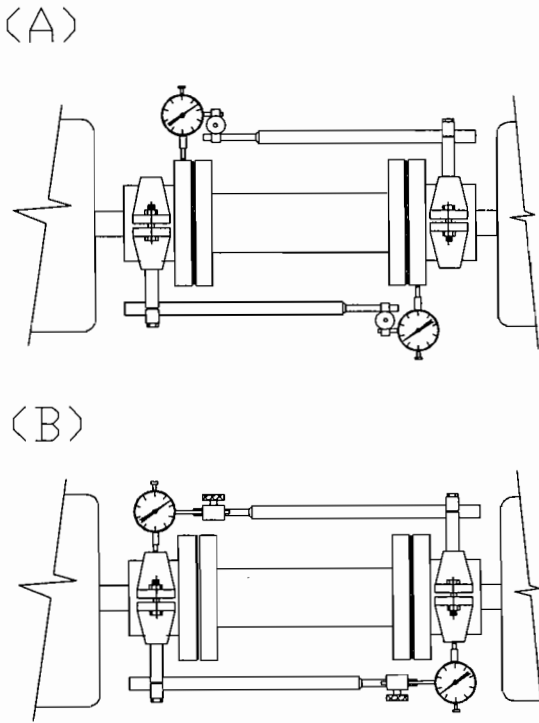

Figure 5. Reverse Indicator Method. Typical bracket and dial indicator arrangement.

Disadvantages of this method include:

- Limited access to shafts may make brackets difficult to fit.
- The method is generally not suitable for couplings with very short spacers.
- For most people, interpretation of the data is not intuitive.

This method is normally recommended for high-speed, high-horsepower equipment, and is especially applicable to couplings with long spacers and small diameter hubs. The method should not be used, however, unless there is a reasonable distance between the planes of the two dial indicators. If this distance is too short, the ability to determine angular misalignment will be diminished; it is the corollary to the problems associated with a small diameter hub when using the face and rim method. As a general rule, this method should not be used if the distance between dial indicators is less than the diameter of the hub upon which face readings would be taken.

ALIGNMENT TOLERANCES

Sources for Tolerance Recommendations

Unfortunately, there are no universal standards for alignment tolerances. While recommendations exist from a number of sources, there is little general agreement on what such tolerances should be, or how they should be measured. Some sources of such information are:

- **Coupling Manufacturer's Data.** Virtually all coupling manufacturers publish recommendations concerning the maximum misalignment to which their couplings should be subjected. For standard production couplings, these ratings are normally listed in the manufacturer's catalog or in published technical bulletins. For special, high-performance couplings, the maximum allowable misalignment is normally shown on the coupling drawing.

The misalignment ratings vary greatly depending upon the type and size of coupling, and upon the specific manufacturer. Generally speaking, however, the manufacturer's allowable misalignment has to do with the capabilities of the coupling itself as opposed to considerations of the coupled equipment. In most cases, the misalignment allowed by the manufacturer far exceeds the misalignment that would be allowed by the user.

- **Textbooks, Reference Books, and Technical Papers.** Specific recommendations are given in a number of excellent technical publications on coupling alignment, such as *Total Alignment* by V. R. Dodd, and *The Shaft Alignment Handbook* by John Piotrowski. Typically, these recommendations are based upon user consensus, as modified by the individual experiences of the authors. While the recommendations vary in detail, they generally reflect allowable tolerances that will assure trouble-free operation of a wide variety of rotating equipment. Readers are urged to review the referenced publications.

- **User Specifications.** Many user companies have developed alignment specifications that reflect allowable tolerances. These specifications are usually drawn from experiences within the company, and normally reflect the consensus of technical personnel within the organization. Readers may wish to avail themselves of such inhouse specifications.

- **PIP/API RP686.** This recommended practice for machinery installation remains unpublished at the time of this writing, but is certain to contain recommended alignment tolerances.

Precautions in Applying Specifications

Important factors that should be considered when applying alignment tolerances include criticality of equipment, rpm, horsepower, coupling type, and coupling spacer length. Vital equipment, high rpm, and high horsepower usually demand closer alignment tolerances than do routine, low-rpm, low-horsepower machines. Coupling type and spacer length also play important roles. Other things being equal, machines with longer coupling spacers are more tolerant of misalignment than are those equipped with short spacers. The specific type of coupling also plays a role, but is generally of less importance than is spacer length.

Specifications for alignment tolerances should recognize and incorporate these factors, and should be established so as to assure adequate and consistent alignment for the application without being over-restrictive. Moreover, the specification should be simple, easily-measured, and easily-monitored. Unfortunately, it is seldom easy to meet all these criteria, and many of the commonly used specifications lean toward the side of simplicity. Some examples are as follows:

- **Dial Indicator Readings.** An often used acceptance criterion for misalignment is merely a maximum allowable dial indicator reading. A typical specification may read "Maximum allowable dial indicator readings shall not exceed 0.004 in TIR (total indicator reading) for equipment operating 1,800 rpm or less, and 0.002 in TIR for equipment operating in excess of 1,800 rpm." While the specification addresses equipment rpm as an important criterion, it does not address the method by which data are to be taken, nor does it consider coupling geometry, both of which are vital.

The appeal of such a specification is its simplicity. It is easy to understand and to monitor. Beyond the simplicity, however, such a specification is of little value. It assures neither proper alignment nor uniformity. Such specifications should be discouraged.

Please refer to Figure 6, which depicts machines being aligned by the Face and Rim Method. As is typical with alignment measurements, dial indicator readings are shown in mils (1.0 mil

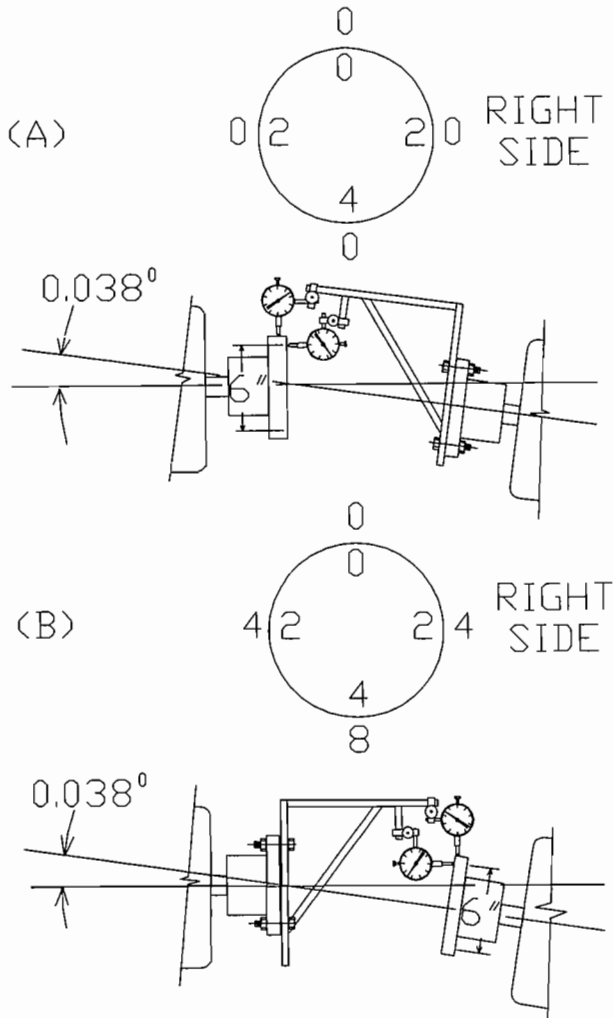

Figure 6. Face and Rim Method. Inconsistencies when applying simplified acceptance criteria.

= 0.001 in). Indicator readings on the rim of the coupling are shown on the outside of the circle; face readings are shown on the inside of the circle. The right-hand side of the equipment train is identified.

Assuming that the alignment criterion is a maximum indicator reading of 0.004 in, the alignment of the machines in Figure 6 (A) would be satisfactory. Now refer to Figure 6 (B), where the dial indicator bracket has been reversed to read on the opposite machine. While the relative position of the two machines remains unchanged, the readings now show the alignment to be unsatisfactory. The inconsistency is readily apparent, as is the unsuitability of the simple acceptance criterion.

Next, please refer to Figure 7 for machines being aligned by the *Reverse Indicator Method*. When using this method, it is customary to present the dial indicator readings on the outside of two separate circles as shown. The right-hand side of the equipment train is designed by the "R" in the circle. Again, the readings are in mils.

Using the same acceptance criterion of 0.004 in maximum dial indicator reading, the alignment of the equipment in both cases is satisfactory. The dial indicator readings are, in fact, identical. Note, however, that the angular misalignment of the coupling in Figure 7 (B) is twice as great as in Figure 7 (A) because the length of the coupling spacer differs. Again, the inconsistencies

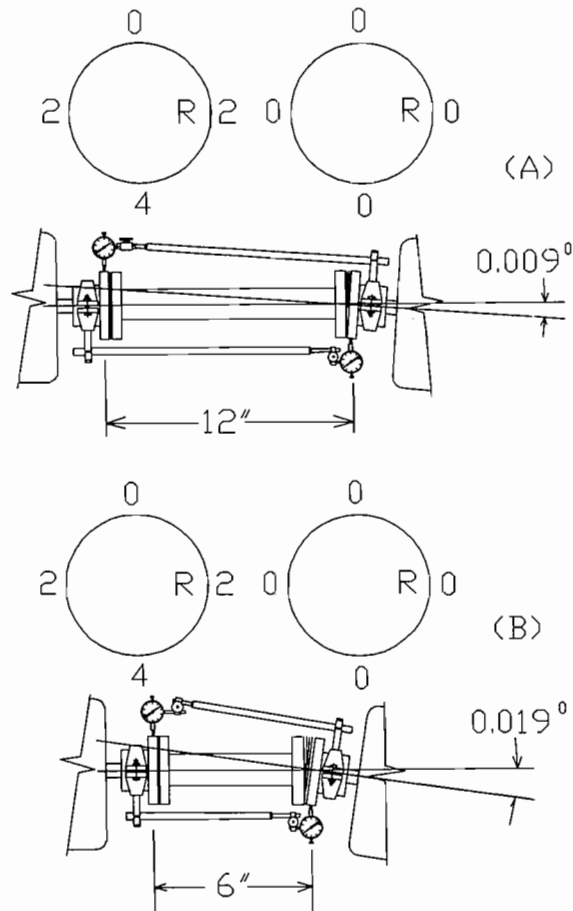

Figure 7. Reverse Indicator Method. Inconsistencies when applying simplified acceptance criteria.

are evident. Consistent acceptance criteria simply cannot be based solely upon dial indicator readings.

• *Offset and Angularity*. Another relatively common specification places limits upon what is called parallel offset and angularity. Such a specification may read, for example, "Maximum allowable misalignment shall not exceed 0.004 in total indicator reading, plus 0.002 in per foot angularity."

This specification is relatively easy to understand and implement when using the *Face and Rim Alignment Method*, as shown in Figure 8. The parallel offset is determined from the rim reading (actual offset is one half of the dial indicator difference). Angularity is determined from the face readings. While the specification is probably very poor, it is understandable.

When other alignment methods are used, however, such as the *Reverse Indicator Method*, it is much more difficult to understand and to implement. Specifically, the so-called *parallel offset* is vague, at best, and becomes meaningful only if further defined in some manner. Except when used with the Face and Rim Method, this type of specification is not only poor, but is also vague.

Recommendations

First, it is the recommendation of the author that industry rethink the continued use of the term *parallel offset* when establishing alignment criteria. While the term has some meaning when dealing with the *Face and Rim Method*, it is largely meaningless and very confusing when dealing with other meth-

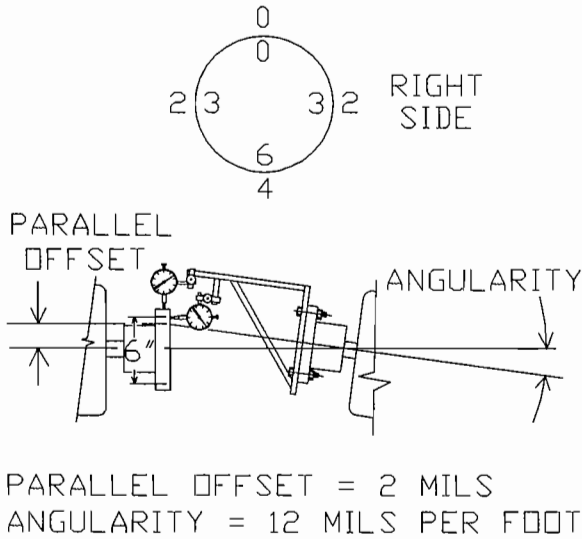

Figure 8. Face and Rim Method. Definition of parallel offset and angularity.

ods. The sooner users rid themselves of the term, the quicker they will be able to write really meaningful alignment specifications.

Much more meaningful criteria can be established by considering the angularity of the coupling spacer with respect to each of the coupled shafts, and by tempering the acceptable angularity with items such as coupling type, rpm, horsepower, and criticality of application.

A spacer coupling accommodates shaft misalignment by angular deflection of the flexible elements (gears, discs, diaphragms, etc.). The amount of deflection is dependent upon the specific misalignment of the equipment, and the length of the coupling spacer. Please refer to Figure 9, which depicts misalignment of coupled machines in the vertical and horizontal planes.

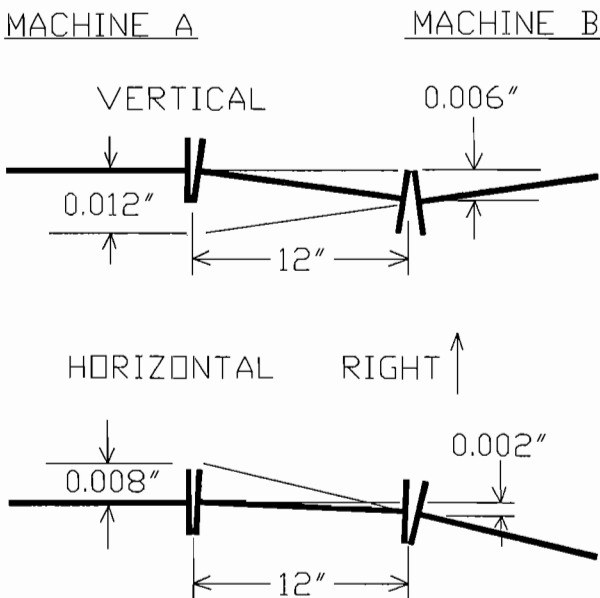

Figure 9. Misalignment of coupling spacer with respect to coupled shafts.

In this example, the coupling spacer length (the distance between flexible elements) is 12 in. Misalignment of the coupling spacer with respect machine A results from the vertical and horizontal offsets of the spacer at the plane of the flexible element at machine B. Misalignment of the coupling spacer with respect to machine B results from the vertical and horizontal offsets of the spacer at the plane of the flexible element at machine A.

Considering the misalignment of the coupling spacer with respect to machine A, it can be seen that the vertical component of misalignment is 0.006 in, and the horizontal component is 0.002 in. The total misalignment of the coupling spacer with respect to Machine A is $\sqrt{0.006 \text{ in}^2 + 0.002 \text{ in}^2} = 0.0063 \text{ in}$. The misalignment of the coupling spacer with respect to machine B is $\sqrt{0.012 \text{ in}^2 + 0.008 \text{ in}^2} = 0.0144 \text{ in}$.

It is most convenient to express spacer-to-shaft misalignment as a ratio of offset to spacer length. In this case, the controlling (largest) misalignment would be 0.0144 in for a 12 in spacer, or 0.0012 in/in of spacer length. If degrees of angularity are preferred, 0.0012 in/in of spacer length is 0.068 degrees.

Having determined the unit misalignment, the data can be compared to established acceptance criteria. As noted earlier, there are no universally recognized standards with which to compare data, but a review of data from various sources would suggest tolerances approximating those shown in Table 1. Please note that these recommendations are for the maximum misalignment of the coupling spacer with respect to either of the coupled shafts, and that they represent the resolved angularity, i.e., vertical plus horizontal.

Table 1. Recommended Alignment Tolerances. Alignment values reflect maximum resolved angularity of vertical plus horizontal offsets.

Maximum RPM	Maximum Angularity, Degrees	Maximum Unit Offset of Spacer Inches per Inch
1,800	0.086	0.0015
3,600	0.057	0.0010
10,000	0.043	0.00075

The user will probably wish to temper these data bases criticality of equipment, type of coupling, personal experience, etc. It is the experience of the author, that these tolerances are readily achievable, and generally quite conservative. It is highly unlikely that normal industrial equipment aligned to these tolerances will ever suffer misalignment problems, with the following possible exceptions:

- Equipment employing solid couplings may require closer tolerances.
- Equipment suffering from unusually sensitive rotordynamics.

While the recommended shaft-to-spacer criteria will yield better and more consistent results than will simpler criteria such as dial indicator readings, interpretation is slightly more difficult and involves some minimal calculations. As an aid in this regard, APPENDIX A is a Basic Language program listing that will do the calculations for both *Face and Rim* and *Reverse Indicator Methods*. APPENDIX B is a sample printout from this Basic Language program.

ALIGNMENT BRACKET REQUIREMENTS

General Requirements

Virtually all alignment methods using dial indicators require some type of bracket or brackets to affix the indicators to the equipment being aligned. Such brackets may be of a universal-type available from a number of manufacturers, or they may be fabricated specifically for one application. It is common to use commercially-available brackets for equipment of small to moderate size, and to use specially-designed brackets for large equipment.

Regardless of bracket details, they must be rigid, fit the equipment properly, be easy to use, and be in good mechanical condition. They must not damage shafts or couplings. Makeshift tools, brackets with excessive sag (see *Bracket Sag*), magnetic bases, and nonrepeatable tools should never be used.

A very simple test can tell a lot about the suitability of brackets. After the bracket is installed and the dial indicator zeroed, shake the assembly a few times—not enough to bend anything, but just enough to assure yourself that the everything is tight and that the dial indicator reading will return to zero. If the bracket fails this simple test, don't use it.

Bracket Sag

The deflection of a bracket due to its own weight and the weight of the dial indicators is referred to as bracket sag. With reasonable brackets, this deflection is too small to be readily visible, but is usually sufficient to cause significant errors in the dial indicator readings. To compensate for these inherent errors, bracket sag must be measured and accounted for in the alignment procedure. It is typical to measure sag in various brackets as follows:

- *Universal Brackets.* A typical arrangement for measuring sag in universal brackets is shown in Figure 10. The bracket is clamped to a rigid piece of pipe or barstock that is approximately the same diameter as the shaft or coupling upon which the bracket will be clamped in service. The dial indicator to be used in the alignment procedure is fastened to the bracket with the indicator stem resting upon the top of the pipe or barstock, and set to zero (Figure 10 (A)). The entire assembly is then rotated 180 degrees so that the indicator stem now reaches up to touch the pipe or bar (Figure 10 (B)). The dial indicator will now show

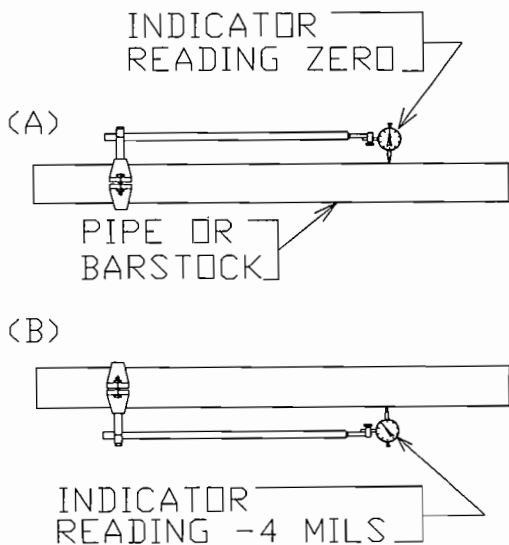

Figure 10. Sag Check for Universal Alignment Bracket.

a negative reading. The absolute value of this reading is known as the bracket sag. If, for example, the indicator is zeroed at the top and reads -0.004 in when the assembly is inverted, the bracket sag is said to be 0.004 in.

Since the deflection of the bracket is affected to some degree by the clamping arrangement, it is important the pipe or barstock being used is approximately the same diameter as the shaft or coupling to which it will be clamped in service. Severe deviations will likely affect the results.

- *Special Brackets.* The clamp of special brackets is normally bored to a specific diameter to fit the machine shaft or coupling hub (Figure 11). The method for determining sag in special brackets is identical to that for universal brackets except for a requirement that a mandrel be turned specifically to fit the bracket. Since this is a bracket made for a specific application, the amount of sag, once determined, should be permanently marked upon the bracket.

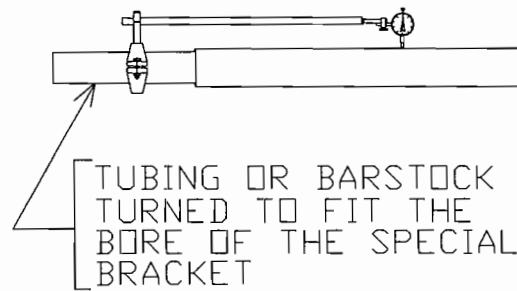

Figure 11. Sag Check for Special Purpose Alignment Bracket.

- *Face-Mounted Brackets.* Although reverse indicator brackets have become very popular in recent years, there are still applications that require face-mounted brackets, and there are still some who prefer this method, even on very large equipment. While the sag of well-made brackets of this type can be quite small, it is still essential that it be checked.

The normal method for checking such brackets is shown in Figure 12. After checking to see that the tailstock spindle is aligned with the headstock, the bracket is mounted in a lathe as shown, and turned about the tailstock spindle to check sag. The amount of sag should be permanently marked on the bracket for future reference.

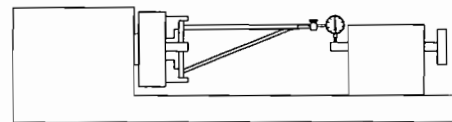

Figure 12. Sag Check for Face Mounted Alignment Bracket.

- *Quill Shafts.* There are a number of industrial machines such as centrifugal compressors for refrigeration services and small screw compressors that are driven through quill shafts rather than conventional flexible couplings. To achieve adequate flexibility to handle misalignment, these quill shafts tend to be long and of quite small diameter. Typically, they are flanged at one end and splined at the other. In aligning such equipment, it is customary to have the flanged end bolted-up to the equipment, and to fasten a dial indicator to the splined end to measure alignment to the adjacent machine.

By design, such shafts are very, very flexible. Most often, sag is significant and must be measured and accounted for. Please refer to Figure 13 for a typical arrangement for checking sag with this type of coupling.

• *Precaution:* It was stated earlier that brackets with excessive sag should not be used. Since sag must be measured and corrected in any event, the requirement for minimum sag is sometimes questioned. The reason for the requirement of minimal sag is one of repeatability of measurements. If the bracket is rigid (little sag), then any effects of friction and spring constant in the dial indicator are of very little concern. If the brackets are flexible, however, readings may be affected greatly by the characteristics of the dial indicator itself. Typically, good brackets will sag no more than 0.005 in to 0.010 in, although brackets for very long spans may exceed these figures. Brackets showing sag greatly exceeding these figures should be checked for repeatability of data.

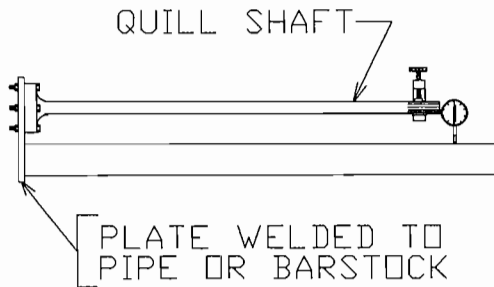

Figure 13. Sag Check for Quill Shafts.

TAKING AND RECORDING READINGS

Having completed the preliminary checks on the system and the equipment, it is time to take readings to determine the relative positions of the machines to be aligned. The general procedure is as follows:

• Secure or prepare the documents upon which alignment readings will be recorded as they are taken. The importance of this often ignored step cannot be overstated. A well designed, logical, and complete form is an invitation to take good alignment data. An ill-prepared form, or no form at all, is an invitation to errors, wasted time, and poor alignment.

Examples appear in Figures 14 and 15 of typical forms that may be used for routine equipment where thermal growth is expected in the vertical direction only, and where such growth is expected to be uniform, i.e., the same vertical growth at each end of the machine. The form must include spaces in which to record equipment identification, machine dimensions, expected thermal growth of each machine, bracket sag, coupling spacer length, date, a comment section, and a place for the signature of the craftsman taking the data. To avoid confusion, a different and specific form should be available for each type of alignment method that may be used.

For *vital equipment* such as large turbocompressor trains, thermal movement may be expected in both vertical and horizontal directions. Moreover, it is common that the thermal growth is nonuniform, i.e., different at each end of the equipment. For these situations, considerably more information is required. Typical of forms used to collect alignment data for vital equipment are depicted in Figures 16 and 17.

• Identify the right hand side of the equipment train. With all alignment work, proper orientation is mandatory and must remain constant throughout the alignment procedure. Although

ROUTINE EQUIPMENT

FACE & RIM

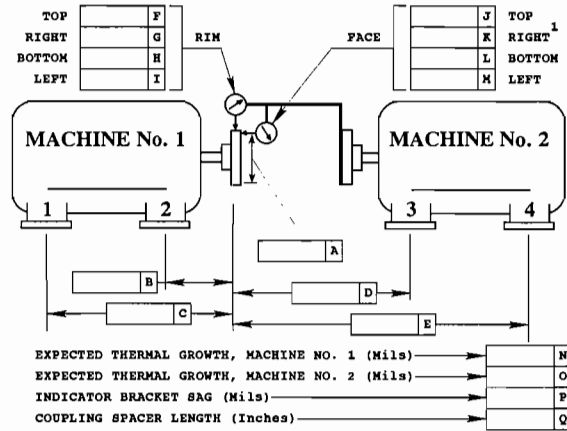

NOTE 1: RIGHT AND LEFT REFERS TO THE RIGHT AND LEFT HAND SIDES OF THE EQUIPMENT TRAIN. THE RIGHT HAND SIDE OF MACHINE NO. 1 IS ON THE SAME SIDE OF THE TRAIN AS THE RIGHT HAND SIDE OF MACHINE NO. 2.

USE THIS PORTION OF THE FORM FOR INSTRUCTIONS, SPECIFICATIONS, CALCULATIONS, ETC.

EQUIPMENT NO. _____ COMMENTS: _____
 DATE: _____
 BY: _____

Figure 14. Face and Rim Method Data Sheet for Routine Equipment.

ROUTINE EQUIPMENT

REVERSE-INDICATOR METHOD

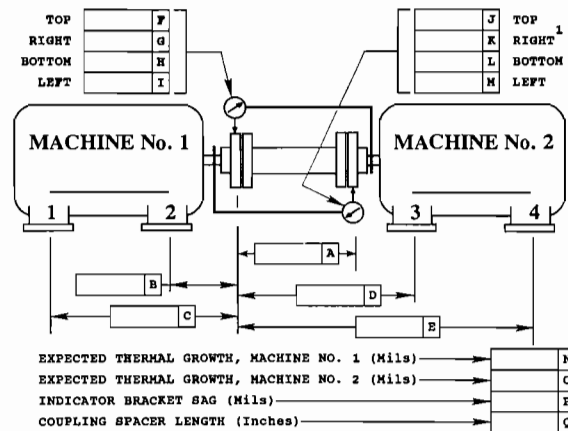

NOTE 1: RIGHT AND LEFT REFERS TO THE RIGHT AND LEFT HAND SIDES OF THE EQUIPMENT TRAIN. THE RIGHT HAND SIDE OF MACHINE NO. 1 IS ON THE SAME SIDE OF THE TRAIN AS THE RIGHT HAND SIDE OF MACHINE NO. 2.

USE THIS PORTION OF THE FORM FOR INSTRUCTIONS, SPECIFICATIONS, CALCULATIONS, ETC.

EQUIPMENT NO. _____ COMMENTS: _____
 DATE: _____
 BY: _____

Figure 15. Reverse Indicator Method Data Sheet for Routine Equipment.

VITAL EQUIPMENT

FACE & RIM

Note 1	TOP	F	RIM	K	TOP	Note 1
	RIGHT	G	FACE	L	RIGHT	
	BOTTOM	H	READINGS	M	BOTTOM	
	LEFT	I	BRACKET SAG	N	LEFT	
		J				

Vert.	O	Vert.	P	Note 2	Vert.	Q	Vert.	R
Horiz	S	Horiz	T	Note 3	Horiz	U	Horiz	V

NOTE 1: RIGHT AND LEFT REFERS TO THE RIGHT AND LEFT HAND SIDES OF THE EQUIPMENT TRAIN. THE RIGHT HAND SIDE OF MACHINE No. 1 IS ON THE SAME SIDE OF THE TRAIN AS THE RIGHT HAND SIDE OF MACHINE No. 2.
 NOTE 2: EXPECTED VERTICAL MOVEMENTS UPWARD ARE POSITIVE (+). DOWNWARD ARE NEGATIVE (-).
 NOTE 3: EXPECTED HORIZONTAL MOVEMENTS TO THE RIGHT ARE POSITIVE (+). TO THE LEFT ARE NEGATIVE (-).

USE THIS PORTION OF THE FORM FOR INSTRUCTIONS, SPECIFICATIONS, CALCULATIONS, ETC.

EQUIPMENT NO. _____ COMMENTS: _____
 DATE: _____
 BY: _____

Figure 16. Face and Rim Method Data Sheet for Vital Equipment.

VITAL EQUIPMENT

REVERSE-INDICATOR METHOD

Note 1	TOP	F	DIAL	K	TOP	Note 1
	RIGHT	G	READINGS	L	RIGHT	
	BOTTOM	H	BRACKET SAG	M	BOTTOM	
	LEFT	I		N	LEFT	
		J		O	BRACKET SAG	

Vert.	F	Vert.	Q	Note 2	Vert.	R	Vert.	S
Horiz	T	Horiz	U	Note 3	Horiz	V	Horiz	W

NOTE 1: RIGHT AND LEFT REFERS TO THE RIGHT AND LEFT HAND SIDES OF THE EQUIPMENT TRAIN. THE RIGHT HAND SIDE OF MACHINE No. 1 IS ON THE SAME SIDE OF THE TRAIN AS THE RIGHT HAND SIDE OF MACHINE No. 2.
 NOTE 2: EXPECTED VERTICAL MOVEMENTS UPWARD ARE POSITIVE (+). DOWNWARD ARE NEGATIVE (-).
 NOTE 3: EXPECTED HORIZONTAL MOVEMENTS TO THE RIGHT ARE POSITIVE (+). TO THE LEFT ARE NEGATIVE (-).

USE THIS PORTION OF THE FORM FOR INSTRUCTIONS, SPECIFICATIONS, CALCULATIONS, ETC.

EQUIPMENT NO. _____ COMMENTS: _____
 DATE: _____
 BY: _____

Figure 17. Reverse Indicator Method Data Sheet for Vital Equipment.

either side of the equipment train could be designated as the right hand side, it has become conventional to make the identification by viewing the equipment train from the driver end, and this convention is recommended.

- Install the alignment brackets and dial indicators. Assure that the indicators are in good working order (not sticking), that they are firmly secured to the brackets, that they are at mid-range, that the stems are reading on a clean, smooth surface, and that the stems are pointed directly at the shaft centerline.

After the brackets are installed and the dial indicators zeroed, shake the assembly to assure that it is tight and that the dial indicator reading returns to zero. If there are problems, fix them before taking any alignment data. Additionally, slip a thin shim of known thickness or a piece of paper under the stem of each dial indicator. The indicator should register the thickness of the shim, and should return to zero when the shim is removed.

Rotate the entire assembly two or three times to assure that there is no interference, that the shafts turn freely, that the dial indicators have sufficient range such that they do not “bottom-out” or lose contact at any point during the revolution, and that they return to their initial values.

Precaution: Dial indicators used in alignment work are always assumed to be direct-reading, i.e., that a positive reading is obtained when the indicator stem is pushed in. Also, pay particular attention to the markings on the indicator dial that may be either *continuous* or *balanced*. A continuous dial on a direct-reading indicator starts at zero and has continuously increasing numbers in a clockwise direction. A balanced dial, on the other hand, starts at zero and has continuously-increasing numbers in both directions. Either type can be used, and both types require equal vigilance to assure that proper readings are recorded.

- Rotate the shafts in the normal direction of rotation of the equipment until one of the dial indicators is resting at top dead center (tdc). Zero the indicator. Continue to rotate the shafts precisely 90 degrees until the dial indicator is horizontal. The reading will be positive (+) if the indicator pointer has rotated clockwise during the 90 degree rotation; it will be negative (-) if movement has been counterclockwise. Record the reading. It is conventional to record the reading in mils (1.0 mil = 0.001 in). Continue rotation until the dial indicator is at bottom dead center (bdc). Record the reading. Continue rotation another 90 degrees until the dial indicator is horizontal on the second side of the machine train. Record the reading. Continue rotation until the dial indicator is again at tdc. Check to see that the dial indicator returns to zero.

Now rotate the assembly until the second dial indicator is resting at tdc. Repeat the above procedure for the second indicator. Repeat the entire procedure a second time to assure accuracy and repeatability. It takes a short time to check the readings. It takes much longer to correct errors.

- While it is not a requirement to start the readings at tdc, it is normal to do so, and it is good practice. Establishing a routine for taking data is an aid in securing consistent results, and starting at tdc is can be part of an established routine.

- Please note that it is not essential that the dial indicators be zeroed at the start of readings, since it is the differential readings vertically and horizontally that are important. Again, however, it is part of an established routine and it is good practice to start at zero.

- Depending upon the brackets being used and the arrangement of the equipment, both dial indicators may or may not be at tdc simultaneously. One may be at tdc while the second is at bdc, or they may be arranged randomly. The specific arrange-

ment is of no concern so long as all readings include tdc and bdc positions.

Regardless of the arrangement, it is recommended that data from only one indicator be taken during one complete revolution of the equipment. While data can be taken from both indicators during one revolution of the shafts, it is the experience of the author that this practice is very likely to lead to errors in recording the data. Fewer errors will result if all data is taken from one dial indicator before taking any data from the second.

- Use care to assure that the shafts are stopped precisely at 90 degree increments. Four-point levels with a magnetic base are available for this specific purpose, and are a very worthwhile tool.

- Watch the indicators continuously as the shafts are being rotated. Be sure to determine if the dial has moved in a positive (+) or negative (-) direction, and be sure that the dial has not turned a full revolution without being detected.

- If the coupling spacer is removed (as with face and rim readings), it will be necessary to rotate both shafts independently while dial indicator readings are being taken, and precautions must be taken to assure that both shafts are rotated to the same relative position at each reading. This is best done by marking the places at which the dial indicator stems rest upon the equipment. Each time the shafts are rotated to another quadrant, these markings will assure that the shafts come to rest at the same relative position.

Precaution: Use care when taking alignment data on machines equipped with tilt pad journal bearings. Such bearings usually have an uneven number of pads (five is typical). If the pad arrangement is such that one of the pads is on bottom dead center (load on pad), then the shaft can rock horizontally, within bearing clearance, as the shafts are turned to get alignment data. It may be necessary to stabilize such bearings with temporary shims, or by some other means, while alignment data are being taken. If the design is such that one pad is top dead center, then the problem does not exist.

CHECKING AND CORRECTING READINGS

Having recorded consistent dial indicator readings, they must be checked for consistency and corrected for bracket sag. A typical set of dial indicator readings from a reverse indicator arrangement are shown at the top of Figure 18. The "R" in the circle reflects the reading taken on the right hand side of the equipment train. Readings are in mils.

- *Step 1—Check for Consistency.* For machines that are in relatively good alignment, a check for consistency can be made by summing the vertical readings (tdc plus bdc), and comparing that value to the sum of the horizontal readings (left-hand plus right-hand reading). For the readings at Machine A, the sum of the vertical readings is -28, as is the sum of the horizontal readings. For machine B, the sum of the vertical readings is 8.0, as is the sum of the horizontal readings. The readings are consistent.

This is a simple, but a very important check. When the absolute values of the dial indicator readings are small (say 20 or less), good readings will "add-up" within 1.0 mil. As the readings become larger, there is likely to be some deviation. Typically, however, the sum of the vertical and horizontal readings should deviate no more than about five percent of the largest single reading. If larger deviations exist, try to find the problem.

- *Step 2—Correct for Bracket Sag.* Bracket sag has a pronounced affect upon readings taken in a radial direction. When

STEP 1:

RECORD RAW READINGS AND CHECK FOR CONSISTENCY

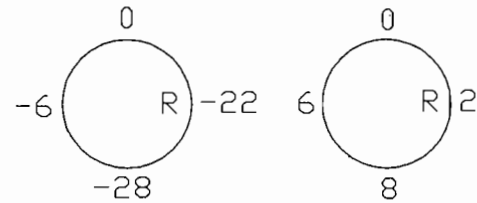

STEP 2:

CORRECT FOR BRACKET SAG OF 0.004". ADD 4 MILS TO EACH BOTTOM READING

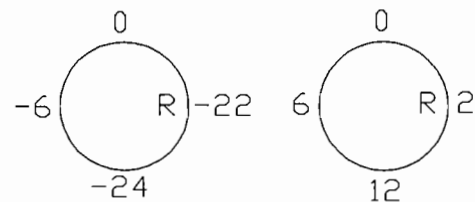

STEP 3 (OPTIONAL):

FOR EASE OF PLOTTING, MAKE ALL READINGS ZERO OR A POSITIVE NUMBER

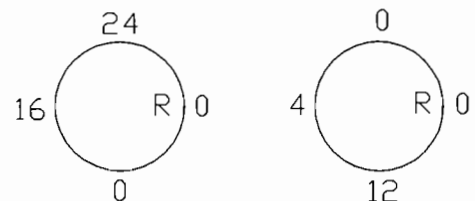

Figure 18. Dial Indicator Data Check and Corrections for Bracket Sag.

using the *Reverse Indicator Method*, this means that both sets of dial indicator readings must be corrected. When using the *Face and Rim Method*, only the rim readings will be corrected.

To correct for sag, merely add the absolute value of the bracket sag to the bottom dial indicator reading. For this example, the bracket sag is 4.0 mils. The corrected readings are as shown in the center for of Figure 18.

- *Step 3 (Optional)—Make all Readings Positive or Zero.* While this step is not mandatory, it is highly recommended, especially if the alignment of the equipment is to be determined by manual plotting. For most people, it is very much easier to deal with zeroes and positive numbers than to deal with a combination of positive and negative numbers.

To make this correction, each set of vertical and horizontal numbers can be handled individually. For Machine A, add 24 to each of the vertical readings, making the bottom reading zero, and the top reading 24. Add 22 to the horizontal readings, making the right-hand reading zero, and the left-hand reading 16. The vertical readings for Machine B are already zero and

positive, so no changes need be made. Horizontally at Machine B, deduct two from both readings, leaving a reading of four on the left-hand side, and zero on the right-hand side.

USING THE RESULTS

After the data have been collected, checked, and corrected for bracket sag, the results must be compared to the applicable alignment specification to see if alignment changes are required. If the alignment criteria is very simple (maximum indicator readings, for example), determination of acceptability is done merely by comparing readings to the specification. If other than very simple criteria is used, the comparison may require calculations, plotting, or a computer routine.

If the alignment is found to be acceptable, alignment tooling may be removed and the equipment made ready for service. After appropriate maintenance reports are completed and filed, the job is finished.

PLOTTING

If the alignment fails to meet the acceptance criteria, the data can be used to determine how the machines must be moved to bring them into compliance. This is best done by using a computer program, or by manual plotting. In reality, however, it is often done by trial and error—the most costly of all options.

Only the plotting option will be considered here. Four examples are presented, along with detailed plotting instructions for each example.

A typical plot is shown in Figure 19 of routine equipment aligned by the *Reverse Indicator Method*. A plot of the same equipment is shown in Figure 20 aligned by the *Face and Rim Method*. Routine equipment is defined as equipment where thermal movement is considered in the vertical direction only, and where such thermal movements are uniform along the length of the equipment.

A typical plot of vital equipment aligned by the *Reverse Indicator Method* is presented in Figure 21. A plot of the same equipment aligned by the *Face and Rim Method* is shown in Figure 22. Vital equipment is defined as equipment where thermal movements in both vertical and horizontal planes are considered, and where such movements are nonuniform along the length of the machines. Plots for vital equipment typically are more complex than for routine equipment, even though plotting procedures are essentially identical.

Precaution: When aligning equipment to parallel-shaft gears, it is important to recognize that gear forces will move both shafts to new locations within the bearings when power is applied. In most cases, these movements should be considered when aligning the equipment.

Similarly, it may be important to consider shaft movement within bearing clearances when aligning very high speed equipment, or equipment with very large bearing clearances. If the equipment has noncontacting vibration probes, gap voltage can be most useful in determining journal movements within the bearing.

MOVING THE MACHINES

Alignment changes, when required, are accomplished by adding or deleting shims, and/or by moving one of the machines laterally until the desired cold alignment is realized. Typically, this is a fairly straightforward procedure if appropriate tools are on hand to accomplish the task. The following general suggestions are offered:

- Check the dial indicator data and plots carefully before making any machine movements. It takes little time to check the data. It takes much more time to redo improper moves.

- If one of the required movements is significantly larger than the others, make the largest required movement first. This single move will make a significant improvement in alignment of the equipment, and will improve the accuracy of subsequent alignment data sets. If no single required movement is much greater than the others, then make alignment corrections first at the supports furthest from the coupling. Since coupling alignment is less affected by the position of the outboard support, it is less likely that subsequent moves will be required at that location.

It should be noted that some craftsmen prefer to make vertical movements before making horizontal movements. Others prefer to make horizontal movements before making vertical movements. In reality, it makes little difference, and the decision is best made on the basis of the greatest movement required.

- When making shim changes, loosen only the support where the change is to be made. Snug the bolt down after the shim change.

- When making lateral movements, it is normally good practice to leave one hold-down bolt tight, and to rotate the machine around that bolt. Typically, a dial indicator with a magnetic base is used to monitor horizontal movements at the support location where the movements are being made. Some craftsmen, however, prefer to monitor horizontal movements by using the dial indicators on the alignment brackets.

A word of caution is appropriate at this point. The supports on many machines, especially on larger equipment, are relatively flexible laterally and may not move in unison; i.e., when one support is moved laterally, the support on the opposite side of the machine may move a lesser amount, or may not move at all. For such machines, it is necessary to monitor the movement of both supports as lateral movements are made.

- **Important.** Keep tabs on shaft separation as the alignment work progresses. Machines have a way of getting moved axially during the alignment process and it is very difficult to make a final axial adjustment without adversely affecting radial alignment.

Make one move at a time, then recheck and update the dial indicator readings. Again, it normally takes much less time to check the data than to correct an improper move.

- Consider the job completed when the alignment criteria has been met. Inordinate amounts of unnecessary time and money can be wasted “trying to get things a little better.”

- Be wary of alignment moves that “do not go right.” For properly installed equipment, alignment moves are very predictable. If the equipment does not come into alignment as predicted, look for a problem such as pipe strain, casing distortion, improper shims, bolt binding, etc.

- Make one last check of hold-down bolt torque after proper alignment is achieved.

- Take a final set of dial indicator readings for the files, and be sure that complete data is included, i.e., final dial indicator readings, right/left orientation identified, dimensions shown, plus any pertinent comments for the next person doing the job. Date the data sheet, sign it, and get it into the file!

THE HOT CHECK

As noted earlier, the ultimate objective of the alignment exercise is to assure that shaft alignment is acceptable under all operating (hot) conditions, and that the equipment will remain properly aligned for an acceptable length of time. The purpose of the hot check is to verify alignment in the running condition.

Figure 19. Reverse Indicator Method Plot for Routine Equipment.

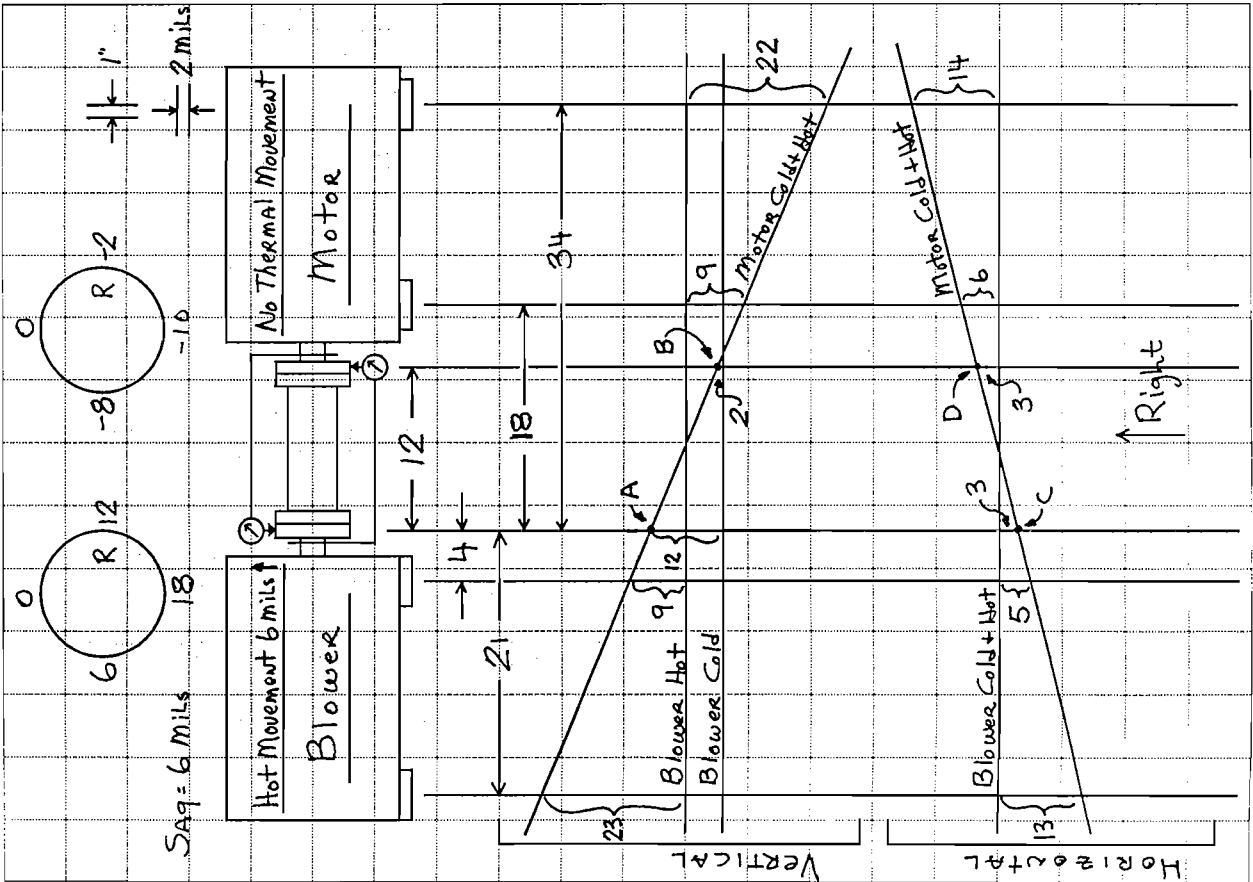

Plotting Instructions
Reverse Indicator Alignment - Routine Equipment
(Figure 19)

- Prepare a scaled plot of the equipment to be aligned. To enhance accuracy, make the plot as large as possible (11 in x 17 in minimum is preferred). Choose a scale that will maximize the size of the plot, and use care in laying out dimensions. Usefulness of results depend upon the accuracy of the plot. For this plot, the scale is 1 inch per division horizontally, 2 mils per division vertically.
- Correct the dial indicator readings for sag and for ease of plotting.

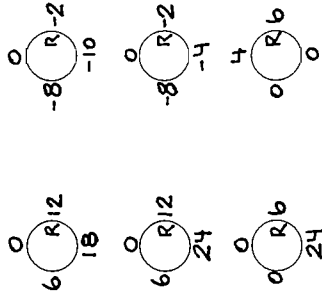

- Step 1: Raw Readings:
- Step 2: Correct for sag by adding the sag (6 mils) to the bottom reading.
- Step 3 (Optional): Convert readings to zero or positive numbers to assist in plotting.

- Draw a horizontal line on the graph to represent the vertical position of one of the machines in the "cold" condition. This line may represent either machine, but for this example it will represent the blower, and it is labeled "Blower Cold". Next, using the scale of two mils per division, draw a parallel line 6 mils above the original line. This line, labeled "Blower Hot", represents the blower in the hot condition; i.e., after the machine has grown 6 mils in the vertical direction.
- In a similar manner, draw a line representing the horizontal position of the same machine (the blower). Since horizontal thermal movement is not considered for routine equipment, this line represents both the "cold" and "hot" condition, and is so labeled. Identify the right-hand side of the machinery train.
- Referring to the corrected dial indicator readings above, locate points "A" and "B" through which the motor shaft must pass. Point "A" is located 12 mils above the centerline of the shaft of the blower in the cold condition (one half of the dial indicator reading). Point "B" is located 2 mils above the centerline of the blower shaft in the cold condition. A line passing through points "A" and "B" represents the motor shaft centerline in the cold condition. Since the motor is assumed to have no thermal movement, this is also the "hot" line. This line is labeled "Motor Cold & Hot".
- Similarly, locate points "C" and "D" in the horizontal plane. Point "C" is 3 mils to the left of the blower centerline. Point "D" is 3 mils to the right of the blower centerline. A line through these points represents the horizontal position of the motor shaft relative to the blower shaft. It is labeled "Motor Cold & Hot".
- Using the chosen scale, determine vertical and horizontal movements required to improve alignment. Assuming that the motor is to be moved, the inboard support should be raised 9 mils, and moved 6 mils to the left. The motor should be raised 22 mils at the outboard support, and moved 14 mils to the left. Similar information is available for moving the blower should that be desired.

Plotting Instructions
Face and Rim Alignment - Routine Equipment
 (Figure 20)

- Prepare a scaled plot of the equipment to be aligned. To enhance accuracy, make the plot as large as possible (11 in x 17 in minimum is preferred). Choose a scale that will maximize the size of the plot, and use care in laying out dimensions. Usefulness of results depend upon the accuracy of the plot. For this plot, the scale is 1 inch per division horizontally; 2 mills per division vertically.
- Correct the dial indicator readings for sag and for ease of plotting.

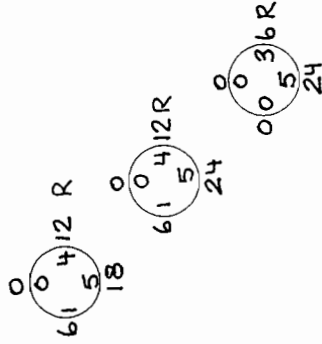

Step 1: Raw Readings:

Step 2: Correct for sag by adding the sag (6 mills) to the bottom rim reading only.

Step 3 (Optional): Convert readings to zero or positive numbers to assist in plotting.

- Draw a horizontal line on the graph to represent the vertical position of one of the machines in the "cold" condition. This line may represent either machine, but for this example it will represent the blower, and it is labeled "Blower Cold". Next, using the scale of two mills per division, draw a parallel line 6 mills above the original line. This line, labeled "Blower Hot", represents the blower in the hot condition, i.e., after the machine has grown 6 mills in the vertical direction.
- In a similar manner, draw a line representing the horizontal position of the same machine (the blower). Since horizontal thermal movement is not considered for routine equipment, this line represents both the "cold" and "hot" condition, and is so labeled. Identify the right-hand side of the machinery train.
- Referring to the corrected dial indicator readings above, locate point "A" through which the motor shaft must pass. Point "A" is located 12 mills above the centerline of the shaft of the blower in the cold condition (one half of the dial indicator reading). From inspection of the face readings, it is ascertained that the motor slopes downward from point "A" at an angle of 5 mills per 6 inch hub diameter. A line drawn through point "A" at an angle of 5 mills per 6 inch (10 mills per foot) represents the motor shaft centerline in the cold condition. Since the motor is assumed to have no thermal movement, this is also the "hot" line. This line is labeled "Motor Cold & Hot".
- Similarly, locate point "B" in the horizontal plane. Point "B" is 3 mills to the left of the blower centerline. Inspection of the face readings indicate that the motor slopes to the right from point "B" at an angle of 3 mills per 6 inch face diameter. A line drawn through point "B" at an angle of 3 mills per 6 inches (6 mills per foot) represents the horizontal position of the motor shaft relative to the blower shaft. It is labeled "Motor Cold & Hot".
- Using the chosen scale, determine vertical and horizontal movements required to improve alignment. Assuming that the motor is to be moved, the inboard support should be raised 9 mills, and moved 6 mills to the left. The motor should be raised 22 mills at the outboard support, and moved 14 mills to the left. Similar information is available for moving the blower should that be desired.

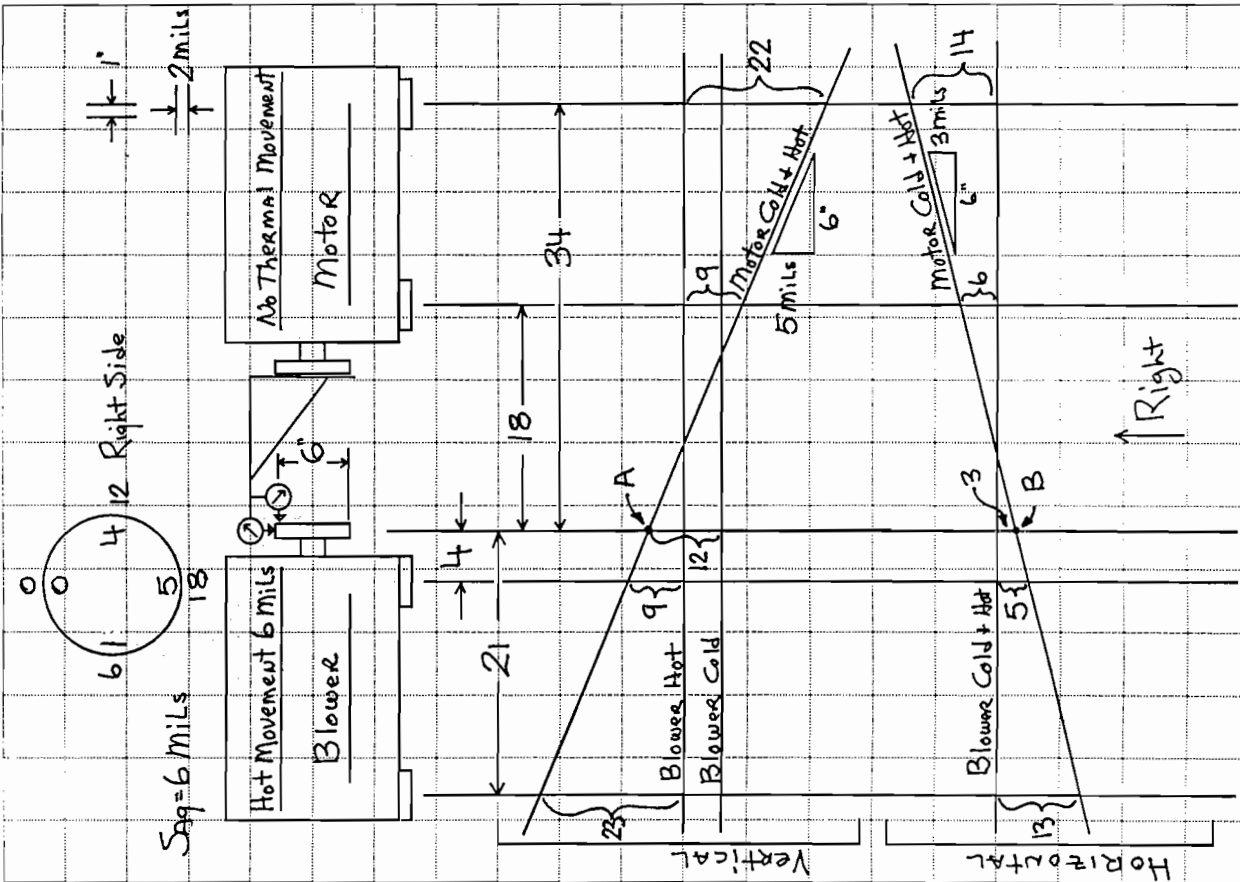
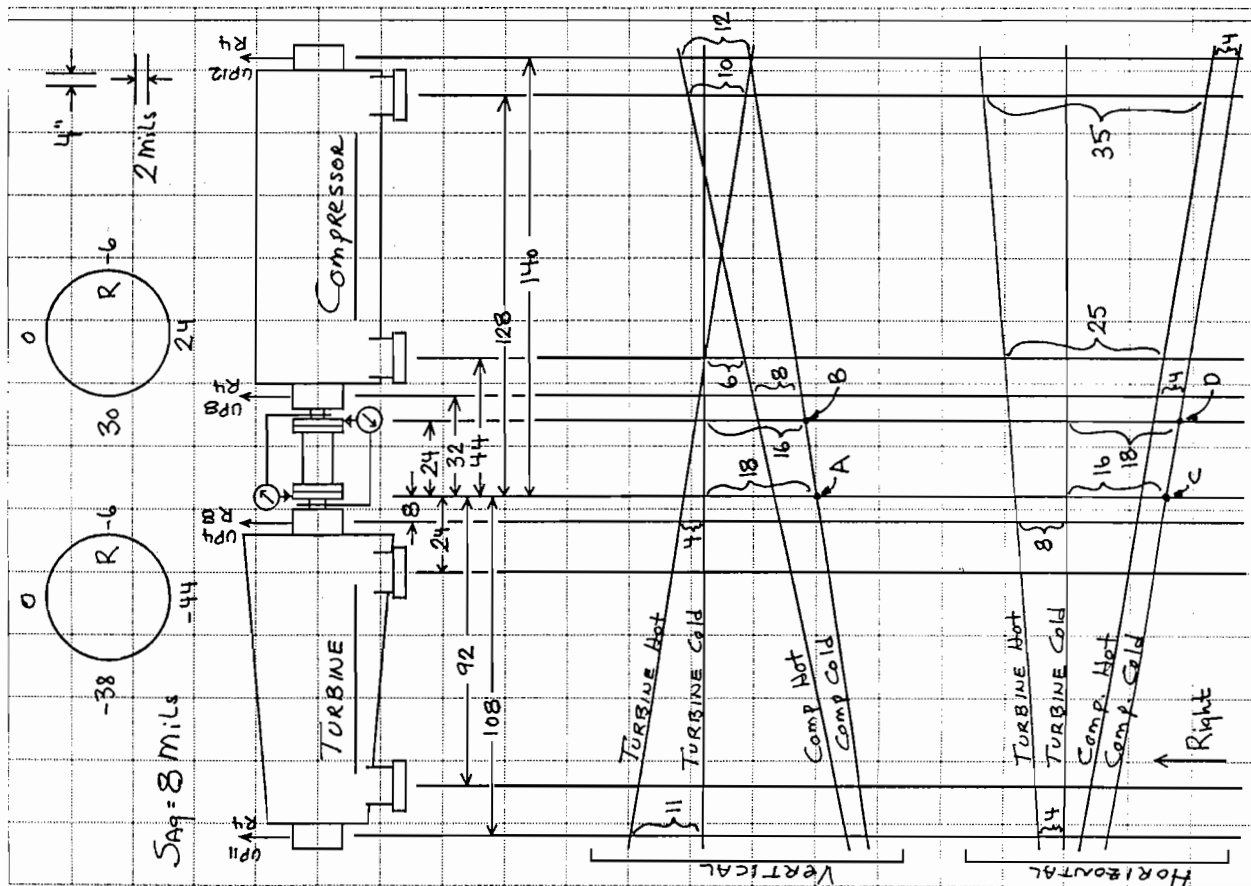

Figure 20. Face and Rim Method Plot for Routine Equipment.

Figure 21. Reverse Indicator Method Plot for Vital Equipment.



Plotting Instructions
Reverse Indicator Alignment - Vital Equipment
(Figure 21)

- Prepare a scaled plot of the equipment to be aligned. To enhance accuracy, make the plot as large as possible (11 in x 17 in minimum is preferred). Choose a scale that will maximize the size of the plot, and use care in laying out dimensions. Usefulness of results depend upon the accuracy of the plot. For this plot, the scale is 4 inches per division horizontally; 2 mils per division vertically. For critical equipment where thermal growth is non-uniform, dimensions to planes of thermal growth measurements are required as well as measurements to machine supports.
- Correct the dial indicator readings for sag and for ease of plotting.

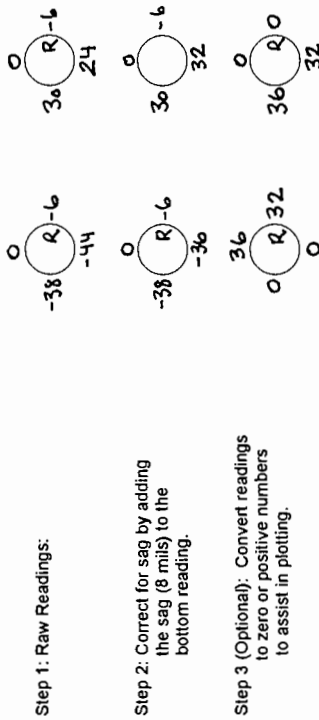

- Draw a "Turbine Cold" line on the graph to represent the vertical position of the machine in the cold condition. Using the scale of 2 mils per vertical division, lay out the "Turbine Hot" line which is 11 mils above the cold line at the outboard end and 4 mils above the cold line at the inboard end. Note that the thermal growth readings are *not* at machine supports.
- Similarly, draw a "Turbine Cold" line to represent the horizontal position of the machine in the cold condition. Next, draw the "Turbine Hot" line which is 4 mils to the right of the cold line at the outboard end, and 8 mils to the right at the coupling end. Note again that the thermal movement readings are *not* at the machine supports. Identify the right-hand side of the machinery train.
- Referring to the corrected dial indicator readings above, locate points "A" and "B" through which the compressor shaft must pass. Point "A" is located 18 mils below the centerline of the turbine in the cold condition. Point "B" is 16 mils below the turbine cold position. The "Compressor Cold" line passes through points "A" and "B". Next, draw the "Compressor Hot" line which is 8 mils above the cold line at the coupling end, and 12 mils above the cold line at the outboard end.
- Similarly, locate points "C" and "D" in the horizontal plane. Point "C" is 16 mils to the left of the turbine in the cold condition, and point "D" is 18 mils to the left. Draw the "Compressor Cold" line through points "C" and "D". Now plot the "Compressor Hot" line which is 4 mils to the right of the cold position at both the coupling and outboard ends.
- Using the chosen scale, determine vertical and horizontal movements required to improve alignment. For this example, required compressor movements are 6 mils upward and 25 mils to the right at the coupling-end support; 10 mils downward and 35 mils to the right at the outboard support. If desired, similar data can be obtained from the plot for moving the turbine instead of the compressor.

Plotting Instructions
Face and Rim Alignment - Vital Equipment
 (Figure 22)

- Prepare a scaled plot of the equipment to be aligned. To enhance accuracy, make the plot as large as possible (11 in x 17 in minimum is preferred). Choose a scale that will maximize the size of the plot, and use care in laying out dimensions. Usefulness of results depend upon the accuracy of the plot. For this plot, the scale is 4 inches per division horizontally, 2 mils per division vertically. For critical equipment where thermal growth is non-uniform, dimensions to planes of thermal growth measurements are required as well as measurements to machine supports.
- Correct the dial indicator readings for sag and for ease of plotting.

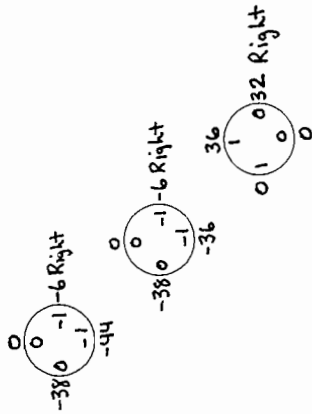

Step 1: Raw Readings:

Step 2: Correct for sag by adding the sag (8 mils) to the bottom reading.

Step 3 (Optional): Convert readings to zero or positive numbers to assist in plotting.

- Draw a "Turbine Cold" line on the graph to represent the vertical position of the machine in the cold condition. Using the scale of 2 mils per vertical division, lay out the "Turbine Hot" line which is 11 mils above the cold line at the outboard end and 4 mils above the cold line at the inboard end. Note that the thermal growth readings are *not* at machine supports.
- Similarly, draw a "Turbine Cold" line to represent the horizontal position of the machine in the cold condition. Next, draw the "Turbine Hot" line which is 4 mils to the right of the cold line at the outboard end, and 8 mils to the right at the coupling end. Note again that the thermal movement readings are *not* at the machine supports. Identify the right-hand side of the machinery train.
- Referring to the corrected dial indicator readings above, locate point "A" through which the compressor shaft must pass. Point "A" is located 18 mils below the centerline of the turbine in the cold condition. From examination of the face readings, it is ascertained that the compressor slopes upward from point "A" at an angle of 1 mil per 12". Draw the "Compressor Cold" line through point "A" at an angle of 1 mil per 12". Next, draw the "Compressor Hot" line which is 8 mils above the cold line at the coupling end, and 12 mils above the cold line at the outboard end.
- Similarly, locate point "B" in the horizontal plane. Point "B" is 16 mils to the left of the turbine in the cold condition. Examination of face readings reveals that the compressor shaft slopes to the left from point "B" at an angle of 1 mil per 12 inches. Draw the "Compressor Cold" line through points "B" at an angle of 1 mil per 12 inches. Now plot the "Compressor Hot" line which is 4 mils to the right of the cold position at both the coupling and outboard ends.
- Using the chosen scale, determine vertical and horizontal movements required to improve alignment. For this example, required compressor movements are 6 mils upward and 25 mils to the right at the coupling-end support; 10 mils downward and 35 mils to the right at the outboard support. If desired, similar data can be obtained from the plot for moving the turbine instead of the compressor.

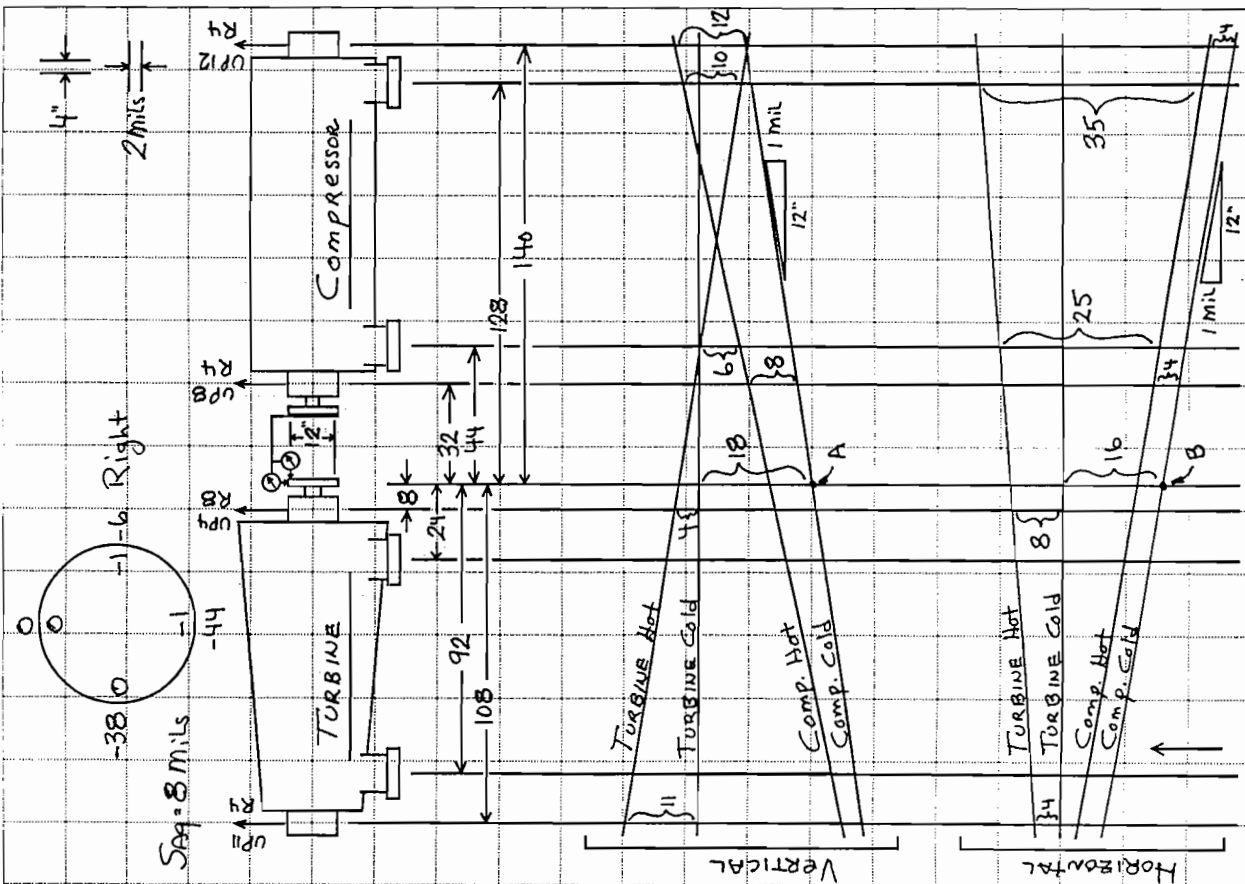

Figure 22. Face and Rim Method Plot for Vital Equipment.

Most authorities suggest that a hot alignment check should be done on virtually all vital equipment, on equipment of high horsepower and/or high speed, and on equipment operating at other than ambient temperatures. These are probably valid suggestions. In practice, however, alignment checks are actually done on only a small percentage of machines.

A recent telephone survey of engineers responsible for rotating equipment with a number of large companies revealed the following: Predominately, hot checks are routinely conducted on the largest and most vital equipment such as centrifugal compressor trains, but are conducted on other equipment only if a problem is evident. A few users report that hot checks are conducted only if vibration analyses indicate a problem, regardless of equipment size and/or criticality. Practices seem to have changed very little over the past two decades.

In view of increasing pressures for higher reliability, longer run times, and reduced maintenance costs, it is surprising that routine hot checks are not more widely done. It would appear to be a fruitful area to pursue. The following are common procedures.

• *Manufacturers' Recommendations.* For major equipment, it is common for the manufacturer to provide data concerning expected thermal growth. These data may be calculated, they may reflect experience from similar or identical machines, or some combination of the two. These data are normally used for initial machine installation.

Experiences with manufacturers' data vary. If similar machines have been built and tested, if the machines are operated near design conditions, and if they are not unduly influenced by outside factors such as pipe strain, then the vendor data may be excellent. For some machines, however, vendor data do not approximate field measurements.

For machines in vital applications, it is generally agreed that vendor data should be verified by a hot check.

Precaution: Be wary of thermal growth data that is vague. If, for example, the data simply says that the discharge end of a compressor is expected to grow vertically 0.012 in, and there is no expected growth on the suction end, be very careful. To be useful, the data must say precisely where the growth is expected, i.e., at the coupling, at the machine supports, or at the equipment flange. Do not use vague data.

• *Calculations.* Thermal growth calculations are sometimes done on the basis of machine geometry and measured or calculated metal temperatures. While such calculations are better than nothing, they are generally not very reliable. Additionally, they do not account for external loads such as piping, which may be substantial. If calculations are used for initial installation, they should be verified by a hot check.

• *The Traditional Hot Check.* The so-called traditional hot check involves running the equipment until thermal equilibrium is achieved, then shutting the machine down and quickly taking alignment data with the same tools used to align the equipment initially. It may or may not involve removing the coupling.

Except in rare cases, the results of this type of hot check have proved to be very poor. First, the procedure requires a machine shutdown that is often costly and unpopular with operating personnel. Secondly, the equipment cools down very quickly after shutdown, as does any connecting piping. Hydraulic effects, if any, are lost immediately. Moreover, it is virtually impossible to take readings quickly enough to assure that they are meaningful, and data simply cannot be verified because the machines are moving during the exercise. An additional concern is personnel safety. If the machines are very hot, it is questionable that people should be asked to work on them.

• *Online Methods.* Because of the shortcomings of the methods mentioned above, a number of online hot check methods have been developed. Figures 23, 24, 25, 26, 27, and 28 are conceptual depictions of these various methods, all of which are field-proven. While details of the various methods are beyond the scope of this presentation, appropriate material is noted in the reference section. Additionally, many of the manufacturers and vendors of this equipment, as well as those providing alignment services, are among the exhibitors at the Symposium.

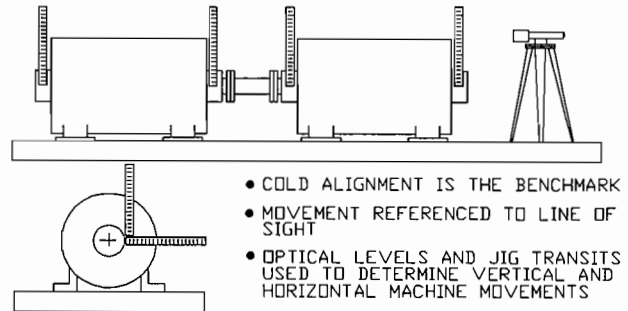

Figure 23. Hot Check by Optical Means.

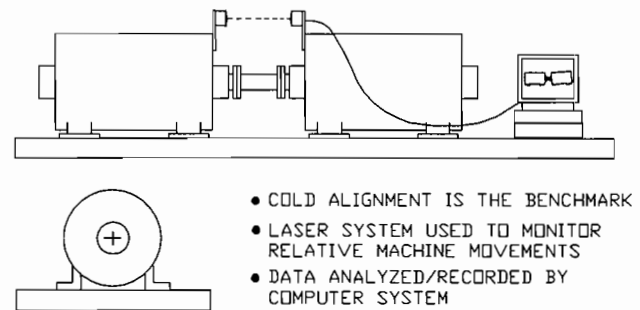

Figure 24. Hot Check by Laser Systems.

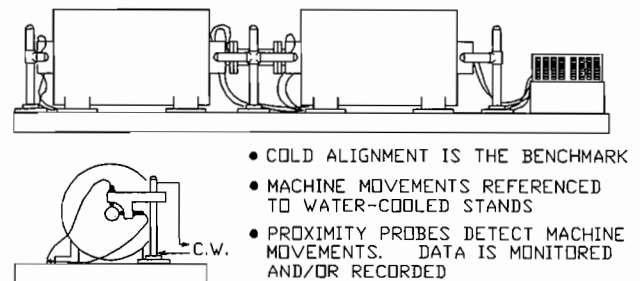

Figure 25. Hot Check by Water Cooled Stands and Proximity Probes.

While all of these methods can provide reliable online alignment data, they vary greatly in cost, complexity, and ease of use. Moreover, none of the methods are applicable to every situation. No attempt is made to provide comparative data. The user is urged to review the merits of each system, and to choose the system that best fits the need.

Precaution: With the exception of instrumented couplings, all of the methods listed below use cold coupling alignment readings as baseline from which to calculate (or plot) hot coupling alignment. It is vital, therefore, whatever method is used, that

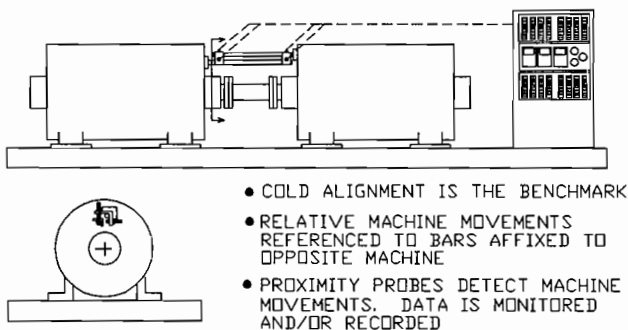

Figure 26. Hot Check by Dynalign (Dodd) Bars.

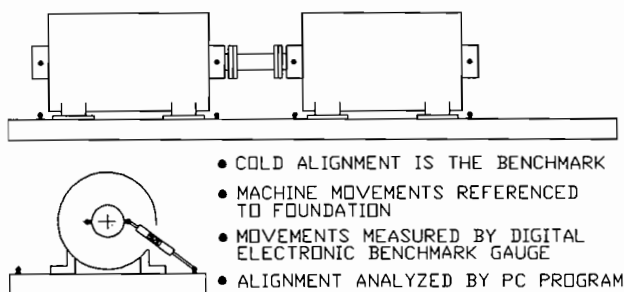

Figure 27. Hot Check by Benchmark Gauges.

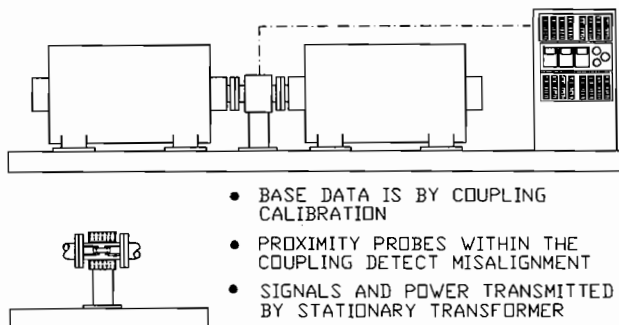

Figure 28. Hot Check by Instrumented Couplings.

the "cold" baseline data be taken at the same time the cold coupling alignment data is taken. Reliable results simply cannot be obtained by taking coupling data in the cool of the morning, for example, and hot alignment baseline data in the blazing afternoon sunshine. Take the data simultaneously.

• *Optical Methods.* Optical methods (Figure 23) employ very precise surveying techniques to determine machine movements, from which shaft alignment information can be ascertained. To use this method, coupling alignment is done in a conventional manner after which vertical and horizontal baseline data are obtained with precision levels and transits. When the equipment is put on line and brought to equilibrium, this same optical instrumentation is used to determine the movement of each of the machines with respect to the baseline data. From these data, running alignment can be plotted or calculated.

While some companies employ inhouse specialists to conduct hot alignment checks by optical methods, it is more common to use one of the several commercial firms who offer these services.

• *Lasers.* Several variations of laser monitoring (Figure 24) are available. Typically, machines are aligned in a conventional

manner, and a laser/reflector system is used to monitor the movement of one machine casing with respect to the adjacent casing. From these data, coupling alignment can be determined by plotting or calculations.

In some systems, the laser equipment is mounted permanently upon the equipment. In other systems, brackets are used to permit the lasers to be installed and/or removed during operation.

• *Proximity probes with water-cooled stands.* With this method (Figure 25), water-cooled stands are affixed to the foundation near couplings and outboard bearing housings. These stands are used to support electronic proximity probes that monitor the movement of the coupling, shafts, and/or machine casings relative to the foundation.

With this method, coupling alignment is done in a conventional manner at which time baseline proximity probe readings are taken. Equipment movements are monitored via these probes as the equipment is brought online and comes to equilibrium, and they may be recorded. Movement of the equipment relative to the proximity probes provides data from which to determine running alignment of the equipment.

• *Dynalign (Dodd) Bars.* This is a method (Figure 26) of continuous, online monitoring, using proximity probes that are fastened to permanently mounted brackets on the coupled machines. The brackets are arranged in a fashion similar to that of indicator brackets used in the *Reverse Alignment Method*. Vertical and horizontal data from four probes supply information concerning the relative movement of the machine casings.

With this method, cold alignment is done in the normal manner and baseline data is secured from the probes. Output from the probes can then be monitored and/or recorded. Data is sufficient to plot, calculate, or display running alignment of the equipment.

• *Benchmark Gauges.* This system (Figure 27) monitors the movement of bearing housings or machine casings with respect to the equipment foundation. To use this system, permanent benchmarks are mounted on the equipment and the foundation. Upon alignment of the equipment in a conventional manner, benchmark gauges are used to determine baseline measurements between the foundation mounted benchmarks and those mounted on the equipment. When the machines are brought online, benchmark gauge readings are again taken to determine the relative movement of the equipment.

Running alignment of the coupling is normally calculated by a PC program, but can be determined by graphical methods, also.

• *Instrumented Couplings.* With this system (Figure 28), electronic probes are built into the coupling spacer. Power is supplied to the probes via a stationary transformer, and signals from the probes are retrieved in a similar manner. This arrangement provides online, continuous monitoring of coupling alignment and axial movement of the coupled shafts.

CONCLUSION

Satisfactory and long lasting alignment is achieved by paying attention to details throughout the design, fabrication, and installation of the equipment. Toward this end, the following are minimal requirements:

- Rotating equipment that is properly designed and well made.
- A well-designed and properly executed system into which the equipment is integrated.
- Knowledgeable, careful, and experienced craftsmen.

- Proper training of both craftsmen and supervisory personnel.
- Appropriate tools.
- Standards and/or specifications detailing alignment requirements.
- A system to assure that job specifications are followed.

APPENDIX A

The following is the listing of a computer program for calculating shaft-to-spacer alignment using *Face and Rim* or *Reverse Indicator Methods*. The program was written using Microsoft QuickBASIC 4.0.

Before using this program, the user is cautioned to determine the suitability for his or her specific application.

```

MENU:
CLS : COLOR 7, 9: CLS
LOCATE 4, 20: PRINT "THIS PROGRAM CALCULATES MISALIGNMENT OF "
LOCATE 5, 20: PRINT "THE COUPLING SPACER WITH RESPECT TO THE"
LOCATE 6, 24: PRINT "SHAFTS OF THE COUPLED MACHINES"
LOCATE 9, 33: PRINT "OPTIONS ARE:"
LOCATE 11, 22: PRINT "(1) FACE & RIM ALIGNMENT"
LOCATE 13, 22: PRINT "(2) REVERSE INDICATOR ALIGNMENT"
LOCATE 15, 22: PRINT "(3) PRINTOUT OF PROGRAM ASSUMPTIONS"
LOCATE 17, 22: PRINT "(4) EXIT THE PROGRAM"
LOCATE 20, 22: COLOR 1, 7: PRINT " PLEASE ENTER OPTION 1,2,3 OR 4 "

CHECK1: KS = "": KS = INKEY$
IF KS = "1" THEN TYPES = "FR": GOTO FACERIMDATA
IF KS = "2" THEN TYPES = "RI": GOTO REVERSEINDDATA
IF KS = "3" THEN GOTO INSTRUCTIONS
IF KS = "4" THEN GOTO QUIT
GOTO CHECK1

FACERIMDATA:
COLOR 7, 9: CLS : PRINT
PRINT "          GENERAL DATA FOR THE FACE & RIM METHOD:" PRINT

PRINT " THE BRACKET IS FASTENED TO THE          (PUMP, MOTOR, ETC) "
LOCATE 4, 37: COLOR 1, 7: PRINT "
LOCATE 4, 37: INPUT " , AS
LOCATE 4, 37: COLOR 7, 9: PRINT "
LOCATE 4, 37: PRINT AS: PRINT : LOCATE 4, 51: PRINT " : PRINT

PRINT " THE DIAL INDICATORS READ ON THE          (PUMP, MOTOR, ETC) "
LOCATE 6, 38: COLOR 1, 7: PRINT "
LOCATE 6, 38: INPUT " , BS
LOCATE 6, 38: COLOR 7, 9: PRINT "
LOCATE 6, 38: PRINT BS: PRINT : LOCATE 6, 52: PRINT "

PRINT : PRINT : PRINT " THERMAL GROWTH OF THE " , AS , " IS " ;
LOCATE 9, 45: COLOR 1, 7: PRINT " " ;
COLOR 7, 9: PRINT " MILS
LOCATE 9, 45: COLOR 1, 7: INPUT " , AGROWTH: COLOR 7, 9
TEMP = AGROWTH: GOSUB MILCHECK
IF FLAG1 = 1 THEN AGROWTH = AGROWTH * 1000: FLAG1 = 0
LOCATE 9, 8: PRINT "THERMAL GROWTH OF THE " , AS , " IS " , AGROWTH , " MILS "

PRINT : PRINT " THERMAL GROWTH OF THE " , BS , " IS " ;
LOCATE 11, 45: COLOR 1, 7: PRINT " " ;
COLOR 7, 9: PRINT " MILS
LOCATE 11, 45: COLOR 1, 7: INPUT " , BGROWTH: COLOR 7, 9
TEMP = BGROWTH: GOSUB MILCHECK
IF FLAG1 = 1 THEN BGROWTH = BGROWTH * 1000: FLAG1 = 0
LOCATE 11, 8: PRINT "THERMAL GROWTH OF THE " , BS , " IS " , BGROWTH , " MILS "

PRINT : PRINT : PRINT " DISTANCE BETWEEN THE FLEXIBLE ELEMENTS
PRINT " OF THE COUPLING IS " ;
COLOR 1, 7: PRINT " " ;
COLOR 7, 9: PRINT " (INCHES)"
LOCATE 15, 25: COLOR 1, 7: INPUT " , SP: COLOR 7, 9
IF SP < 2 THEN GOSUB SPACERTEST
LOCATE 15, 8: PRINT "OF THE COUPLING IS " , SP , " INCHES "

PRINT : PRINT " FACE DIAMETER AT WHICH INDICATOR
PRINT " READINGS ARE TAKEN " ;
COLOR 1, 7: PRINT " " ;
COLOR 7, 9: PRINT " (INCHES)"
LOCATE 18, 25: COLOR 1, 7: INPUT " , DIA: COLOR 7, 9
LOCATE 18, 8: PRINT "READINGS ARE TAKEN " , DIA , " INCHES "

PRINT : PRINT " THE SAG OF THE INDICATOR BRACKET IS " ;
COLOR 1, 7: PRINT " " ;
COLOR 7, 9: PRINT " (MILS)"
LOCATE 20, 42: COLOR 1, 7: INPUT " , SAG: SAG = ABS(SAG): COLOR 7, 9
TEMP = SAG: GOSUB MILCHECK
IF FLAG1 = 1 THEN SAG = SAG * 1000: FLAG1 = 0
LOCATE 20, 6: PRINT "THE SAG OF THE INDICATOR BRACKET IS " , SAG , " MILS
PRINT : PRINT " DO YOU WISH TO CHANGE ANY OF THIS DATA " ;
COLOR 1, 7: PRINT "(Y OR N)?: " COLOR 7, 9

CHECK2:
KS = "": KS = INKEY$

```

```

IF KS = "Y" THEN GOTO FACERIMDATA
IF KS = "Y" THEN GOTO FACERIMDATA
IF KS = "N" THEN GOTO RIMREADINGS
IF KS = "N" THEN GOTO RIMREADINGS
GOTO CHECK2

```

```

RIMREADINGS:
FLAG2 = 1: CLS : PRINT : PRINT : PRINT
LOCATE 4, 21: PRINT "INPUT DIAL INDICATOR RIM READINGS (MILS):" PRINT
LOCATE 8, 32: INPUT " TOP " , ATOP: TEMP = ATOP: GOSUB MILCHECK
LOCATE 7, 32: INPUT " RIGHT " , ARIGHT: TEMP = ARIGHT: GOSUB MILCHECK
LOCATE 8, 32: INPUT " BOTTOM " , ABOTTOM: TEMP = ABOTTOM: GOSUB MILCHECK
LOCATE 9, 32: INPUT " LEFT " , ALEFT: TEMP = ALEFT: GOSUB MILCHECK
TOP1 = ATOP: RGH1 = ARIGHT: BOTTOM1 = ABOTTOM: LEFT1 = ALEFT: PRINT : FLAG2 = 0

```

```

DIALCHECK = (ATOP + ABOTTOM) - (ARIGHT + ALEFT)
IF ABS(DIALCHECK) < 1.5 THEN GOTO CHANGE1:
LOCATE 11, 15: PRINT "CAUTION: RIM READINGS DO NOT ADD UP."
LOCATE 12, 15: PRINT " TOP PLUS BOTTOM SHOULD EQUAL RIGHT PLUS LEFT."

```

```

CHANGE1:
LOCATE 15, 15: PRINT " DO YOU WISH TO CHANGE THE READINGS " ;
COLOR 1, 7: PRINT "(Y OR N)?: " COLOR 7, 9

```

```

CHECK3:
KS = "": KS = INKEY$
IF KS = "Y" THEN CLS : GOTO RIMREADINGS
IF KS = "Y" THEN CLS : GOTO RIMREADINGS
IF KS = "N" THEN GOTO FACEREADINGS
IF KS = "N" THEN GOTO FACEREADINGS
GOTO CHECK3

```

```

FACEREADINGS:
FLAG3 = 1: CLS : LOCATE 4, 21: PRINT "INPUT DIAL INDICATOR FACE READINGS (MILS)

```

```

LOCATE 6, 32: INPUT " TOP " , FACETOP: TEMP = FACETOP: GOSUB MILCHECK:
LOCATE 7, 32: INPUT " RIGHT " , FACERIGHT: TEMP = FACERIGHT: GOSUB MILCHECK
LOCATE 8, 32: INPUT " BOTTOM " , FACEBOTTOM: TEMP = FACEBOTTOM: GOSUB
MILCHECK
LOCATE 9, 32: INPUT " LEFT " , FACELEFT: TEMP = FACELEFT: GOSUB MILCHECK
TOP2 = FACETOP: RIGHT2 = FACERIGHT: BOTTOM2 = FACEBOTTOM: LEFT2 = FACELEFT:
FLAG3 = 0

```

```

PRINT : DIALCHECK = (FACETOP + FACEBOTTOM) - (FACERIGHT + FACELEFT)
IF ABS(DIALCHECK) < 1.5 THEN GOTO CHANGE2:
LOCATE 11, 15: PRINT "CAUTION: FACE READINGS DO NOT ADD UP."
LOCATE 12, 15: PRINT " TOP PLUS BOTTOM SHOULD EQUAL RIGHT PLUS LEFT."
PRINT

```

```

CHANGE2:
LOCATE 15, 15: PRINT " DO YOU WISH TO CHANGE THE READINGS " ;
COLOR 1, 7: PRINT "(Y OR N)?: " COLOR 7, 9

```

```

CHECK4:
KS = "": KS = INKEY$
IF KS = "Y" THEN CLS : GOTO FACEREADINGS
IF KS = "Y" THEN CLS : GOTO FACEREADINGS
IF KS = "N" THEN GOTO CALCULATIONS
IF KS = "N" THEN GOTO CALCULATIONS
GOTO CHECK4

```

```

REVERSEINDDATA:
COLOR 7, 9: CLS : PRINT
PRINT "          GENERAL DATA FOR THE REVERSE INDICATOR METHOD "

```

```

PRINT : PRINT " ONE COUPLED MACHINES IS THE          (PUMP, MOTOR, ETC) "
LOCATE 4, 34: COLOR 1, 7: PRINT "
LOCATE 4, 34: INPUT " , AS
LOCATE 4, 34: COLOR 7, 9: PRINT "
LOCATE 4, 34: PRINT AS: PRINT : LOCATE 4, 51: PRINT "

```

```

PRINT
PRINT " THE OTHER COUPLED MACHINE IS THE          (PUMP, MOTOR, ETC) "
LOCATE 6, 38: COLOR 1, 7: PRINT "
LOCATE 6, 38: INPUT " , BS
LOCATE 6, 38: COLOR 7, 9: PRINT "
LOCATE 6, 38: PRINT BS: PRINT : LOCATE 6, 52: PRINT "

```

```

PRINT : PRINT " THERMAL GROWTH OF THE " , AS , " IS " ;
LOCATE 9, 45: COLOR 1, 7: PRINT " " ;
COLOR 7, 9: PRINT " MILS
LOCATE 9, 45: COLOR 1, 7: INPUT " , AGROWTH: COLOR 7, 9
TEMP = AGROWTH: GOSUB MILCHECK
IF FLAG1 = 1 THEN AGROWTH = AGROWTH * 1000: FLAG1 = 0
LOCATE 9, 8: PRINT "THERMAL GROWTH OF THE " , AS , " IS " , AGROWTH , " MILS "

```

```

PRINT : PRINT " THERMAL GROWTH OF THE " , BS , " IS " ;
LOCATE 11, 45: COLOR 1, 7: PRINT " " ;
COLOR 7, 9: PRINT " MILS
LOCATE 11, 45: COLOR 1, 7: INPUT " , BGROWTH: COLOR 7, 9
TEMP = BGROWTH: GOSUB MILCHECK
IF FLAG1 = 1 THEN BGROWTH = BGROWTH * 1000: FLAG1 = 0
LOCATE 11, 8: PRINT "THERMAL GROWTH OF THE " , BS , " IS " , BGROWTH , " MILS "

```

```

LOCATE 13, 8: PRINT "THE DISTANCE BETWEEN THE PLANES WHERE THE
LOCATE 14, 8: PRINT "DIAL INDICATOR READINGS ARE TAKEN IS          (INCHES) "
LOCATE 14, 43: COLOR 1, 7: PRINT " " ; COLOR 7, 9
LOCATE 14, 43: COLOR 1, 7: INPUT " , SEPARATION: COLOR 7, 9
LOCATE 14, 8: PRINT "DIAL INDICATOR READINGS ARE TAKEN IS " , SEPARATION , " INCHES "

```

```

LOCATE 16, 8: PRINT "THE DISTANCE BETWEEN THE FLEXIBLE ELEMENTS "

```

```

LOCATE 17, 8: PRINT "OF THE COUPLING IS ";
COLOR 1, 7: PRINT " ";
COLOR 7, 9: PRINT " (INCHES)"
LOCATE 17, 25: COLOR 1, 7: INPUT " "; SP: COLOR 7, 9
IF SP < 2 THEN GOSUB SPACERTST
LOCATE 17, 8: PRINT "OF THE COUPLING IS "; SP; " INCHES "

LOCATE 19, 8: PRINT "THE SAG OF THE INDICATOR BRACKET IS ";
COLOR 1, 7: PRINT " ";
COLOR 7, 9: PRINT " (MILS)"
LOCATE 19, 42: COLOR 1, 7: INPUT " "; SAG: SAG = ABS(SAG): COLOR 7, 9
TEMP = SAG: GOSUB MILCHECK
IF FLAG1 = 1 THEN SAG = SAG * 1000: FLAG1 = 0
LOCATE 19, 8: PRINT "THE SAG OF THE INDICATOR BRACKET IS "; SAG; " MILS "

PRINT : PRINT : PRINT " DO YOU WISH TO CHANGE ANY OF THIS DATA ";
COLOR 1, 7: PRINT "(Y OR N)?: "; COLOR 7, 9

CHECKS:
K$ = " ": K$ = INKEY$
IF K$ = "Y" THEN GOTO REVERSEINDDATA
IF K$ = "Y" THEN GOTO REVERSEINDDATA
IF K$ = "N" THEN GOTO REVERSEA
IF K$ = "n" THEN GOTO REVERSEA

GOTO CHECKS

REVERSEA:
FLAG4 = 1: CLS : LOCATE 4, 26: PRINT "INPUT READINGS FROM THE DIAL "
LOCATE 5, 26: PRINT "INDICATOR NEAREST THE "; AS
LOCATE 9, 31: INPUT " TOP "; ATOP: TEMP = ATOP: GOSUB MILCHECK
LOCATE 10, 31: INPUT " RIGHT "; ARIGHT: TEMP = ARIGHT: GOSUB MILCHECK
LOCATE 11, 31: INPUT " BOTTOM "; ABOTTOM: TEMP = ABOTTOM: GOSUB MILCHECK
LOCATE 12, 31: INPUT " LEFT "; ALEFT: TEMP = ALEFT: GOSUB MILCHECK
TOP1 = ATOP: RIGHT1 = ARIGHT: BOTTOM1 = ABOTTOM: LEFT1 = ALEFT: FLAG4 = 0
PRINT : DIALCHECK = (ATOP + ABOTTOM) - (ARIGHT + ALEFT)
IF ABS(DIALCHECK) < 1.5 THEN GOTO CHANGE8:
LOCATE 14, 15: PRINT "CAUTION: READINGS DO NOT ADD UP."
LOCATE 15, 15: PRINT " TOP PLUS BOTTOM SHOULD EQUAL RIGHT PLUS LEFT."

CHANGE8:
LOCATE 17, 15: PRINT " DO YOU WISH TO CHANGE THE READINGS ";
COLOR 1, 7: PRINT "(Y OR N)?: "; COLOR 7, 9

CHECK8:
K$ = " ": K$ = INKEY$
IF K$ = "Y" THEN GOTO REVERSEA
IF K$ = "Y" THEN GOTO REVERSEA
IF K$ = "N" THEN GOTO REVERSEB
IF K$ = "n" THEN GOTO REVERSEB
GOTO CHECK8

REVERSEB:
FLAG5 = 1: CLS : LOCATE 4, 24: PRINT "INPUT READINGS FROM THE DIAL "
LOCATE 5, 24: PRINT "INDICATORS NEAREST THE "; B$
LOCATE 8, 30: INPUT " TOP "; BTOP: TEMP = BTOP: GOSUB MILCHECK
LOCATE 9, 30: INPUT " RIGHT "; BRIGHT: TEMP = BRIGHT: GOSUB MILCHECK
LOCATE 10, 30: INPUT " BOTTOM "; BBOTTOM: TEMP = BBOTTOM: GOSUB MILCHECK
LOCATE 11, 30: INPUT " LEFT "; BLEFT: TEMP = BLEFT: GOSUB MILCHECK
TOP2 = BTOP: RIGHT2 = BRIGHT: BOTTOM2 = BBOTTOM: LEFT2 = BLEFT: FLAG5 = 0
DIALCHECK = (BTOP + BBOTTOM) - (BRIGHT + BLEFT)
IF ABS(DIALCHECK) < 1.5 THEN GOTO CHANGE4:
LOCATE 14, 15: PRINT "CAUTION: READINGS DO NOT ADD UP."
LOCATE 15, 15: PRINT " TOP PLUS BOTTOM SHOULD EQUAL RIGHT PLUS LEFT."

CHANGE4:
LOCATE 17, 15: PRINT " DO YOU WISH TO CHANGE THE READINGS ";
COLOR 1, 7: PRINT "(Y OR N)?: "; COLOR 7, 9

CHECK7:
K$ = " ": K$ = INKEY$
IF K$ = "Y" THEN GOTO REVERSEB
IF K$ = "Y" THEN GOTO REVERSEB
IF K$ = "N" THEN GOTO CALCULATIONS
IF K$ = "n" THEN GOTO CALCULATIONS
GOTO CHECK7

CALCULATIONS:
ABOTTOM = ABOTTOM + SAG
BBOTTOM = BBOTTOM + SAG
IF TYPE$ = "R" THEN GOTO EQUIVALENTS

BTOP = 0: BRIGHT = 0
BBOTTOM = 2 * (((ATOP - ABOTTOM) / 2) + ((FACEBOTTOM - FACETOP) * (SP / DIA)))
BLEFT = 2 * (((ARIGHT - ALEFT) / 2) + ((FACELEFT - FACERIGHT) * (SP / DIA)))

GOTO COLDOFFSET:

REM EQUIVALENTS CALCULATES EQUIVALENT DIAL READINGS FOR THE REVERSE
REM INDICATOR METHOD WHERE THE SPACER MAY BE A DIFFERENT LENGTH FROM
REM THE INDICATOR SEPARATION

EQUIVALENTS:
AT = ATOP: AR = ARIGHT: AB = ABOTTOM: AL = ALEFT
BT = BTOP: BR = BRIGHT: BB = BBOTTOM: BL = BLEFT

A = (AT - AB) / 2: B = (BB - BT) / 2: S = SP: D = SEPARATION
C = (D - S) / 2: F = D - C: G = A - B: H = G * (F / D): J = B + H
K = G * (C / D): L = B + K
ABOTTOM = 0: ATOP = 2 * J: BTOP = 0: BBOTTOM = 2 * L

A = (AR - AL) / 2: B = (BL - BR) / 2: G = A - B: H = G * (F / D): J = B + H
K = G * (C / D): L = B + K

```

```

ALEFT = 0: ARIGHT = 2 * J: BRIGHT = 0: BLEFT = 2 * L

```

COLD OFFSET:

```

REM: ACOLD AND BCOLD ARE THE TOTAL ANGULAR OFFSETS OF THE COUPLINGS AT
REM: MACHINES A AND B RESPECTIVELY, MILS PER INCH OF COUPLING LENGTH
BCOLD = (((ATOP - ABOTTOM) / 2) ^ 2 + (((ARIGHT - ALEFT) / 2) ^ 2) ^ .5) / SP
ACOLD = (((BTOP - BBOTTOM) / 2) ^ 2 + (((BRIGHT - BLEFT) / 2) ^ 2) ^ .5) / SP

```

```

REM: BANGCOLD IS THE COLD ANGULAR OFFSET AT MACHINE B, DEGREES
REM: AANGCOLD IS THE COLD ANGULAR OFFSET AT MACHINE A, DEGREES
BANGCOLD = BCOLD * .057296
AANGCOLD = ACOLD * .057296

```

```

REM: ADDS THERMAL GROWTH TO CALCULATIONS FOR HOT ALIGNMENT CALCULATIONS

```

```

IF TYPE$ = "R" THEN ABOTTOM = ABOTTOM - 2 * (AGROWTH - BGROWTH)
IF TYPE$ = "R" THEN BBOTTOM = BBOTTOM + 2 * (AGROWTH - BGROWTH)
IF TYPE$ = "FR" THEN ABOTTOM = ABOTTOM + 2 * (AGROWTH - BGROWTH)
IF TYPE$ = "FR" THEN BBOTTOM = BBOTTOM - 2 * (AGROWTH - BGROWTH)

```

HOTCALC:

```

REM: BHOT AND AHOT ARE THE TOTAL ANGULAR OFFSETS OF THE COUPLINGS AT
REM: MACHINES B AND A RESPECTIVELY, MILS PER INCH OF COUPLING LENGTH
BHOT = (((ATOP - ABOTTOM) / 2) ^ 2 + (((ARIGHT - ALEFT) / 2) ^ 2) ^ .5) / SP
AHOT = (((BTOP - BBOTTOM) / 2) ^ 2 + (((BRIGHT - BLEFT) / 2) ^ 2) ^ .5) / SP

```

```

REM: BANGHOT IS THE HOT ANGULAR OFFSET AT MACHINE B, DEGREES
REM: AANGHOT IS THE HOT ANGULAR OFFSET AT MACHINE A, DEGREES
BANGHOT = BHOT * .057296
AANGHOT = AHOT * .057296

```

ANSWERS:

```

REM SELECT THE MAJOR MISALIGNMENT IN THE COLD CONDITION
IF ACOLD >= BCOLD THEN MAXCOLD = ACOLD: COLDS = AS: COLDANG = MAXCOLD *
.057296
IF BCOLD >= ACOLD THEN MAXCOLD = BCOLD: COLDS = BS: COLDANG = MAXCOLD *
.057296

```

```

REM SELECT THE MAJOR MISALIGNMENT IN THE AHOT CONDITION

```

```

IF AHOT >= BHOT THEN MAXHOT = AHOT: HOT$ = AS: HOTANG = MAXHOT * .057296
IF BHOT >= AHOT THEN MAXHOT = BHOT: HOT$ = BS: HOTANG = MAXHOT * .057296

```

```

CLS : LOCATE 4, 17: PRINT "COLD: THE MAXIMUM COLD MISALIGNMENT IS AT THE"
LOCATE 5, 18: PRINT " FLEXIBLE ELEMENT NEAR THE "; COLDS
LOCATE 7, 25: PRINT USING "###.### MILS PER INCH OF COUPLING LENGTH"; MAXCOLD
LOCATE 8, 25: PRINT USING "###.### DEGREES"; COLDANG: PRINT
LOCATE 10, 18: PRINT "HOT: THE MAXIMUM HOT MISALIGNMENT IS AT THE"
LOCATE 11, 18: PRINT " FLEXIBLE ELEMENT NEAR THE "; HOT$
LOCATE 13, 25: PRINT USING "###.### MILS PER INCH OF COUPLING LENGTH"; MAXHOT
LOCATE 14, 25: PRINT USING "###.### DEGREES"; HOTANG
LOCATE 16, 24: PRINT "OPTIONS ARE:"
LOCATE 18, 24: PRINT "(1) PRINT A COPY OF THE RESULTS"
LOCATE 19, 24: PRINT "(2) DO ANOTHER CALCULATION"
LOCATE 20, 24: PRINT "(3) QUIT THE PROGRAM"
LOCATE 22, 24: COLOR 1, 7: PRINT " SELECT OPTION 1, 2, OR 3 ": COLOR 7, 9

```

CHECK8: K\$ = INKEY\$

```

IF K$ = "1" THEN GOTO PRINTOUT
IF K$ = "2" THEN GOTO MENU
IF K$ = "3" THEN GOTO QUIT
GOTO CHECK8

```

PRINTOUT:

```

CLS : LOCATE 4, 20: PRINT "EQUIPMENT TRAIN IDENTIFICATION"
LOCATE 4, 55: COLOR 1, 7: PRINT " "
LOCATE 4, 55: INPUT " ", TRAIN$
LOCATE 4, 55: COLOR 7, 9: PRINT TRAIN$: PRINT " "

```

```

LOCATE 6, 20: PRINT "DATE ";
LOCATE 6, 27: COLOR 1, 7: PRINT " "
LOCATE 8, 27: INPUT " ", DAT$
LOCATE 6, 27: COLOR 7, 9: PRINT DAT$: PRINT " "

```

```

LOCATE 8, 20: PRINT "COMMENTS": COLOR 1, 7
LOCATE 8, 30: PRINT " "
FOR I = 1 TO 180
PRINT " ";
NEXT I
LOCATE 8, 30: INPUT " ", COMMENTS: COLOR 7, 9
LOCATE 8, 30: PRINT " "
FOR I = 1 TO 180
PRINT " ";
NEXT I
LOCATE 8, 30: PRINT COMMENTS

```

```

LOCATE 13, 20: PRINT "YOUR INITIALS"
LOCATE 13, 38: COLOR 1, 7: PRINT " "
LOCATE 13, 38: INPUT " ", INITIALS$
LOCATE 13, 38: COLOR 7, 9: PRINT INITIALS$: PRINT " "

```

LPRINT " ALIGNMENT RECORD FOR "; TRAIN\$

```

LPRINT : LPRINT
IF TYPE$ = "FR" THEN LPRINT "ALIGNMENT METHOD: FACE & RIM"
IF TYPE$ = "R" THEN LPRINT "ALIGNMENT METHOD: REVERSE INDICATOR"
LPRINT : LPRINT
IF TYPE$ = "FR" THEN LPRINT "THE ALIGNMENT BRACKET IS ON THE "; AS
IF TYPE$ = "FR" THEN LPRINT
IF TYPE$ = "FR" THEN LPRINT "DIAL INDICATOR READINGS ARE TAKEN ON THE "; BS
IF TYPE$ = "FR" THEN LPRINT "THE RIM READINGS ARE AS FOLLOWS (MILS): "
IF TYPE$ = "R" THEN LPRINT "READINGS ON THE "; AS; " (MILS):"
LPRINT
LPRINT " TOP "; TOP1
LPRINT " RIGHT "; RIGHT1
LPRINT " BOTTOM "; BOTTOM1

```

```

LPRINT " LEFT ", LEFT1
LPRINT
IF TYPES$ = "FR" THEN LPRINT "THE FACE READINGS ARE AS FOLLOWS (MILS):"
IF TYPES$ = "RI" THEN LPRINT "READINGS ON THE ", BS, " (MILS):"
LPRINT
LPRINT " TOP ", TOP2
LPRINT " RIGHT ", RIGHT2
LPRINT " BOTTOM ", BOTTOM2
LPRINT " LEFT ", LEFT2
LPRINT : LPRINT
LPRINT "THERMAL GROWTH OF ", AS; TAB(45); AGROWTH; "MILS"
LPRINT "THERMAL GROWTH OF ", BS; TAB(45); BGROWTH; "MILS": LPRINT
LPRINT "DISTANCE BETWEEN FLEXIBLE ELEMENTS": TAB(45); SP; "INCHES"
IF TYPES$ = "FR" THEN LPRINT "FACE READING DIAMETER:"
IF TYPES$ = "FR" THEN LPRINT TAB(45); DIA; "INCHES"
IF TYPES$ = "RI" THEN LPRINT "DIAL INDICATOR SEPARATION:"
IF TYPES$ = "RI" THEN LPRINT TAB(45); SEPARATION; "INCHES"
LPRINT "INDICATOR BRACKET SAG "; TAB(45); SAG; "MILS": LPRINT : LPRINT
LPRINT "COLD ALIGNMENT:"
LPRINT : LPRINT
LPRINT " THE MAXIMUM COLD MISALIGNMENT IS AT THE"
LPRINT " FLEXIBLE ELEMENT NEAR THE "; COLD$: LPRINT
LPRINT USING " ### ### MILS PER INCH OF COUPLING LENGTH "; MAXCOLD
LPRINT USING " ### ### DEGREES "; COLDANG: LPRINT
LPRINT "HOT ALIGNMENT:": LPRINT
LPRINT " THE MAXIMUM HOT MISALIGNMENT IS AT THE"
LPRINT " FLEXIBLE ELEMENT NEAR THE "; HOT$: LPRINT
LPRINT USING " ### ### MILS PER INCH OF COUPLING LENGTH "; MAXHOT
LPRINT USING " ### ### DEGREES "; HOTANG
LPRINT : LPRINT : LPRINT "COMMENTS: "; COMMENTS$
LPRINT : LPRINT : LPRINT : LPRINT
LPRINT "DATE: "; DAT$: " BY: "; INITIAL$: LPRINT CHR$(12)
CLS : GOTO ANSWERS

SPACERTEST:
LOCATE 17, 1
PRINT " WARNING! THIS PROGRAM IS FOR SPACER-TYPE COUPLINGS ONLY,"
PRINT " AND WILL USE 2 INCHES AS THE MINIMUM SPACER LENGTH. IF"
PRINT " THIS IS NOT A VALID ASSUMPTION FOR YOUR APPLICATION, THEN"
PRINT " DO NOT USE THE PROGRAM. (PRESS ANY KEY TO CONTINUE)"

TEST1:
AS = INKEY$
IF LEN(AS) < 1 THEN GOTO TEST1
LOCATE 17, 1:
FOR I = 1 TO 320
PRINT " ";
NEXT I
SP = 2
RETURN

MILCHECK:
IF ABS(TEMP) > .499 THEN FLAG1 = 0: RETURN
IF ABS(TEMP) < .0005 THEN FLAG1 = 0: RETURN
LOCATE 17, 1: FLAG1 = 1: PRINT
PRINT " WARNING! THIS ENTRY MUST BE IN MILS - NOT INCHES. THERMAL GROWTH,"
PRINT " SAG, AND DIAL INDICATOR READINGS MUST BE ENTERED IN MILS"
PRINT " (1 MIL= 0.001 INCHES). ";
PRINT TEMP; " INCHES IS "; INT(1000 * TEMP); "MILS."
PRINT : PRINT " PRESS ANY KEY TO CONTINUE"

TEST2:
KS = INKEY$
IF LEN(KS) < 1 THEN GOTO TEST2
LOCATE 17, 1
FOR I = 1 TO 540
PRINT " ";
NEXT I
IF FLAG2 = 1 THEN GOTO RIMREADINGS
IF FLAG3 = 1 THEN GOTO FACEREADINGS
IF FLAG4 = 1 THEN GOTO REVERSEA
IF FLAG5 = 1 THEN GOTO REVERSEB
RETURN

INSTRUCTIONS:
LPRINT " MISALIGNMENT CALCULATIONS "
LPRINT " ASSUMPTIONS AND DEFINITIONS ": LPRINT
LPRINT "THIS PROGRAM CALCULATES THE MISALIGNMENT OF EQUIPMENT COUPLED WITH"
LPRINT "SPACER-TYPE COUPLINGS WHEN THE EQUIPMENT HAS BEEN ALIGNED USING "
LPRINT "EITHER FACE & RIM OR REVERSE INDICATOR METHODS. IT DOES SO BY "
LPRINT "CALCULATING THE MAXIMUM ANGULARITY OF THE COUPLING SPACER WITH"
LPRINT "EACH OF THE COUPLED SHAFTS. THE MAXIMUM ANGULARITY IS DISPLAYED"
LPRINT "IN BOTH THE COLD (AS-ALIGNED) CONDITION, AND IN THE HOT (RUNNING)"
LPRINT "CONDITION. ANGULARITY IS DISPLAYED IN INCHES PER INCH OF COUPLING"
LPRINT "LENGTH, AS WELL AS DEGREES. ": LPRINT
LPRINT "RECOMMENDATIONS FOR MAXIMUM MISALIGNMENT ARE GIVEN IN A"
LPRINT "NUMBER OF TEXTS AND TECHNICAL PAPERS ON THE SUBJECT.": LPRINT
LPRINT "GENERAL ASSUMPTIONS ARE: ": LPRINT
LPRINT "1) CONVENTIONAL ALIGNMENT BRACKETS ARE USED FOR BOTH THE "
LPRINT " FACE AND RIM AND THE REVERSE INDICATOR METHODS. ": LPRINT
LPRINT "2) CONVENTIONAL ENGLISH UNITS ARE USED; I.E., INCHES FOR"
LPRINT " MACHINE DIMENSIONS, AND MILS (1 MIL=0.001 INCH) FOR DIAL "
LPRINT " INDICATOR READINGS.": LPRINT
LPRINT "3) THERMAL GROWTH OF THE EQUIPMENT IS VERTICAL ONLY, AND"
LPRINT " IT IS UNIFORM AT BOTH ENDS OF THE MACHINE. THERMAL "
LPRINT " GROWTH UPWARD IS POSITIVE; DOWNWARD IS NEGATIVE.": LPRINT
LPRINT "4) THE COUPLING SPACER IS AT LEAST 2 INCHES LONG. IF THE"
LPRINT " USER ENTERS A SPACER LENGTH OF LESS THAN 2 INCHES, A WARNING"
LPRINT " IS DISPLAYED, AND ANY FURTHER CALCULATIONS ARE DONE ON THE "
LPRINT " BASIS OF A 2 INCH SPACER.": LPRINT
LPRINT "5) INDICATOR BRACKET SAG IS THE FULL SAG OF THE BRACKET FROM"
LPRINT " THE TOP POSITION TO THE BOTTOM POSITION AS CHECKED ON A "

```

```

LPRINT " MANDREL. ALTHOUGH THE DIAL INDICATOR IN SUCH A CHECK WILL"
LPRINT " SHOW A NEGATIVE NUMBER, THIS PROGRAM USES THE ABSOLUTE VALUE"
LPRINT " OF THE NUMBER. IF A NEGATIVE NUMBER IS ENTERED, THE PROGRAM "
LPRINT " WILL CHANGE IT TO A POSITIVE VALUE. ": LPRINT
LPRINT "6) FLEXIBLE ELEMENTS OF THE COUPLING ARE ASSUMED TO BE THE "
LPRINT " GEARS, DIAPHRAGMS, DISC-PACKS, ETC. FOR ELASTOMERIC COUPLINGS,"
LPRINT " IT IS NORMALLY CONSIDERED THE DISTANCE BETWEEN SHAFT ENDS.":
LPRINT
LPRINT "7) DIAL INDICATOR READINGS ARE CHECKED FOR CONSISTENCY; I.E., "
LPRINT " TO SEE THAT TOP+BOTTOM=LEFT+RIGHT. IF THE READINGS ARE"
LPRINT " NOT CONSISTENT WITHIN 1.5 MILS, A WARNING IS GIVEN."
LPRINT : LPRINT : LPRINT "ASSUMPTIONS FOR THE FACE AND RIM METHOD.": LPRINT
LPRINT "1) BRACKET SAG AFFECTS RIM READINGS ONLY; NOT FACE READINGS."
LPRINT : LPRINT : LPRINT "ASSUMPTIONS FOR THE REVERSE INDICATOR METHOD.":
LPRINT : LPRINT "1) THE COUPLING SPACER IS CENTERED BETWEEN THE PLANES"
LPRINT " WHERE"
LPRINT " DIAL INDICATOR READINGS ARE TAKEN.": LPRINT CHR$(12)
GOTO MENU
QUIT:
COLOR 7, 8: CLS : END

```

APPENDIX B

The following is a sample printout from the Basic Language program shown in Appendix A.

ALIGNMENT RECORD FOR B-772

ALIGNMENT METHOD: REVERSE INDICATOR

READINGS ON THE BLOWER (MILS):

```

TOP 0
RIGHT 12
BOTTOM 18
LEFT 6

```

READINGS ON THE MOTOR (MILS):

```

TOP 0
RIGHT -2
BOTTOM -10
LEFT -8

```

THERMAL GROWTH OF BLOWER
THERMAL GROWTH OF MOTOR

6 MILS
0 MILS

DISTANCE BETWEEN FLEXIBLE ELEMENTS
DIAL INDICATOR SEPARATION
INDICATOR BRACKET SAG

10 INCHES
12 INCHES
6 MILS

COLD ALIGNMENT:

THE MAXIMUM COLD MISALIGNMENT IS AT THE
FLEXIBLE ELEMENT NEAR THE MOTOR

1.144 MILS PER INCH OF COUPLING LENGTH
0.066 DEGREES

HOT ALIGNMENT:

THE MAXIMUM HOT MISALIGNMENT IS AT THE
FLEXIBLE ELEMENT NEAR THE MOTOR

0.574 MILS PER INCH OF COUPLING LENGTH
0.033 DEGREES

COMMENTS: ALIGNMENT AFTER MOTOR CHANGEOUT

DATE: 10-14-94

BY: HHK

BIBLIOGRAPHY

- Campbell, A. J., "Optical Alignment Saves Equipment Down-time," Oil and Gas Journal (November 1975).
- Campbell, A. J., "The Laser—As Used in Alignment," *Proceedings of the Ninth Turbomachinery Symposium*, Turbomachinery Laboratory, Texas A&M University, College Station, Texas, p. 121 (1980).

- Dodd, V. R., *Total Alignment*, Tulsa, Oklahoma: Petroleum Publishing (1975).
- Dodd, V. R., "Total Alignment Can Reduce Maintenance and Increase Reliability," *Proceedings of the Ninth Turbomachinery Symposium*, Turbomachinery Laboratory, Texas A&M University, College Station, Texas, pp. 123-126 (1980).
- Essinger, J. N., "Hot Alignment Too Complicated?" *Hydrocarbon Processing* (January 1974).
- Essinger, J. N., "Benchmark Gauges for Hot Alignment of Turbomachinery," *Proceedings of the Ninth Turbomachinery Symposium*, Turbomachinery Laboratory, Texas A&M University, College Station, Texas, pp. 127-133 (1980).
- Finn, A. E., "Instrumented Couplings: The What, The Why and The How of the Indikon Hot-Alignment Measuring System," *Proceedings of the Ninth Turbomachinery Symposium*, Turbomachinery Laboratory, Texas A&M University, College Station, Texas, pp. 135-136 (1980).
- Jackson, Charles, "Reverse Indicator Method of Alignment," *Proceedings of the Second International Pump Symposium*, Turbomachinery Laboratory, Texas A&M University, College Station, Texas (1985).
- Jackson, Charles, "Alignment Using Water Stands and Eddy Current Proximity Probes," *Proceedings of the Ninth Turbomachinery Symposium*, Turbomachinery Laboratory, Texas A&M University, College Station, Texas, pp. 137-143 (1980).
- Massey, C. R., and Campbell, A. J., "Reverse Alignment—Understanding Centerline Measurements," *Proceedings of the Twenty-First Turbomachinery Symposium*, Turbomachinery Laboratory, Texas A&M University, College Station, Texas, pp. 189-196 (1992).
- Murray, M. G., Jr., "Reverse-Indicator Alignment and Related Subjects," *Proceedings of the Ninth Turbomachinery Symposium*, Turbomachinery Laboratory, Texas A&M University, College Station, Texas, pp. 145-146 (1980).
- Piotrowski, John, *Shaft Alignment Handbook*, New York, New York: Marcel Dekker, Inc. (1986).

ACKNOWLEDGMENT

The author gratefully acknowledges the generous contributions of the many craftsmen, craft foremen, factory service personnel, mechanical inspectors, engineers, and others who have shared their alignment experiences and expertise over many years. His personal thanks to each one. Hopefully, the material in this paper represents them well.