



## LEAKAGE DETECTION AND CONTAINMENT IN ARRANGEMENT 1 SEALS

**Michael Huebner**  
Principal Engineer  
Flowsolve Corporation  
Deer Park, Texas, USA



*Michael Huebner is a Principal Engineer at Flowsolve Corporation in Deer Park, TX. He has over 30 years of experience in pumps, seals and fluid handling equipment. Mr. Huebner is a member of the API 682 Task Force, the ASME B73 Committee and the Texas A&M Pump Users Symposium Advisory Committee.*

### ABSTRACT

Mechanical seals are the most common means of sealing industrial centrifugal pumps. There are a wide variety of seal options including the use of single or dual seal arrangements. While dual seals provide benefits in leakage containment and monitoring, single seals continue to be widely used due to their lower cost and simpler designs. Newer piping plans however offer options to increase leakage detectability and containment in single seals without sacrificing the simplicity of the seal design.

A Plan 65 piping plan was introduced in API 682 Third Edition and ISO 21049. This captured leakage detection practices which were currently in use in the pipeline industry. The upcoming Fourth Edition of API 682 changes the designation of this plan to Plan 65A and adds an alternative version designated as Plan 65B. In addition, the Fourth Edition of API 682 will introduce Plan 66A and 66B which provide additional alternatives for monitoring and containing seal leakage in the seal gland.

The selection of piping plans in any seal application depends not only on the application conditions but also on the expectations of the end user. This includes the design of the pump and also the infrastructure to monitor equipment performance and handle process leakage. With these new options for piping plans, end users can add additional capabilities to their existing Arrangement 1 seal installations and consider single seals for future applications.

### INTRODUCTION

Mechanical seals continue to be the most common method for sealing centrifugal pumps in the petroleum, petrochemical, and chemical industries. These seals have proven to provide reliable operation and meet environmental regulations across a wide variety of application conditions and pump designs. A mechanical seal is not, however, a single design. Over the

years, seal OEMs have developed literally hundreds of seal models. These designs have been tailored to meet specific operating conditions including extreme variations in pressures, temperatures, and speed.

While mechanical seals are available in a wide variety of designs, they are supported by an equally wide variety of piping plans and seal support systems. They are also available in single or multiple seal arrangements. The selection of a seal type, seal arrangement and piping plan is a function of not only the operating conditions but also the user's expectations on monitoring seal performance and leakage containment.

### SEAL ARRANGEMENTS

A single mechanical seal continues to be the most commonly applied seal design in centrifugal pump applications. There are, however, applications where a single seal cannot meet the performance expectations of the user. In some cases the consequences of seal leakage may be unacceptable. This may require the redundancy provided by dual seals. There are other applications where the operating conditions or the pumped fluid is not suitable for reliable seal operation. In these cases, multiple seals and external fluids have been utilized to achieve the required results.

API 682, Pumps - Shaft Sealing Systems for Centrifugal and Rotary Pumps, has defined three common seal arrangements which detail the number of mechanical seals and their use of buffer and barrier fluids. These are the most common arrangements used in industry today although other variations (such as triple seals) are used in some specialized applications. The selection of a seal arrangement requires a careful consideration of the advantages and limitations of each option and their ability to meet the user's requirements.

#### *Arrangement 1*

Arrangement 1 defines the use of one mechanical seal in a seal chamber (Figure 1). Historically, this has also been called a single seal. The seal contains one set of seal faces and the seal is exposed to fluid in the pump seal chamber. While various piping plans are available to modify the environment in the seal chamber, the mechanical seal's primary objective is to minimize the amount of process fluid in the seal chamber from reaching the atmospheric side of the seal. Under normal operation, a very small amount of process weepage will exit the seal.

Arrangement 1 seals continue to be the most commonly

applied arrangement due to their lower cost and simplicity. In most cases, the seals can be applied with a simple piping plan (e.g. Plan 11) and do not require the operator to monitor or maintain the seal or sealing system. Arrangement 1 seals are also generally small in physical size and can fit into virtually any centrifugal pump design.

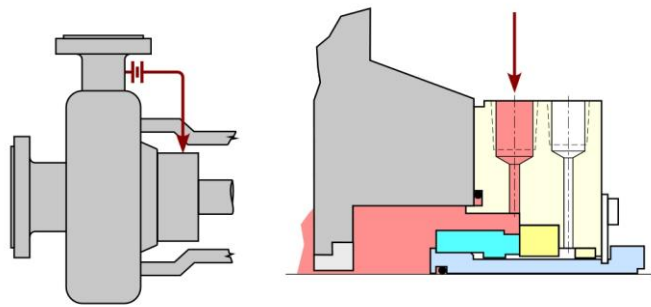

**Figure 1 Arrangement 1 Mechanical Seal**

*Arrangement 2*

Arrangement 2 seals are designed with two mechanical seals in series (Figure 2). The inner seal is designed to seal the fluid in the seal chamber. Any leakage past the inner seal will flow into a cavity between the two seals. This cavity is normally filled with a buffer fluid which is maintained at a pressure lower than seal chamber pressure. The outer seal is designed to normally seal the buffer liquid (and any accumulated process leakage) under low pressure conditions. If the inner seal fails, the outer seal is designed to operate under the full pressure and temperature conditions of the seal chamber. In this way, the Arrangement 2 seal provides full redundancy in case of inner seal failure.

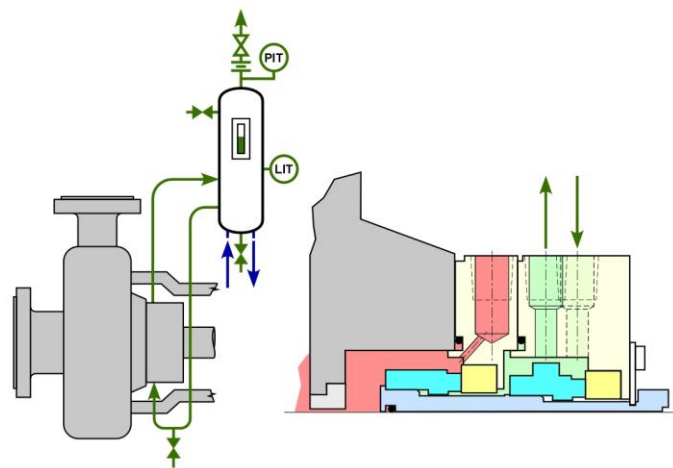

**Figure 2 Arrangement 2 with Liquid Buffer Fluid**

Containment seals provide another common option for Arrangement 2 seals designs (Figure 3). The outer seal, designated as a containment seal, is designed to operate as a dry running seal without the need for any liquid lubrication. A containment seal will normally operate under low pressure

conditions for the majority of its life. If the inner seal fails however, the containment seal will prevent excessive leakage from reaching the atmosphere. There are several standard piping plans which help support the use of these Arrangement 2 configurations (e.g. Plans 72, 75, and 76).

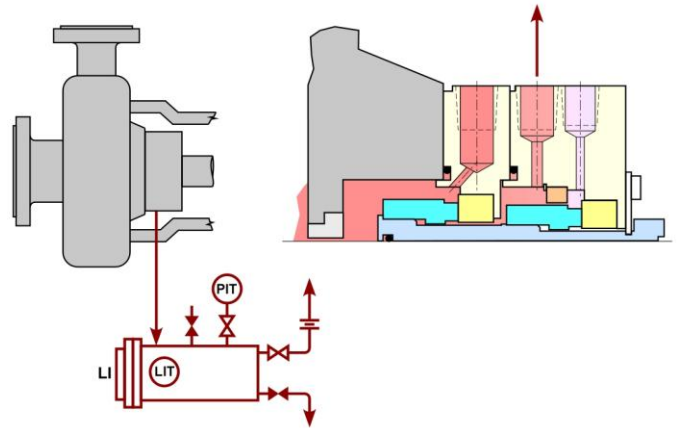

**Figure 3 Arrangement 2 with Containment Seal**

One obvious benefit of an Arrangement 2 seal is the redundancy of providing two seals. If either the inner or the outer seals fails, the seal design will be able to contain the process fluid. Another benefit is that a properly designed seal support system will allow the operator to monitor the seals performance with the instrumentation in the piping plan. For liquid buffer fluids, a Piping Plan 52 will allow the user to monitor liquid phase leakage through a level transmitter or vapor phase leakage through a pressure transmitter. For Arrangement 2 seals with a containment seal, vapor phase process leakage is monitored with a pressure transmitter and liquid phase leakage is monitored by a level transmitter in a leakage collection reservoir.

Both of these options require more sophisticated seal support systems than an Arrangement 1 seal. Liquid buffer fluids will require a seal reservoir to contain, cool, and monitor the buffer fluid. This may require external utilities such as cooling water. Containment seal configurations may require the use of external buffer gas flush. Both of these options require connecting the seal support system to a process leakage disposal system such as a flare or recovery system. The seal support systems, while reliable, do require attention in proper design, installation, commissioning, operation, and maintenance to ensure adequate seal performance.

*Arrangement 3*

Arrangement 3 seals are defined as two mechanical seals with the barrier fluid between the seals maintained at a pressure higher than the seal chamber pressure (Figure 4). In this arrangement, both the inner and outer seals are sealing the barrier fluid. This makes the seal less dependent on the fluid properties of the process fluid in the seal chamber. The seal can even be operated without any liquid in the seal chamber. Another benefit of this arrangement is that no process leakage will migrate to the atmosphere since the barrier fluid is

maintained at a higher pressure than the seal chamber pressure. Barrier fluid will leak across the inner seal into the process and across the outer seal to the atmosphere.

The selection of a barrier fluid is critical in these applications since it will leak into the process. It must be compatible with the process fluid and not create any complications with downstream process operations in the plant or negatively impact pump performance. In addition, the barrier fluid must be environmentally acceptable since small amounts of leakage will migrate to the atmospheric side of the outer seal.

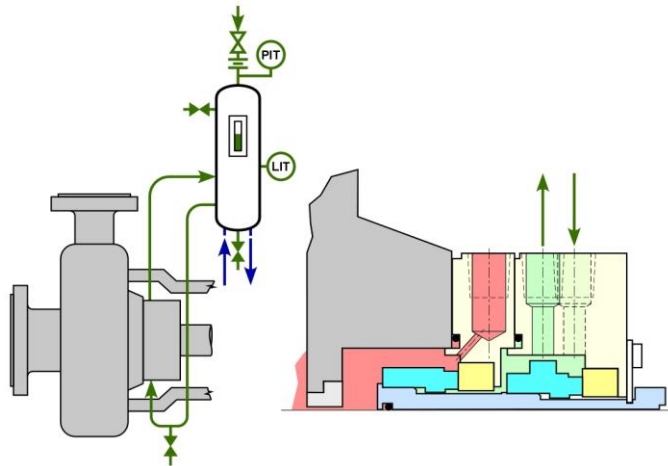

**Figure 4 Arrangement 3 with Liquid Barrier Fluid**

The real complication of an Arrangement 3 seal design comes from creating the higher pressure required by the barrier fluid. There are several piping plans which describe common methods for pressurizing barrier fluids such as Plan 53A, 53B, and 53C. Each of these piping plans not only creates the required pressure but they also provide a means for monitoring the loss of barrier fluid (seal leakage). This is accomplished by monitoring the liquid level or pressure decay in the system depending upon the piping plan. In addition, the sealing systems provide a means of cooling the barrier fluid through integral or external seal coolers. As an additional option, engineered support systems defined as Piping Plan 54 can provide a virtually unlimited set of options to monitor, condition, and circulate the barrier fluid for one or more mechanical seals.

Seal systems which support Arrangement 3 seals are generally the most complex systems for seal applications. The number of components, the requirement to pressure the systems, and the need to maintain barrier fluid levels make these the most operator intensive seal systems. Depending on the piping plan, external pressurization sources (most commonly, Nitrogen) must be available. Other external utilities such as cooling water may be required. Arrangement 3 seal systems provide some unique benefits but also have some unique demands on the operators of the equipment.

In addition to Arrangement 3 seals with liquid barrier fluid systems, Arrangement 3 seals can be provided with gas barrier fluid systems (Figure 5). These are commonly referred to as dual gas seals. While dual gas seals offer some unique benefits

and require an arguably simpler support system, they do require a constant connection to a barrier gas supply system. The reliability of the seals is often tied more to the reliability of gas supply system than to the pump operation. This reliance on the barrier gas supply system also limits its use in remote locations.

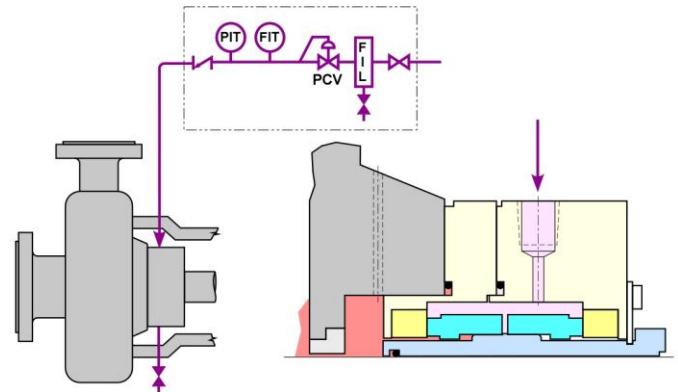

**Figure 5 Arrangement 3 with Gas Barrier Fluid**

In selecting the appropriate seal design and arrangement, the operator must consider all of the strengths and limitations of these options. Arrangement 1 seals provide a simple, cost effective sealing solution with a limited ability to control and detect excessive leakage. Arrangement 2 seals capture process leakage and allow for leakage monitoring at the expense of a more complex support system, external utilities and operator intervention. Arrangement 3 seal provide excellent product isolation and leakage monitoring often with the most complex support systems, use of external utilities, and required operator maintenance.

There are some existing and new piping plans which can expand the use of Arrangement 1 seals by addressing some of their limitations. This may allow users to consider upgrading their current Arrangement 1 seals rather than switching to a dual seal solution. It may also allow users to specify Arrangement 1 seals in new applications where the capabilities of the new piping plans will meet the application requirements. Before examining these options, it is informative to consider leakage paths of process fluids during the failure of an Arrangement 1 seal.

#### **LIMITATIONS OF MONITORING AN ARRANGEMENT 1 SEAL**

As previously stated, a mechanical will have a small amount of sealed fluid weep across the seal faces. This small amount of leakage is a function of the seal size, the differential pressure, and the operating speed. It can also be a function of the fluid properties of the process as well as the condition and operation of the equipment it is installed in. In many cases, this leakage is small enough to meet environmental regulations and housekeeping requirements of the user. The real challenge comes when the seal fails.

A mechanical seal is designed to provide many years of reliable operation. In the refinery industry today, mechanical seals routinely operate for six to ten years in equipment which

is properly maintained and operated. Mechanical seals, however will eventually fail. In most cases, this is due to a degradation of the centrifugal pump, operation of the pump in a manner detrimental to the seal, or a degradation of the seal due to the operating environment. In any case, the seal leakage will generally increase until the seal no longer meets the requirements of the user. In this case, the seal must be removed and replaced.

There are several common options for detecting the failure of an Arrangement 1 seal. In most cases, non-volatile (liquid phase) leakage is visually monitored by the operator. The operator on scheduled rounds will notice that there is a visual drip from the seal or an accumulation of leakage under the pump on the baseplate. If the leakage rate is low, the operator may continue to allow the pump to operate and monitor the leakage over time. If the leakage rate is large, the operator will schedule the pump for maintenance or shut down the equipment depending upon the magnitude and consequences of the leakage.

Volatile (vapor phase) leakage will require the use of instrumentations such as an organic vapor analyzer (OVA) to measure the concentration of process vapors in the environment immediately outside the mechanical seal. If the concentration is too high, the user may wash down the equipment and retest to get a more accurate reading. If the monitoring continues to detect a high concentration, the equipment will be scheduled for maintenance.

Both of the above examples have one significant limitation – they require that an operator is actively engaged in monitoring the equipment. There must be an operator physically present with their attention focused on the mechanical seal. This is difficult in even the most ideal situations. This is particularly challenging if the plant is experiencing upsets or the operator's attention is required in a different area. In some cases, centrifugal pumps are located in remote areas within a plant (e.g. tank farm) or even in remote locations away from a major facility (e.g. unmanned pipeline stations). There may be several days between times when an operator has the opportunity to visually inspect a seal for leakage. If the leakage rate is low, this may be acceptable. If the leakage rate is high, this may have unacceptable consequences.

## LEAKAGE SCENARIO WITH AN ARRANGEMENT 1 SEAL

Under normal operating conditions, an Arrangement 1 seal will have a small amount of weepage which will migrate across the seal faces. Most Arrangement 1 seals are designed with features which will direct liquid phase leakage to a port at the bottom of the seal gland. The drain port is normally machined into the outer diameter of the seal gland and is located at the lowest point (6:00 o'clock position). In this location, liquid phase leakage will drain by gravity to the drain port and exit the gland. In most horizontal centrifugal pumps, the area under the seal gland is occupied by the pump bracket (or bearing bracket.) Because this area is normally obstructed, there is often no piping or tubing connected to the drain port and leakage simply falls from the gland into the pump bracket.

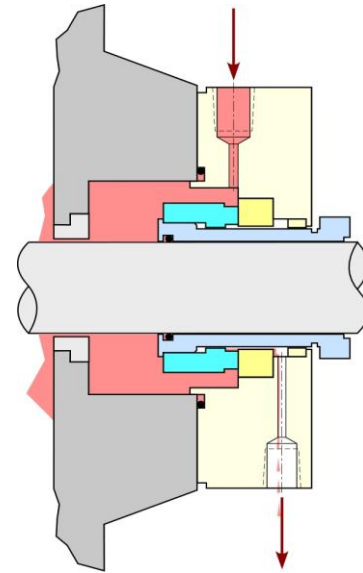
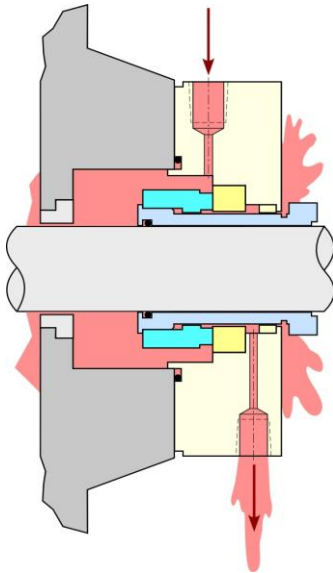

**Figure 6 Minor Leakage from Arrangement 1 Seal**

A properly operating seal will have relatively consistent leakage rates over the majority of its life. There are some variations which can result from changes in operating conditions but overall leakage rates should not vary significantly. As a seal reaches the end of its life, however, the leakage rates will increase as the components in the seal wear out or are negatively impacted by the operation of the equipment.

The progression of a seal failure will depend entirely upon the failure mechanism. If the failure is caused by a gradual process (e.g. wear), the leakage rate may increase over time as a component loses the ability to perform its function. This will be termed a progressive failure. A progressive failure is one in which the leakage rate can be trended over time and provides the user with the opportunity to react to the seal failure before the leakage rate becomes too high. Many of the current methods of monitoring seal performance are predicated on a progressive failure scenario.

It is not uncommon, however, to have a seal failure where the leakage rate increases rapidly. This could be caused by a component “instantly” losing the ability to perform its function. Examples include a component hanging up or fracturing. These may be tied to a failure of another component in the support equipment or host equipment such as a bearing failure or shaft breakage in a centrifugal pump. In these cases, the leakage rate may become unacceptably high almost instantly. This will be termed an instant failure. An instant failure would not provide the end user with the ability to predict or prepare for the failure. If the seals are located in a remote area, this could result in a delay in reacting to the excessive leakage.



**Figure 7 Excessive Leakage from Arrangement 1 Seal**

**PIPING PLANS FOR LEAKAGE DETECTION IN ARRANGEMENT 1 SEALS**

Containing, collecting, and monitoring leakage which exits the seal gland provides an opportunity to alarm the user of a seal failure. As stated earlier, the area around the mechanical seal is commonly defined by the centrifugal pump and any leakage collection strategy must consider the pump construction. Some pumps are designed with the capability to collect process leakage from packing or a mechanical seal and provide connections to drain the leakage from this bracket area (Figure 8). This is especially common for large, between bearing pumps (Figure 9). In these pump designs, users often install splash shields around the seals to minimize leakage from spraying or splashing out of the bracket area. This also directs the process fluid to the bracket and the drain system to improve leakage detection.

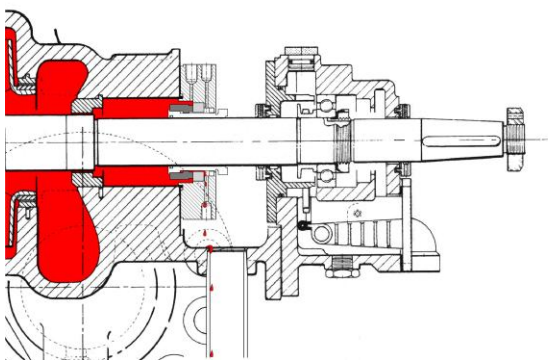

**Figure 8 Mechanical Seal Installed in Pump with Drain from Pump Bracket**

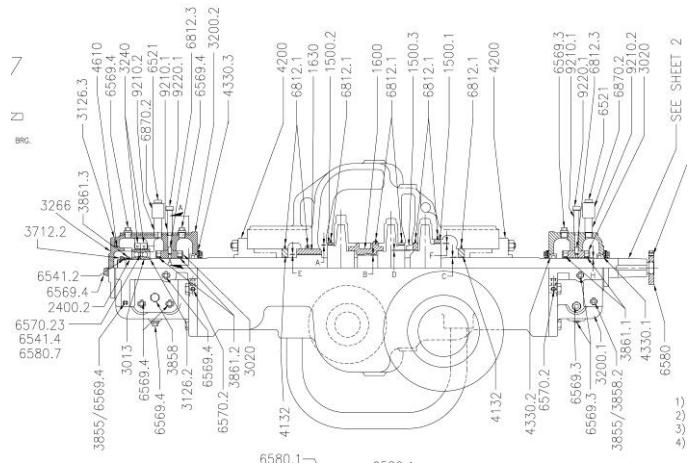
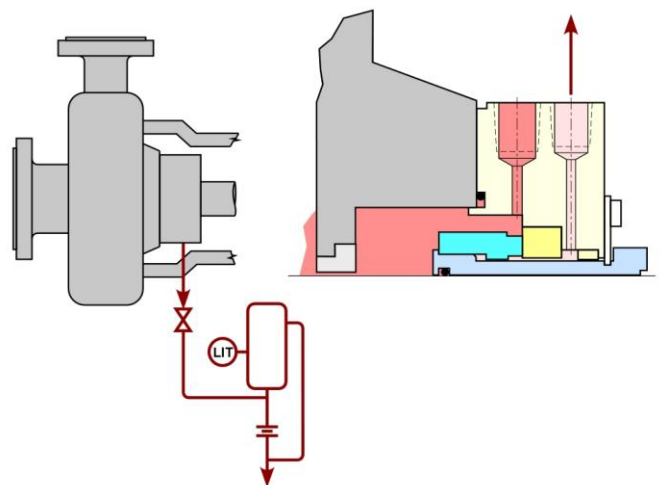

**Figure 9 Example of Between Bearing Centrifugal Pump**

While the collected liquid phase leakage is now in a drain or collection system, there is still a challenge with instrumenting the system to detect a seal failure. A standardized piping plan for this task was introduced in API 682 Third Edition and was designated as Piping Plan 65. In API 682 Fourth Edition, another variation of this piping plan was added so now both a Plan 65A and Plan 65B are available. In API 682, Plan 65A and Plan 65B are both considered technically equivalent. There are however significant differences in their detection strategy so one may be more appropriate for a specific application,

**Plan 65A**

Plan 65A is the most commonly used piping plan for detecting atmospheric seal leakage of liquid phase process fluids (Figure 10). This plan was originally developed in the pipeline industry as a method of detecting seal failures in remote or unmanned pipeline stations and was used for many decades even before it was officially defined in API 682. It is still the most commonly used piping plan for this purpose in the pipeline industry. It has however seen more limited applications in the more general pump industries.



**Figure 10 Piping Plan 65A**

The function of the Plan 65A system is relatively simple. Leakage from the seal is collected in the drain line and flows to a collection system or sump. This flow is restricted by an orifice in the drain line. Low flow rates easily flow across this orifice without increasing the upstream level. As the flow rate increases however, the upstream level increases. The level increase is monitored in a detection vessel installed in the Plan 65 piping system. The original Plan 65 description defined the use of a level switch to alarm at a specific level in the detection vessel. The newer definition of a Plan 65A defines the use of a transmitter to continuously monitor the upstream level. If the leakage rate continued to increase, the system contains a bypass to allow leakage to go around the orifice and prevent the level from backing up to the pump bracket.

While this piping plan has been in common use, there has been no standardization as to the designing of the detection vessels, the connection to the pumps, or the interconnecting piping. The P&ID of the piping plan gives an overview of the function of the plan. The actual implementations in the field have significantly different designs.

Focusing on the detection vessel, a field survey showed installed vessels which ranged from homemade “tin cans” with a simple lid sitting on top to highly engineered pressure vessels which were commercially purchased. The quality of the construction was not the only variation. The actual design of vessel and its connection to the interconnecting piping can be different. This could lead to confusion when installing the system in the field. Examples of some of typical variations are shown below (Figures 11 – 14).

Piping Plan 65 systems are often considered a permanent part of the pump and piping system. This is supported by the fact that the system is permanently connected to the pump and drain or sump systems. For this reason, the Plan 65 systems are often installed with the original pump installation and piping decisions are often made without input from the seal OEM. In most applications, a separate detection vessel is connected to each end of the pump. In some applications however, the piping from both end of the pump are connected to single vessel. In some applications, the vessel is located immediately adjacent to the pump while others have the vessel some distance away. Some vessels are mounted at the same elevation of the foundation of the pump while others will be located significantly lower at ground level.

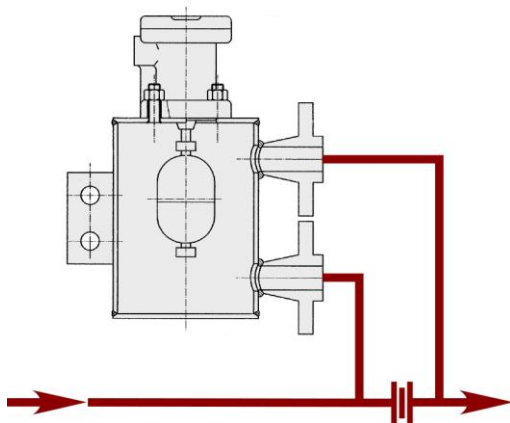

**Figure 11 Example of Piping Plan 65 Detection Vessel**

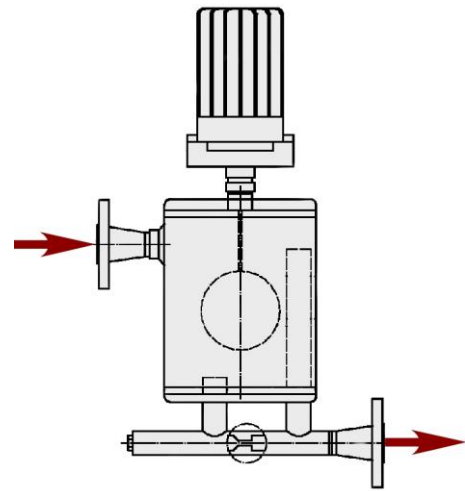

**Figure 12 Example of Piping Plan 65 Detection Vessel**

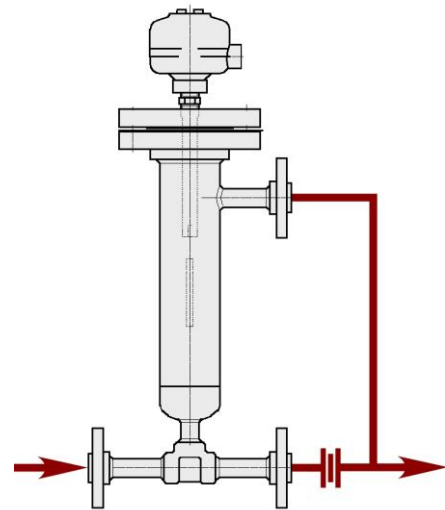

**Figure 13 Example of Piping Plan 65 Detection Vessel**

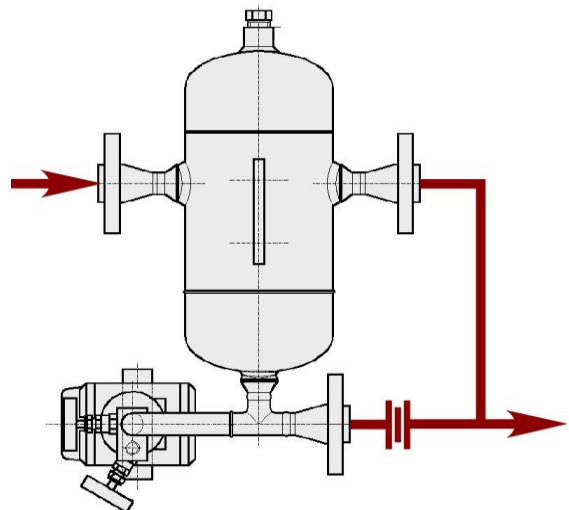

**Figure 14 Example of Piping Plan 65 Detection Vessel**

All of these variations have made it impossible to categorically predict the performance of Plan 65A system. Differences in vessel design (especially alarm levels), orifice sizes, and installed elevations make it impossible to make generalized statements about the leakage rate required to trigger an alarm. It is however quite straightforward to determine the performance of a specific installation. End users should consider standardizing on Piping Plan 65A designs to allow for a more consistent interpretation of alarm levels or transmitter readings.

API 682 Fourth Edition introduces some definitions and guidelines for the design of the detection vessel. Since, in some installations, the detection vessel may be directly connected to the seal gland, it is possible for the vessel to be exposed to pump operating pressure. For this reason, API 682 requires that the vessel be considered part of the pressure boundary. The vessel shall have a volume of at least 0.75 gallons (3 L) and be fabricated from schedule 40 piping.

Since these systems have been in common use for many decades, there are some excellent lessons learned from industry. Flow of process leakage from the pump to the collection system is gravity induced. This requires an appropriate change in elevation (detection vessel located lower than the seal gland or pump bracket) and continuous slope in the drain line. The condition of the process fluid in the Plan 65A system must also be considered for all ambient conditions. In some cases, process fluids may solidify or freeze in the lines or vessel resulting in plugging. It is very common for these systems to be heat traced in colder climates. Since many of the pump brackets are open to atmosphere, insects or other debris may enter the drain piping, plug the orifice and result in a false alarm. The user should avoid installing screens or other barriers in the piping since plugging of the screen would prevent leakage from reaching the detection vessel and render the Plan 65A inoperable.

#### Plan 65B

In the Piping Plan 65A discussed above, the system is designed to monitor on seal leakage rates. Higher leakage rates develop an increase in the level upstream of the orifice. It was also stated that it is impossible to generalize about the correlation between a specific alarm point or level reading in a detection vessel and the actual flow rate. In addition, at very low flow rates, the leakage will easily flow across the orifice with no level increase making it impossible to monitor these flow rates in a Plan 65A. Piping Plan 65B offers an alternative which addresses these limitations.

A Piping Plan 65B is schematically identical to a Plan 65A with the exception that the orifice in the drain line is replaced with a normally closed block valve (Figure 15). In this system, any leakage that flows into the Plan 65 will be blocked by the valve and will increase the level upstream of the valve. The leakage will accumulate and will increase the level in the detection vessel. This will allow the user to monitor the accumulated leakage over time with a level transmitter. By monitoring rate of change in the level, the user can determine the leakage rate of the seal.

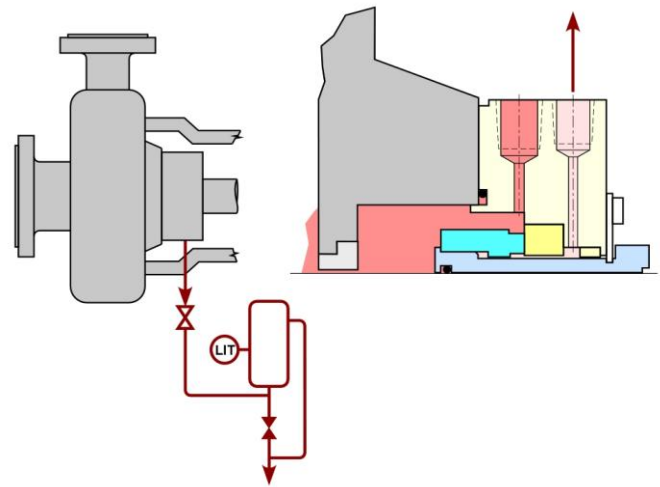

**Figure 15 Piping Plan 65B**

While there is a benefit to capturing and tracking all of the leakage, there is drawback that the detection vessel has a limited volume. The level will increase until it reaches a by-pass level. At this point, the system will stop accumulating incremental leakage and the level indicator will remain steady at the high level position. To prevent this from occurring, the operator will set a high level maintenance alarm at a level lower than the by-pass. When the process level reaches this level, an alarm will notify the operator that it is necessary to open the block valve and drain the detection vessel. By noting the rate of change on the transmitter readings or by monitoring the frequency of draining, the operator can determine the performance of the seal.

In addition, the operator may want to set a high-high level alarm between the high level alarm and the by-pass level. If the level is increasing so quickly that the high-high level is reached prior to operator draining the detection vessel, the leakage rate is likely high enough to indicate a seal failure.

One of the benefits of a Plan 65B is that the operator can determine real (or average leakage) leakage rates over time. To do this, the changes in volume of the detection vessel and connecting piping must be correlated to the changes in the transmitter readings. This is relatively straightforward. The design of the detection vessel will obviously have an impact on the total system volume which will affect time intervals between draining the system. The design will also affect the sensitivity of the leakage rate detection with a smaller diameter detection vessel being more accurate than a larger diameter vessel.

The Plan 65B is a new piping plan and has limited usage in the field. As with any changes in detection strategy, new users will develop their own processes and procedures for setting alarm points and maintaining the equipment.

Plan 65 systems (especially Plan 65A) have proven to adequately detect leakage of Arrangement 1 seals in remote locations. There are several significant considerations though when you evaluate these plans. In most cases, the leakage of the mechanical seal will have migrated out of the seal gland and into the pump bracket. The fluid level in the pump bracket will increase as the leakage rate increases. The process leakage will flow by gravity into the interconnecting piping between the

pump bracket and the detection vessel. High flow rates or high accumulation levels in the detection vessel will signal a seal failure. If there is progressive seal failure (gradual increase in leakage over time), this strategy is usually successful.

Instant seal failures which result in a very high level of leakage however can be difficult to detect quickly enough to prevent leakage from reaching to the ground or contaminating the pump bearing housings. If the leakage rate from the seal is higher than the gravity induced flow into the Plan 65 piping system, the level in the pump bracket will increase until it overflows the bracket. Depending upon the pump construction and bearing isolators, this can also result in process fluid entering the bearing housing (Figure 16) and contaminating the pump lubrication system. This can occur more quickly than the Plan 65 system can detect the failure and the operator can stop and block-in the pump.

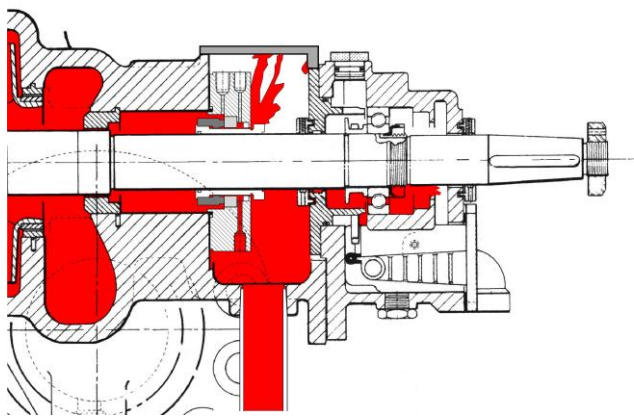

**Figure 16 Illustration of High Levels of Process Leakage in Pump Bracket**

Plan 66A

Piping Plans 66A and 66B address some of the limitations of the Plan 65 systems and introduce new capabilities for Arrangement 1 seals. The strength of the Plan 66 piping plans are that they are designed to reduce the leakage rate leaving the seal gland in the event of seal failure. In addition, they provide an ability to monitor seal leakage more accurately than other methods. The plan can also be designed to work on both liquid phase and vapor phase leakage. One of the unusual aspects of this piping plan is that it is contained entirely in the seal gland and does not require any external piping or auxiliary equipment.

In a traditional Arrangement 1 seal, leakage which goes between the seal faces migrates axially into a cavity between the seal faces and the bushing. This same cavity is the location for the quench and drain ports on the seal gland. This will be designated as the drain cavity. When small quantities of process leak into the drain cavity, they flow by gravity out of the drain port. The drain port is left open to allow an easy egress for this fluid.

The drain cavity also contains a bushing which helps separate the drain cavity from atmosphere. This bushing is

designated as the throttle bushing. The function of the throttle bushing is to limit seal leakage from leaving the end of the seal gland and direct it out of the drain port. This minimizes the amount leakage which could potential spray out of the gland and create environment, safety, and housekeeping concerns. To minimize this leakage, mechanical seal assemblies use a variety of throttle bushing designs. These range from fixed bushings to floating bushings to segmented bushings. These options allow the seal designer to create the level of restriction appropriate for the application.

If there is a very high level of leakage, the drain cavity will be flooded with process fluid. If we assume the extreme case that the mechanical seal provides no restriction to the process fluid, the drain cavity could theoretically be exposed to the seal chamber conditions. In this case, there is a potential for a high rate of leakage to leave the seal gland at both the throttle bushing and the drain port. This is the leakage which would normally be captured in a Plan 65 system in a conventional seal design.

A seal designed for Piping Plan 66A changes this failure scenario through the addition of one component – an additional bushing. In this plan, there is a highly restrictive bushing located between the seal faces and the drain cavity (Figure 17). As low flow rates of process leakage leave the seal faces, they flow easily across the inner bushing with little restriction. The leakage flows into the drain cavity and leaves the seal gland. As the leakage rate increase, the inner bushing begins to restrict the flow rate and minimize leakage entering the drain cavity. This has the effect on minimizing seal leakage leaving the seal gland. A by-product of this restriction is an increase in pressure in the cavity between the seal faces and the inner bushing. This cavity will be instrumented with a transmitter to monitor pressure and, indirectly, seal leakage.

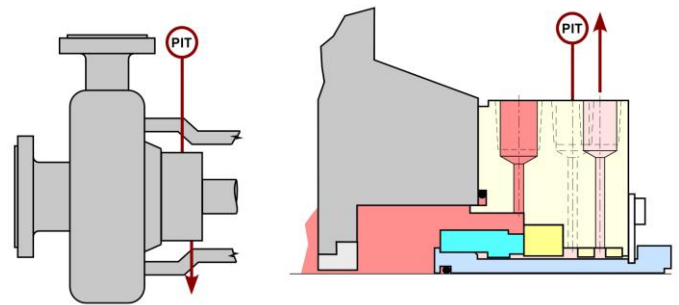

**Figure 17 Piping Plan 66A**

If we assume the previous extreme failure mode, the seal chamber operating conditions would only exist upstream of the inner bushing (Figure 18). Any leakage which flowed past this bushing would enter the drain cavity at a significantly lower pressure and be further restricted by the drain port and outer bushing. This series application of restrictions can reduce the leakage leaving the seal gland below that which is possible with a conventional design. It is also obvious that the inner bushing will be most effective if it provides the greatest restriction. For this reason, a segmented bushing would be considered the optimal solution from a leakage management perspective.



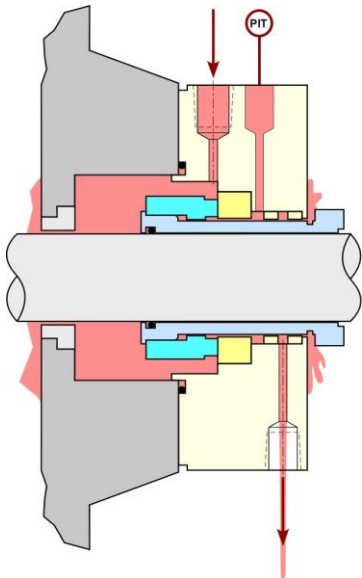

**Figure 18 Piping Plan 66A Leakage Paths**

The use of a pressure transmitter to monitor seal leakage in this manner is a relatively new concept and has had only a few end users with significant experience. Whenever a new parameter is measured, there is always a learning curve in collecting the data and interpreting its significance. This will certainly be the case in Plan 66 systems.

When a centrifugal pump is started, there are a few seconds of relative instability as the shaft becomes radially centered and is thrust into a stable axial position. There may be thermal expansion effects in the pump as the pump and process temperatures stabilize. The mechanical seal will also go through pressure and thermal transitions as it changes from a state of rest to steady-state operation. These transitions are normally accompanied by an increase in leakage immediately after start-up. After several minutes of operation, the pump and seal systems, along with the seal leakage rate, stabilize. One end user stated that they put a time delay on the pressure transmitter leakage alarm for several minutes after start-up to prevent false alarms.

Plan 66A designs potentially have some limitations which should be considered. Seal leakage will be present in the cavity between the seal faces and inner bushing. If the fluid is non-flashing, there will be a small amount of liquid trapped in this area even during normal operation. If the process fluid contains solids which may collect in this region or will otherwise polymerize or solidify under atmospheric conditions, the user should consider using a Plan 66B or other seal arrangement.

#### Plan 66B

A Plan 66B is a variation of the Plan 66A without the inner bushing. This piping plan attempts to deliver some of the same benefits as the Plan 66A in a smaller, simpler design. A Plan 66B is very simply a conventional Arrangement 1 seal design with the addition of an orifice plug installed in the seal gland (Figure 19). This orifice plug (a solid plug drilled with a specific diameter though hole) acts to minimize leakage from

exiting the seal gland through the drain port. The throttle bushing must be very restrictive and should ideally be a segmented bushing design. Plan 66Bs also uses a pressure transmitter in the drain cavity to monitor pressure and indicate seal leakage.

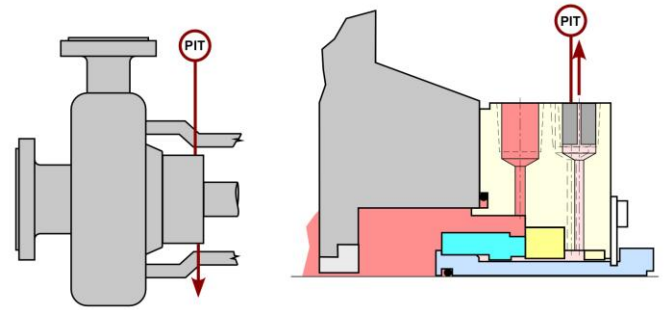

**Figure 19 Piping Plan 66B**

In the event of our extreme failure scenario, a complete seal failure could expose the drain cavity to seal chamber conditions. In this case both the throttle bushing and the orifice plug will see full pressure. This will result in higher leakage rates than would be seen in a corresponding Plan 66A. In addition, A Plan 66B will also be less sensitive to detecting leakage since the combined restrictions of a parallel flow through the throttle bushing and orifice plug will be less than through the single bushing in a Plan 66A.

Plan 66B designs however do have some advantages to Plan 66A. A Plan 66B can be installed directly on many existing Arrangement 1 seals in the field with minimal modifications to the hardware (upgrade to throttle bushing). The Plan 66B seal design requires the same axially length as a conventional seal design. The drain cavity is also open which allows for complete drainage of the process fluid from the seal gland.

## CONCLUSIONS

While Arrangement 1 seals continue to be commonly used throughout industry, few end users are aware of the potential to expand their capabilities through the use of new piping plans. While Arrangements 1 are recognized for their simple design and reliable operation, they are not recognized for their ability to allow for containment and monitoring of seal leakage. Piping Plan 65A provides a proven manner to monitor seal leakage rate through an external detection vessel. This is expanded through a Plan 65B to provide monitoring of accumulated leakage. Plan 66A represents a new paradigm in monitoring seal leakage in the seal gland and preventing high levels of leakage from exiting the gland. A Plan 66B represents a slightly less effective option but provides easier retrofitting into existing seal hardware.

No piping plan or sealing solution should however be selected solely on its capabilities. It must be considered in light of the end user's leakage containment requirements, their needs to monitor or alarm on seal leakage, and the design of the host equipment. These new piping plans do however expand the options available to improve the performance of both new and existing Arrangement 1 seal installations.

## **REFERENCES**

- API Standard 682, Second Edition, 2001, "Pumps – Shaft Sealing Systems for Centrifugal and Rotary Pumps," American Petroleum Institute, Washington, D.C.
- API Standard 682, Third Edition, 2004, "Pumps – Shaft Sealing Centrifugal and Rotary Pumps," American Petroleum Institute, Washington D.C
- Huebner, M. B., Buck, G. S., Azibert, H. V., 2012, "Advancement in Mechanical Sealing – API 682 Fourth Edition," Proceeding of the Twenty-Eighth International Pump Users Symposium, Turbomachinery Laboratory, Texas A&M University, College Station, Texas

## **ACKNOWLEDGEMENTS**

The author would like to acknowledge the contributions of the API 682 Task Force in developing and maintaining the piping plans standards for industry over the years. Special recognition goes to Rick Eickhoff for his leadership during the development of the Fourth Edition of API 682. He would also like to acknowledge the support of Scott Svendsen and Flowserve Corporation for the support in preparing this paper.