

DESIGN AND DEVELOPMENT OF GAS LUBRICATED SEALS FOR PUMPS

by

James R. Wasser

John Crane Inc.

Morton Grove, Illinois

Rick Sailer

and

Greg Warner

G.E. Plastics

Mount Vernon, Indiana



James R. Wasser is a Senior Mechanical Engineer in new product development with John Crane Inc., located in Morton Grove, Illinois. He received his B.S. in Mechanical Engineering from Illinois State University (1985). Before John Crane, he worked at Magenta Corp., a custom molder of thermoplastics, as a Design Engineer. He has been with John Crane for seven years and has been working on the design and application of dry sealing technology for over five years.

He has written papers for STLE and RO-CON. He is a member of STLE.

Rick Sailer is a Senior Mechanic in the Maintenance Group of GE-Mt. Vernon Manufacturing. He is responsible for the daily and preventative maintenance of two chemical operation plants which include over 150 pieces of rotating equipment with seals. Mr. Sailer has been credited with development and modification of seal designs which have provided the chemical operation plants with onstream time of 99.9 percent.



Greg Warner is a Senior Engineer in the Project Engineering Group of GE-Mr. Vernon Manufacturing. He received a BSChE from University of Missouri-Rolla. Greg has 20 years of multi-function experience in the areas of manufacturing operations, chemical process design, project management, and plant startups. Responsibilities include new technology into chemical process plant applications and project management.

centrifugal pumps is discussed. The applications are hot (580°F) and cold (190°F) oil circulation and chemical transfer moving through a high purity chemical process. A comparison of energy consumption and reliability is made between a double gas seal and a conventional wet seal installed on a conventional pump and/or magnetic drive pump.

INTRODUCTION

Since its release, the Clean Air Act of 1990 has demanded more sophisticated and reliable methods of controlling VOC emissions from rotating equipment. Conventional single contacting liquid seals have proven to be very effective in controlling VOC emissions. However, the Clean Air Act calls out the use of dual mechanical seals on certain services. Typically, these seals are in tandem or double arrangements and require a lubrication system.

Tandem seal arrangements are used when the product cannot be released to the atmosphere and the buffer fluid cannot mix with the product. For a tandem seal arrangement, a nonpressurized buffer liquid is circulated in the outboard cavity for cooling. Double seals are used where the product cannot be released into the atmosphere, but the barrier fluid, between the seals, can mix with the product. A double seal requires a barrier fluid to be circulated at a higher pressure than the process fluid. This higher pressure barrier fluid will contaminate the product and must be safe to be released to the atmosphere. When replacing a single liquid seal with a conventional double liquid seal, horsepower consumption is higher, and increased monitoring of the barrier fluid level is required.

Dry running, noncontacting gas lubricated seals have now been developed for pump applications. Such designs eliminate the contact friction at the faces. Seals of this design have been applied where pressure ranges from vacuum to 300 psig, with shaft speeds to 5000 fpm. The gas lubricated noncontacting seal has been used in single, tandem, and double arrangements. The design and application of gas lubricated noncontacting seals for pump applications are discussed. A comparison to conventional sealing devices and magnetic drive or canned pumps is presented.

These seals provide less complex sealing systems that meet the requirements of the Environmental Protection Agency's (EPA) Clean Air Act of 1990.

ABSTRACT

Gas lubricated double seals are becoming more common in industry for pump applications where product emission, product contamination, and operating costs are a concern. Technology proven on large gas compressors is now being applied to pumps. The design features and implementation of double dry-running, noncontacting gas seals in a liquid application on end suction

DRY RUNNING NONCONTACTING GAS SEALS

Satisfactory life for any mechanical seal depends on the ability of the design and the materials of construction to minimize the effects of contact friction. Without the proper design and material considerations, a seal will destroy itself due to the thermomechanical effects of contact friction. For gas seals, the noncontacting design eliminates the contact friction allowing the seal to be used

where energy levels are too high to run dry running, contacting seals.

The gas seal faces ride on a gas film generated by spiral grooves, as shown in Figure 1. This spiral groove pattern is a series of logarithmic spirals recessed into the ring that is the harder material. The sealing dam is the area from the inner diameter of the spiral groove to the inside diameter of the face of the opposing ring.

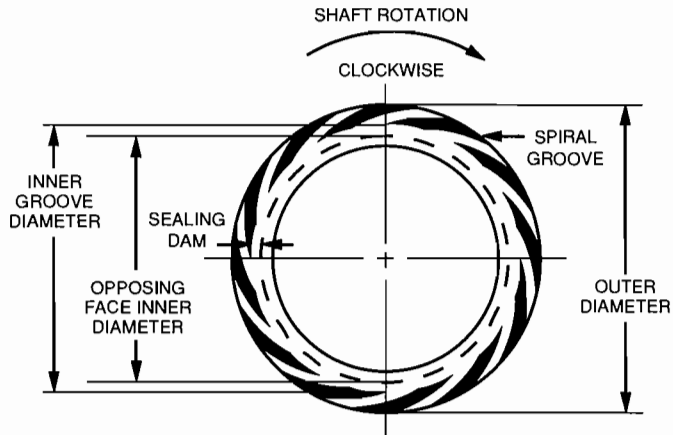

Figure 1. Typically Stationary Spiral Groove Sealing Surface.

Spiral groove seals operate using the principles of fluid mechanics. As the seal rotates, gas flows into the spiral groove by a viscous shearing action and is compressed. At the sealing dam, gas is expanded. The combined film pressure results in an opening force greater than the closing force that separates the faces a few hundred microinches. During pump shutdown, hydrostatic forces along with the spring load act to close the faces. Seal balance and the design of the spiral grooves prevent damage to the faces at startup and shutdown, before separation, when the faces contact.

The location of the spiral grooves on the mating ring is determined by the location of the pressure. A seal designed to handle pressure at the outer diameter (OD) of the primary ring normally has the spiral grooves on the OD of the mating ring. The pattern shown in Figure 1 is for a clockwise shaft rotation and OD pressure of a stationary mating ring [1].

CSTEDY[®] (John Crane Inc.) is a computer program that predicts gas seal load support and leakage. This program was used to optimize the face design. It considers the combined effects of pressure, temperature, materials of construction, fluid sealed, spiral groove information, and distortion of the faces. The program predicts the face profile and film thickness. It also predicts the stress and distortion due to temperature and/or pressure. Many different designs were run before the prototypes were made and tested. The program has proven to be a very valuable tool in optimizing designs and reducing the cost and time of prototypes. The predicted face separation of a double, gas lubricated seal (scale = 300:1) is illustrated in Figure 2. The fluid pressure created by the spiral grooves of a typical gas seal is shown in Figure 3.

TYPICAL APPLICATIONS OF DRY RUNNING NONCONTACTING GAS SEALS

Some early dry running, noncontacting gas lubricated seals were applied to blowers and fans, typically, in single and double arrangements, depending on the application. A single seal installed on a 4.437 in diameter fan is illustrated in Figure 4. Here, the release of the product to the atmosphere is not a concern.

Single seals can be mounted inside or outside the seal chamber, depending on space limitations. The single seal illustrated in

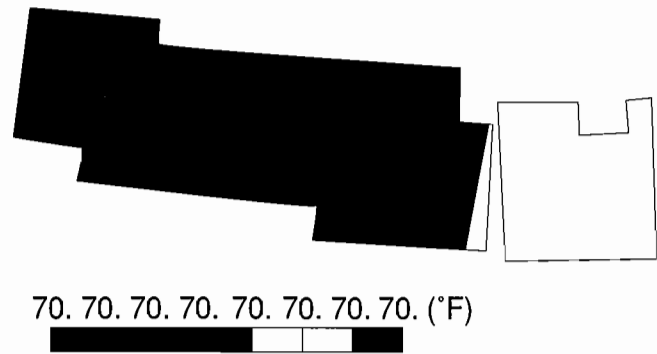

Figure 2. Face Separation of a Typical Noncontacting Gas Seal.

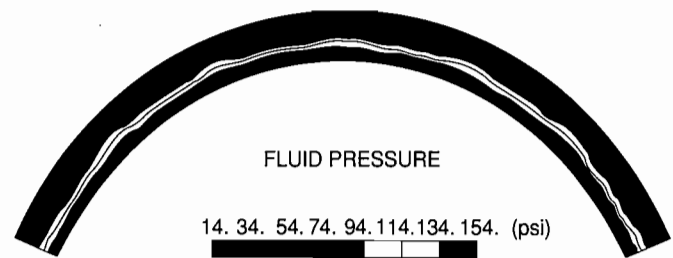

Figure 3. Fluid Pressure Generated by Typical Spiral Grooves for Gas Seals.

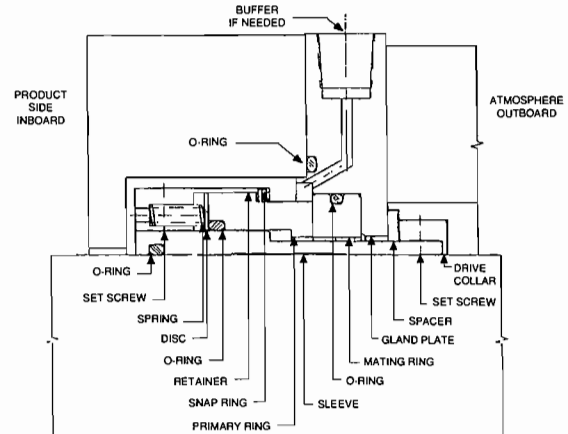

Figure 4. Single Gas Seal Installed on a 4.437 in Fan Shaft.

Figure 5 is mounted outside the seal chamber of a repeller pump on a chemical service. The seal has been running successfully for over eight years, sealing 99.5 percent nitric acid at 150°F and 1850 rpm. Dynamically, the seal is OD pressurized by the atmospheric pressure, due to the repeller creating a vacuum in the seal chamber. As the shaft rotates, the repeller generates a vacuum by centrifugal force, thus, removing all liquid from the seal chamber. During pump shutdown, the seal chamber is flooded with 20 psig process fluid pressure [2].

While single gas lubricated seals have proven to be effective in controlling VOC emissions, in some cases dual mechanical seals are sometimes required for complete control.

A double seal arrangement protects the environment from the process being sealed. Double seal arrangements use a pressurized barrier fluid between the seals at a higher pressure than the maximum process fluid pressure. The barrier fluid for a dry

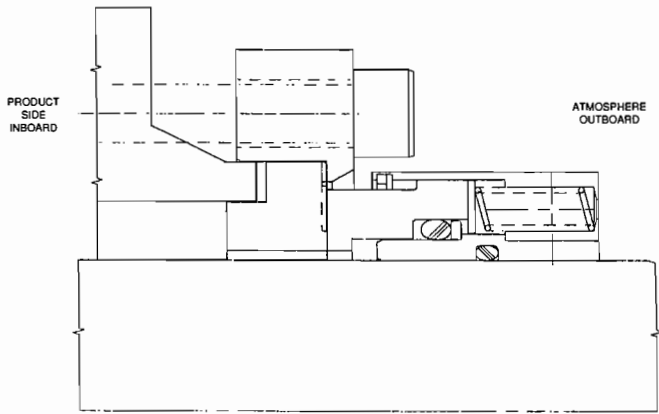

Figure 5. Outside Mounted Gas Seal for a Repeller Pump.

running, noncontacting gas seal is normally nitrogen or purified air at 20 psig above the maximum process pressure. Nitrogen is an EPA approved barrier fluid and meets the requirements of the Clean Air Act.

The second generation of dry running, noncontacting sealing for pump applications is illustrated in Figure 6. The double seal arrangement uses nitrogen at 35 psig above the process pressure. Gas lubricated double seals similar to the one shown in Figure 6 have been running successfully for over nine months at G.E. Plastics. Gas lubricated double seals were developed for this process because the barrier fluid for a liquid double seal would likely be regulated by the EPA as a Volatile Hazardous Air Pollutant (VHAP). Also, 99.9 percent product purity was required. Nitrogen was the only recommended barrier fluid. Emissions on the pumps have been monitored since startup over nine months ago. To date there has been no measured product emission leakage to the atmosphere, and the minimum product purity has been exceeded. G.E. considered magnetic drive pumps, but could not find a magnetic drive pump that could produce the output flow numbers required. Of the pumps fitted with gas lubricated double seals, there are two different seal sizes: 3.875 in diameter and 5.25 in diameter. The seals are installed on product pumps and on heat transfer pumps. The seals installed on product pumps are running at 2000 rpm, 40 psig pressure, at a product temperature above 320°F. The nitrogen barrier is set at 90 psig. An accumulator is incorporated into the nitrogen system to provide back up pressure for 30 min, if the nitrogen barrier is lost. An alarm is incorporated into the system to warn of the loss of nitrogen pressure. The nitrogen is passed through a 10-micron filter incorporating a coalescing element.

The pumps are steam jacketed because the product may solidify with a decrease in temperature. Within the last nine months the

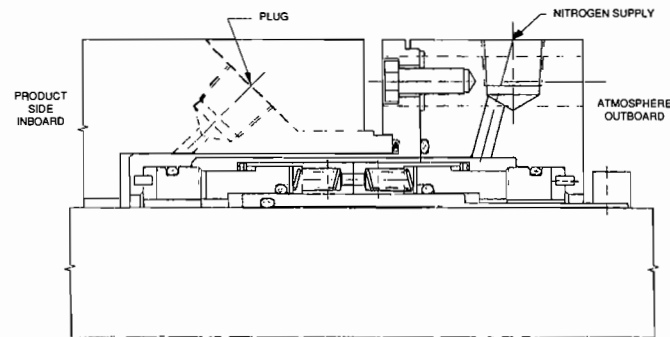

Figure 6. 3.875 in Diameter Gas Seal Installed on a Heat Transfer Pump.

product has solidified at the inside diameter (ID) of the inboard seal (process side) and caused the seal faces to remain open during pump shutdown. This condition was indicated by the drop in nitrogen barrier pressure and the increase in nitrogen flow measured by the flow meter between the filter and the seal chamber. If a liquid was the barrier fluid, the product would have been contaminated by a large amount of liquid until the barrier liquid ran out and the seals would be run dry. In the past, when using double liquid seals, this situation would dictate the shutdown and removal of the pumps and the replacement or rework of the seals. With the double gas seals, this is handled by replacing the nitrogen line with the steam line. The steam pressure applied to the seal is monitored to obtain sufficient pressure (temperature) to where the product would melt and the shaft could be rotated by hand. At this point, the flowmeter has returned to zero and the steam line is removed. The nitrogen line is replaced and the pump is restarted. This process takes a fraction of the time and cost associated with removing the pump and replacing or reworking the seals. Most important, zero product emissions were released to the atmosphere.

Gas lubricated double seals are also being used on heat transfer pumps with similar operating conditions as stated above but with the product temperature as high as 570°F. O-ring squeeze had to be reduced due to O-ring swell at this temperature. Within the first few days of operation, nitrogen consumption suddenly increased and nitrogen pressure decreased. This is a sign that the inboard seal faces remained open. The pump was removed from service and the seals were disassembled. Metal fines and welding flash were found under the inboard primary ring. The seal faces were replaced, and the seal and pump were reassembled and returned into service. The seals have been running successfully for over nine months. No product emissions were released to the atmosphere.

The double gas seals above have reduced mean time between planned maintenance (MTBPM) and have saved money in operating costs. The annual savings from running the double gas seals have been estimated to be as high as \$68,000 depending on the cost per kW.

COST SAVINGS FOR DRY RUNNING, NONCONTACTING GAS SEALS

The third generation of dry running, noncontacting sealing for pump applications is illustrated in Figure 7. Here, the seal is a double cartridge seal that uses nitrogen as the barrier fluid. This seal has been running successfully for over 16 months at a major chemical plant. Conventional liquid seals were being replaced every month. The seal is installed on a chemical pump utilizing a repeller design, but a conventional centrifugal pump can be used. This seal design has passed thousands of hours of testing on a conventional centrifugal pump. There is a patent pending on this design. The operating conditions are 1800 rpm to 3600 rpm,

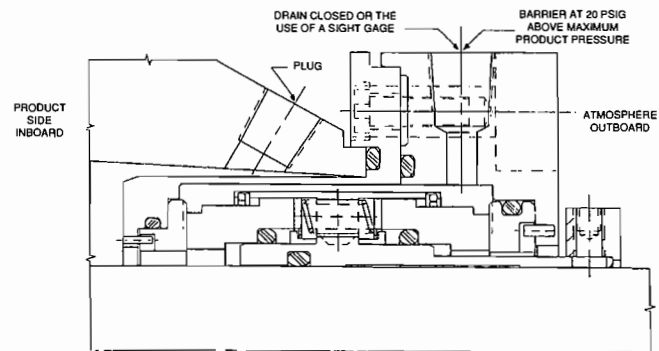

Figure 7. 2.625 in Diameter Gas Seal Installed on a Pump.

product temperature up to 300°F, barrier pressure at 30 psig, dynamic seal chamber pressure is vacuum, while shutdown pressure is suction pressure that is around 15 psig [3].

The seal illustrated in Figure 7 has been running successfully in a phenol service also on repeller pumps with similar operating conditions as stated above. The customer chose repeller pumps due to the low nitrogen pressure available at the plant. There are 22 pumps using dry running, noncontacting gas seals at this major chemical plant.

The customer considered using magnetic drive pumps, but decided to go with double gas seals and repeller pumps, due to the operating costs of magnetic drive pumps. Magnetic drive pumps consume approximately three times the horsepower than a conventional centrifugal pump utilizing double liquid seals. A horsepower consumption, by the seal, comparison between a liquid seal and a gas seal is discussed later. Efficiency of magnetic drive pumps is reduced when a bypass from discharge is incorporated to supply lubrication and cooling to the shaft bearings. Heat generated by the bearings will increase the bypass fluid, thus increasing the chance of flashing the product. An increase in process fluid temperature can result by using a bypass from discharge. In this application, the product cannot be used as the bearing lubricant, an outside source would have to be incorporated to provide the cooling and lubrication to the bearings. This would increase the operating cost because of the additional system equipment. The customer was also very concerned about the possibility of the shaft bearing running dry. This situation would cause catastrophic failure within seconds. Field repair usually involves sending the pumps back to the manufacturer for repair.

The seal illustrated in Figure 7, like the seal illustrated in Figure 6, is designed to run dry. During pump shutdown, if the nitrogen pressure is lost, the inboard seal will remain closed due to the design of the inboard mating ring. The mating ring will remain in place and the O-ring is confined so that no product will get into the barrier chamber. The seal has passed several ID static pressure tests up to 300 psig. No leakage occurred into the barrier chamber. A tap at the bottom of the seal cartridge allows the operator to use a sight gage to check for any liquid in the barrier chamber. Liquid in the chamber can be the result of an inboard seal failure or moisture in the gas barrier system. This seal arrangement provides 0.0 product emissions into the atmosphere and emission monitoring is not required. The recommended barrier support system for a double dry running, noncontacting gas seal is illustrated in Figure 8.

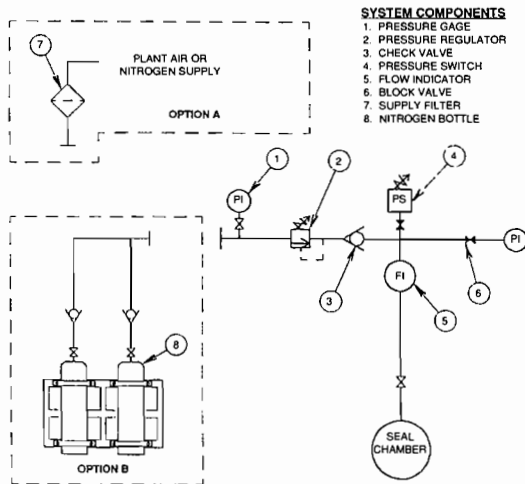

Figure 8. Barrier System for a Double Dry Running, Noncontacting Gas Seal.

Nitrogen consumption for double gas seals is relatively low. The standard leakage chart for a single gas seal is depicted in Figure 9. Nitrogen leakage is directly related to the size of the seal, speed of the pump, and the pressure differential across the sealing faces. For the operating conditions of the seal illustrated in Figure 7, leakage will be around 300 ml/min. Most of the 300 ml/min leakage is to the atmosphere due to the greater differential pressure. Assuming 24-hour continuous service and an average cost of nitrogen of \$.30/1000 ft³, the yearly costs estimate of nitrogen would be \$1.67. The cost for a typical double liquid seal requiring 0.5 gpm of flush, assuming 24-hour continuous service and the utility water cost at \$0.5/ft³ would be \$1,756 a year.

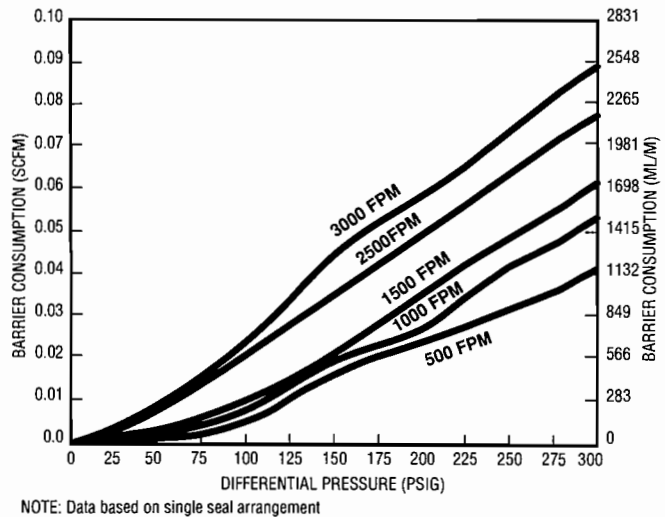

Figure 9. Standard Leakage Chart for Single Gas Seals.

The biggest advantage to using a double gas seal is the saving in energy. Power consumption can be reduced by a factor of 20 to 50, depending on the operating conditions and the size of the seal. This reduction in power results in reduced operating costs. The calculated horsepower consumption comparison is shown in Figure 10, between a double gas seal and double liquid seal, and the energy comparison between the seals is shown in Figure 11.

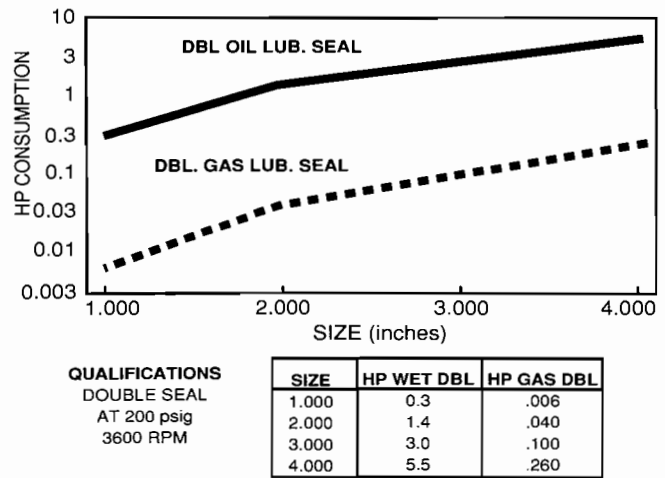
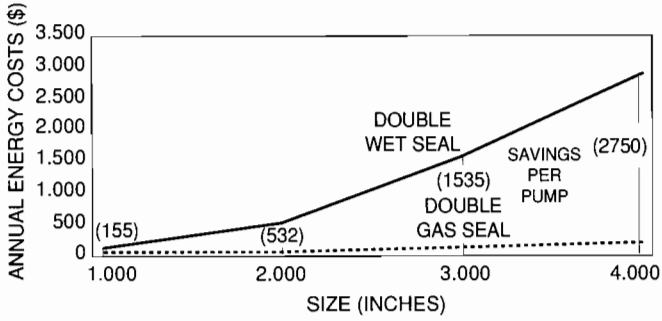

Figure 10. Horsepower Consumption Comparison Between a Double Liquid Seal and a Gas Seal.



Double Wet Seal Operating Cost
 Typical 2.000" D. seal consumes 1.40 HP
 Where: HP x .745 = KW
 (1.40 HP) x (.745) = 1.043 KW
 Based on \$.06/KWH Energy Cost
 (1.043 KW) x (\$.06/KWH) (24) (365) = \$548/year

SIZE	COST/YR WET	COST/YR GAS	SAVINGS/YR W/GAS
1.000	\$158.00	\$2.35	\$155.65
2.000	548.00	15.70	532.30
3.000	1,575.00	39.15	1,535.85
4.000	2,890.00	136.60	2,753.40

Figure 11. Energy Costs Comparison Between a Double Liquid Seal and a Double Gas Seal.

The use of double gas seals can also increase the MTBPM. A major chemical plant has documented a 2000 percent increase in MTBPM. Monitoring time is also saved when using double gas seals. As stated earlier, a double gas seal using pressurized nitrogen as the barrier fluid does not require monitoring. The number of monitoring personnel can be reduced if double gas seals are used on certain VOC services [4].

CONCLUSION

Currently, there are over 70 dry running, noncontacting gas lubricated double seals in service. They are becoming more common in industry due to successful applications such as the ones described herein. Double gas seals offer many advantages over conventional liquid seals such as increased seal life, increased MTBPM, decrease in seal horsepower consumption, and the elimination of liquid support systems and product contamination. They offer many cost savings advantages when compared to magnetic drive or canned pumps. Dry running, noncontacting gas seals simplifies low emission sealing, while providing zero product release to the atmosphere.

REFERENCES

1. Netzel, J. P., "High Performance Gas Compressor Seals," 11th International Conference on Fluid Sealing, BHRA, Cranfield, Bedford, UK (1987).
2. Netzel, J. P., "Sealing Technology, A Control For Industrial Pollution," Lubrication Engineering, pp. 483-493 (1990).
3. Wasser, J. R., "Dry Seal Technology for Rotating Equipment," 48th Annual Meeting of STLE (1993).
4. Lockheed, T. A., "Can We Do It?," Chemical Processing (January 1992).