



Canned Motor Pump Failure

A Case History of Canned Motor Pump Failures – Demystifying the Thrust force

Vineet Jindal

Rotating Equipment Engineer – Shell Chemicals Seraya Pte Ltd , Singapore

Problem Statement

- The subject pump is a Overhung Canned Motor Pump pumping Condensate with traces of Ethylene Oxide.
- The pump has a thrust balancing mechanism comprising of a rotating thrust disk and a stationary carbon ring.
- The pump has a secondary impeller which takes suction from main discharge line and circulates the cooling fluid to cool the motor windings.
- The pump is installed with a axial position measuring device called 'ARM 2000' which provides the real time position of the rotor.
- The axial position signal is monitored in DCS with an alarm and trip interlock.
- In addition to axial position , winding temperature of the motor and power output also has signals coming to DCS , though without alarms.

Problem Statement – The Pump Cross Sectional Drawing

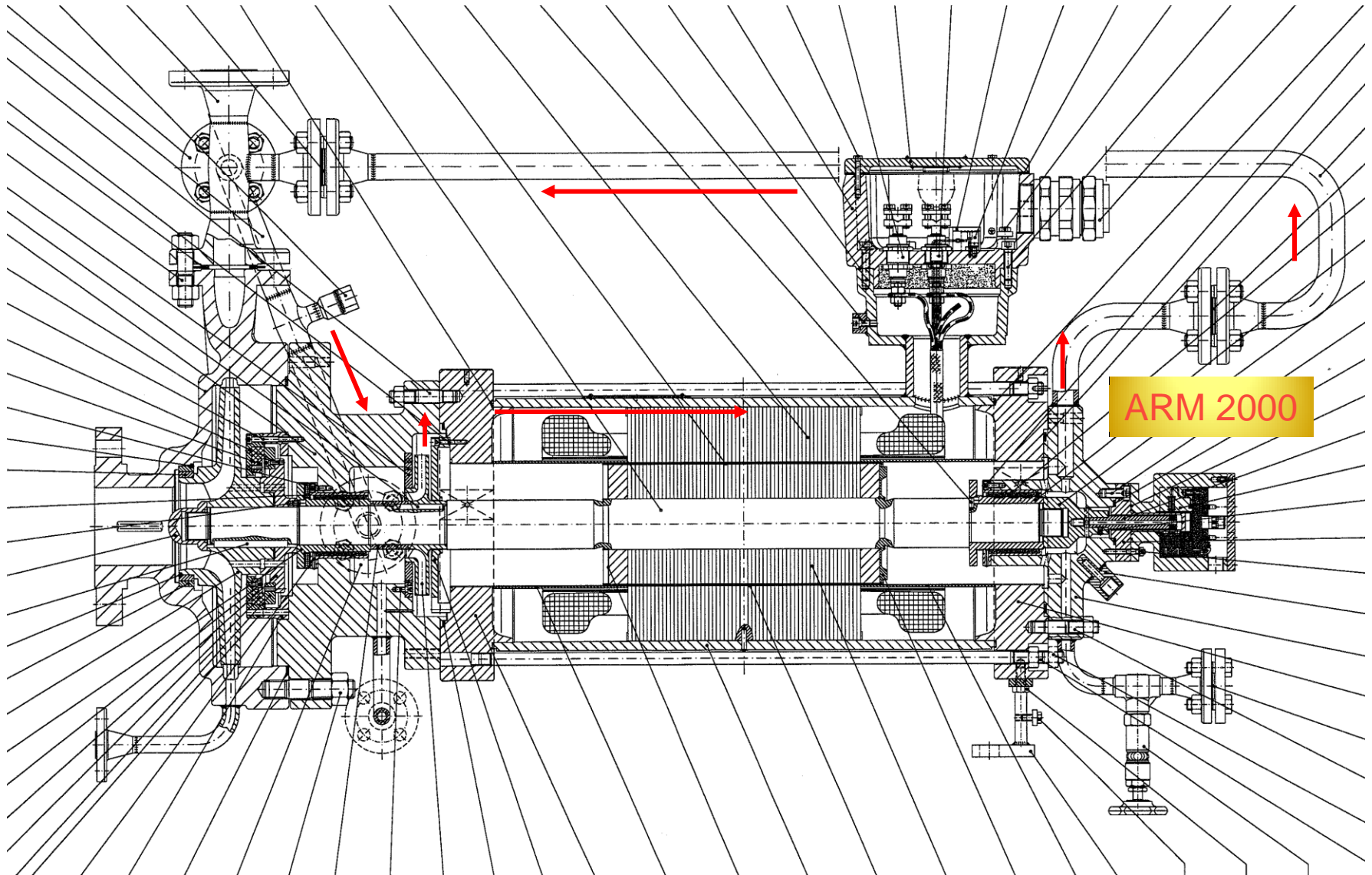

Problem Statement

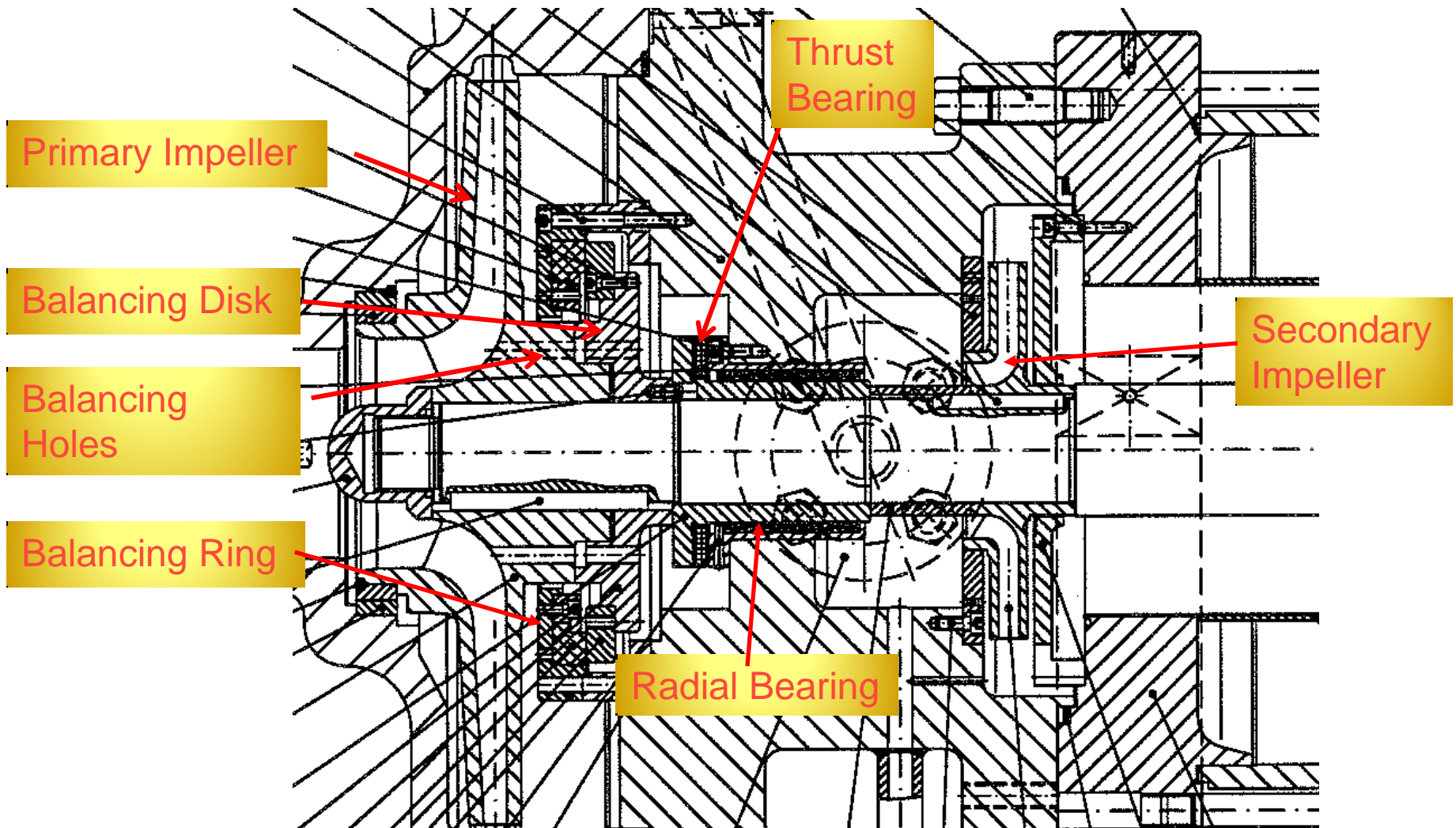

Problem Statement – Failure Mode

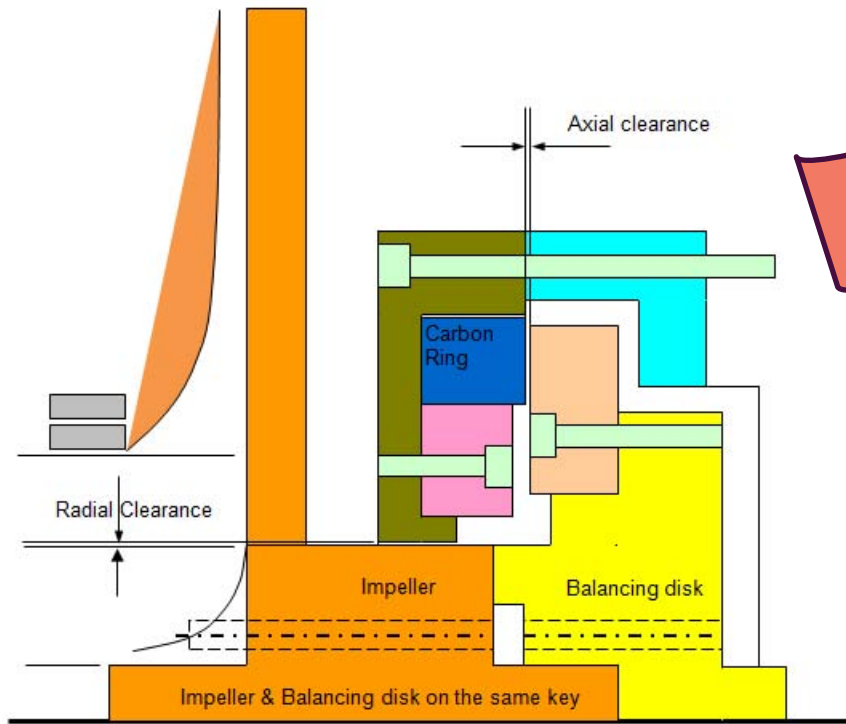

- In a typical failure mode, axial position will change and motor current will increase.
- The carbon ring would be found heavily rubbed & damaged

Problem Statement – How we saw it

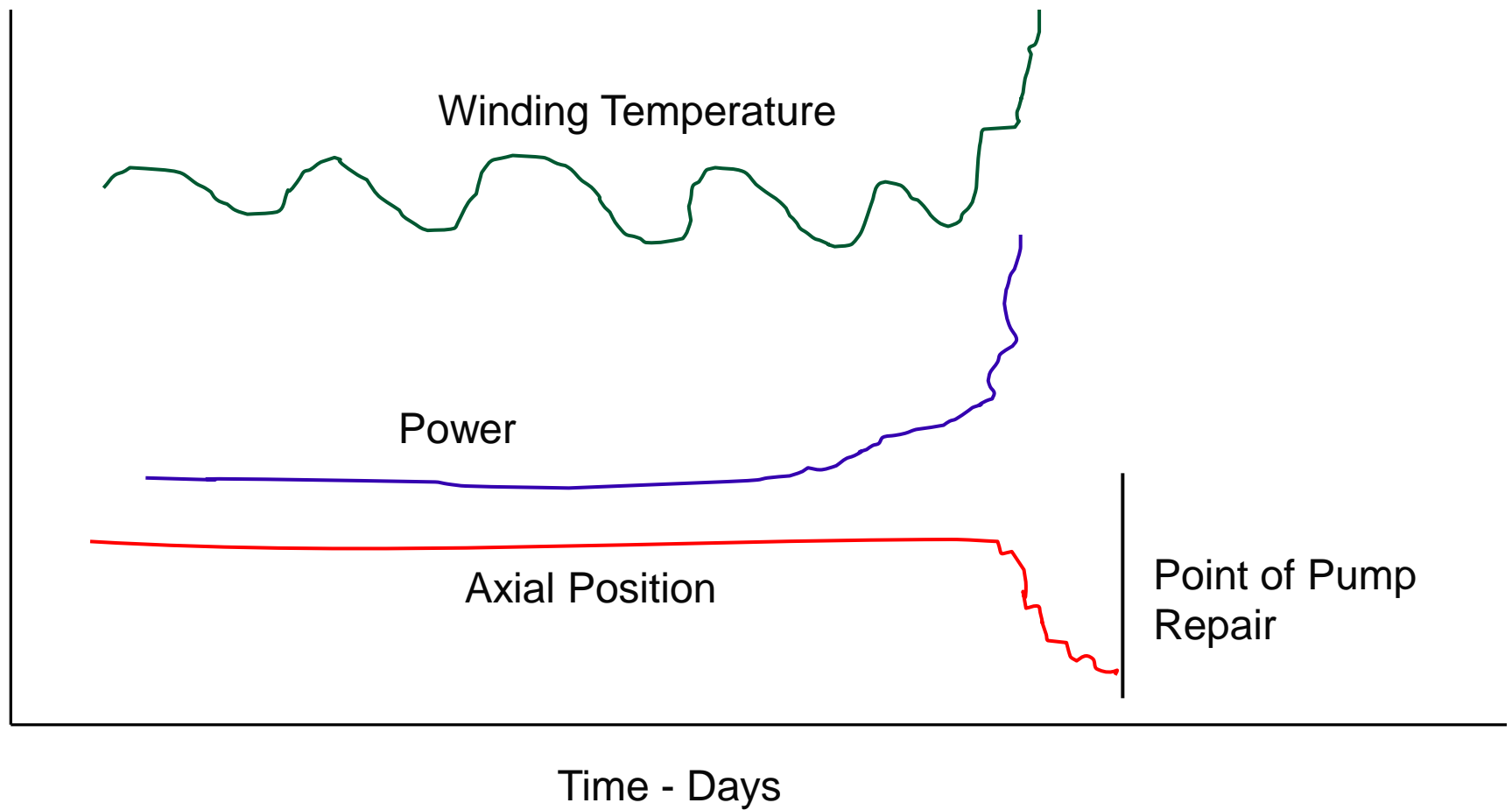

Problem Statement – Time Line

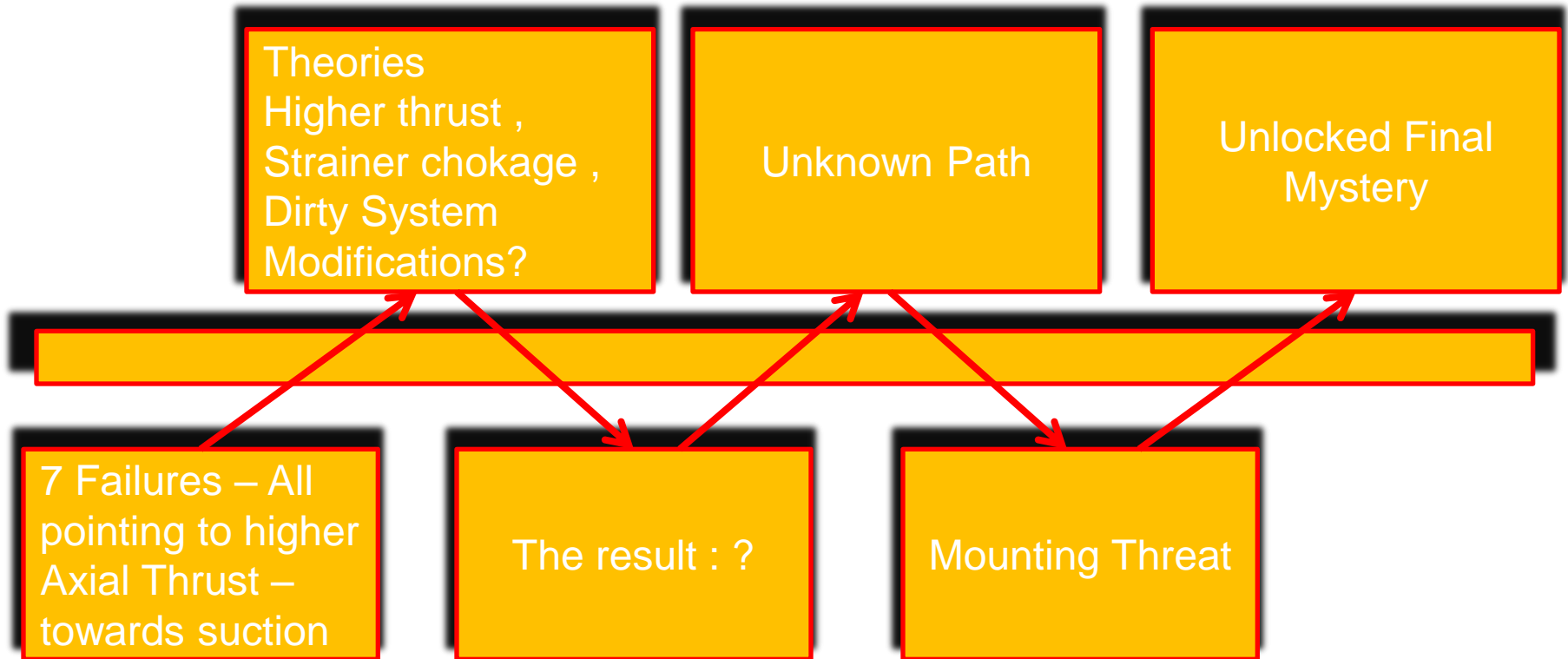

Analysis – First Modification

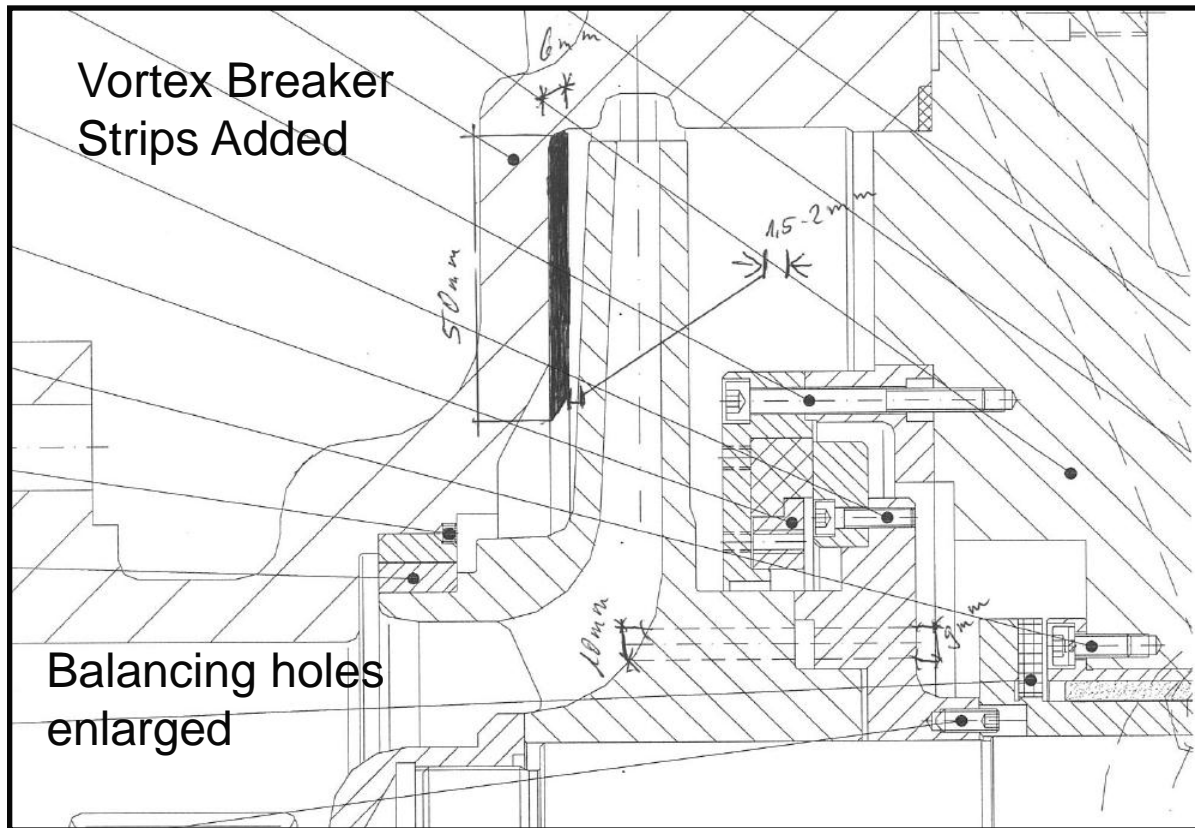

Vortex Breaker Strips created pressure on the suction end of the pump to counter thrust towards suction.
Balancing holes enlarged to facilitate balancing action.

Problem Statement – Time Line

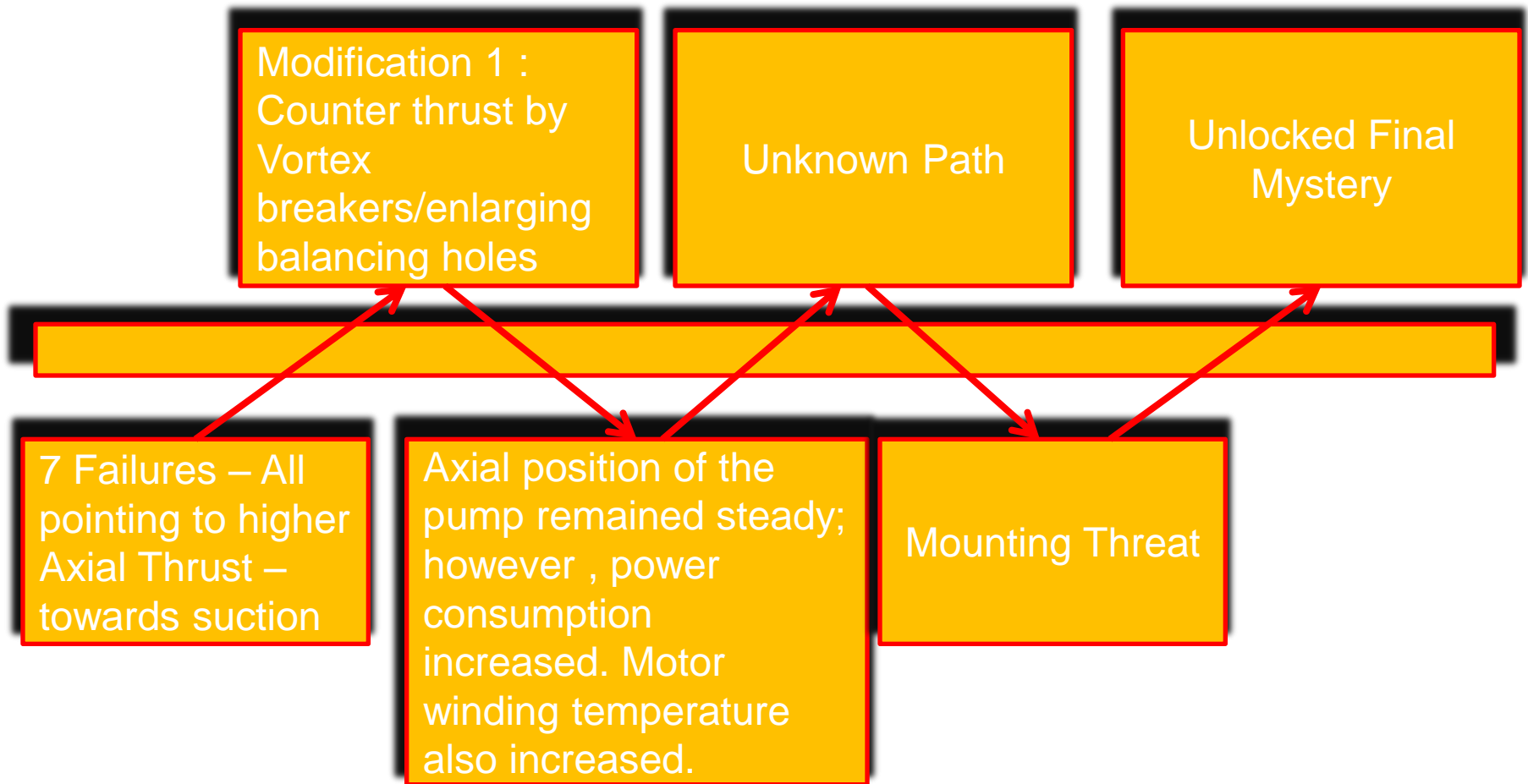

Problem Statement – Effect of First Modification

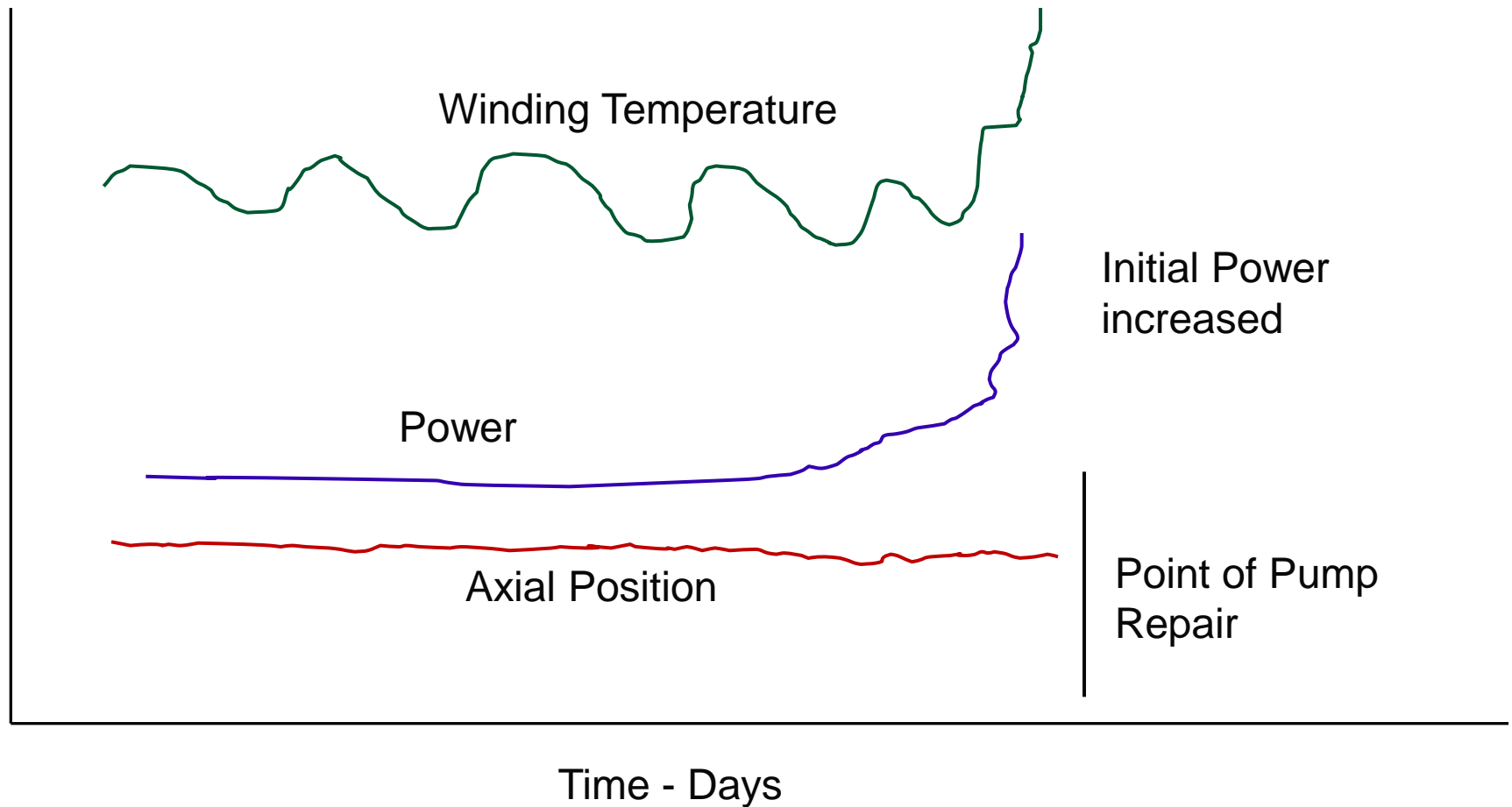

Problem Statement – Time Line

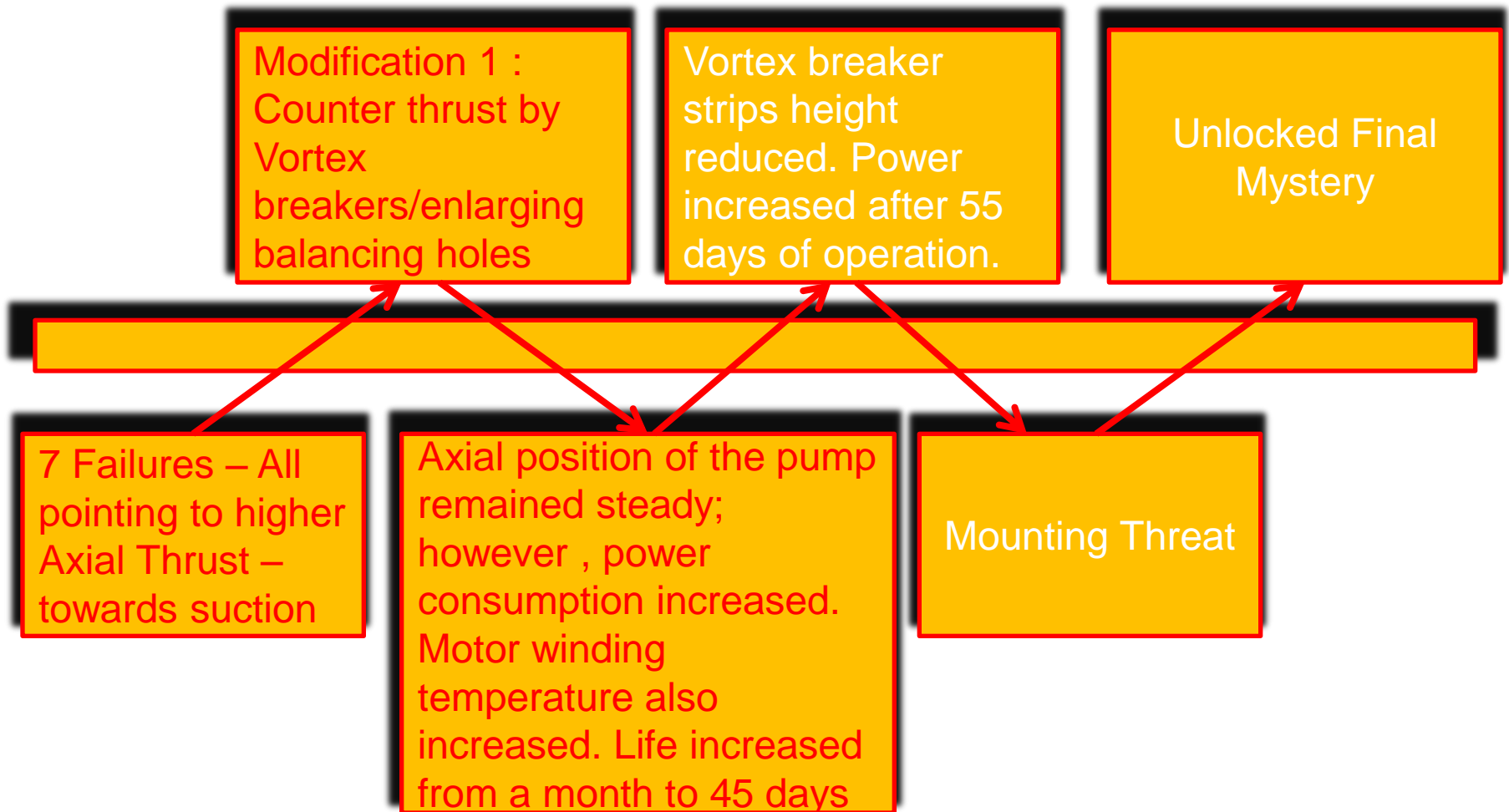

Problem Statement – Time Line

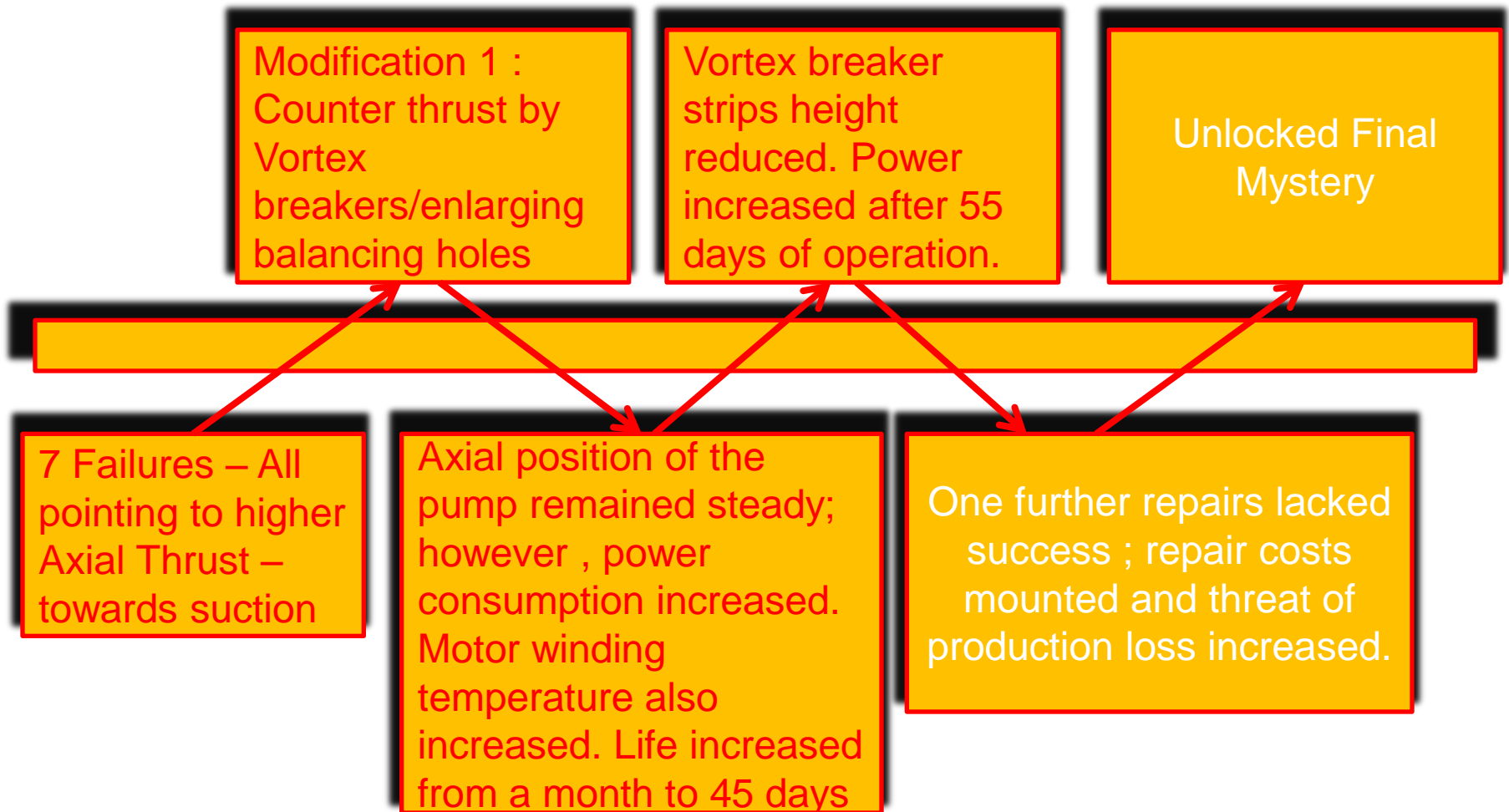

Problem Statement – The Pump Bill of Material

Parts list

Equipment-no.:		4110007412/031-01-02		Item-no.: P-8402 A/B			Sectional drawing no.: 73818		
Customer:		Shell Eastern Petroleum (Pte.) Ltd.				GA drawing no.: Mz. 19610.1A / 1B			
Pump + Motor type:		CNPf 100x40x350 B + N 80rm-2				08.05.08 sh			
Part no.	Ident no.	Description / original	Description / translation	Dimension	Material	comparable ASTM	Drawing	Quantity	
102.00	227382401	Spiralgehäuse	volute casing	CNP 100X40X350B; 1,5X4X14B	1.4409	A351 Gr.CF3M	73824 IX	1	
146.00	227382501	Zwischenlaterne	intermediate lantern	N 74/80/85	1.4571	316 L	73825 IX	1	
230.01	226609304	Laufrad	impeller	CNP/CNPk 100X40X350-B;1,5X4X14-B	1.4409	A351 Gr.CF3M	66093.1 IX	1	
230.03	225683903	Laufrad	impeller	CAM 41	1.4468	A890 Grade 3A	56839 IXE	1	
360.00	227379602	Lagerdeckel	bearing cover	CKP/N 74/80	1.4571	316 L	73796 IX	1	
400.02	264009204	Kammprofildichtung	grooved gasket	Ø 92,1 Ø 69,8 Ø 52,4 X 5	1.4571/Graphit	316L / Graphite	- IE	1	
400.03	264110185	Flachdichtung	gasket	Ø 318 Ø 302 X 0,6	CRNI-Graphit	316 / Graphit	- IE	1	
400.04	264110185	Flachdichtung	gasket	Ø 318 Ø 302 X 0,6	CRNI-Graphit	316 / Graphit	- IE	1	
400.05	264001959	Spiraldichtung	spiral wound	SPVNG FÜR NUT Ø 261 Ø 245 X 3,3	1.4404/Graphit	316 L / Graphite	- IE	1	
400.07	264001946	Spiraldichtung	spiral wound	SPVNG FÜR NUT Ø 232 Ø 210 X 3,3	1.4404/Graphit	316 L / Graphite	- IE	1	
400.09	264000228	Flachdichtung	gasket	Ø 238 Ø 210 X 2	Gummi	Rubber	05324 IR	1	
400.15	264000538	Flachdichtung	gasket	Ø 208 Ø 164 X 0,5	AFM 34	-	14357.1 IE	1	
400.30	264001947	Spiraldichtung	spiral wound	SPVNG FÜR NUT Ø 57 Ø 41 X 3,3	1.4404/Graphit	316 L / Graphite	- IE	1	
400.50	264006905	Kammprofildichtung	grooved gasket	Ø 69,8 Ø 47,6 Ø 36,5 X 5	1.4571/Graphit	316L / Graphite	- IE	4	
400.94	264005001	Kammprofildichtung	grooved gasket	Ø 50,8 Ø 33,3 Ø 23 X 5	1.4571/Graphit	316L / Graphite	- IE	1	
411.10	264001960	Spiraldichtung	spiral wound	SPVNG FÜR NUT Ø 383 Ø 360 X 3,3	1.4404/Graphit	316 L / Graphite	- IE	1	
411.15	264110140	Dichtring	gasket	Ø 13 Ø 8,2 X 2	Nickel	Nickel		1	
412.06	264121175	Runddichtring	o-ring	Ø 40 X 2,5	FPM	FKM		1	
472.01	264720104	Gleitring	slide ring	Ø 110 Ø 70 X 6	PTFE/K=25% 2.2	PTFE	L IR	1	
472.03	227384901	Entlastungsring	balancing ring	Ø 203 Ø 153,5 X 16	FH 42A		73849 IX	1	
502.01	227385201	Spaltring	wear ring	Ø 155 Ø 140,5 X 20	JL 1040 GJL-250(GG-25)	A 126 - Class B	73852 IX	1	
502.02	226075703	Spaltring	wear ring	Ø 185 Ø 95 X 10	JL 1040 GJL-250(GG-25)	A 126 - Class B	60757.3 IX	1	
503.01	227385301	Lauftring	friction ring	Ø 140 Ø 125 X 20	JL 1040 GJL-250(GG-25)	A 126 - Class B	73853 IX	1	
506.00	227385001	Haltering	lifting ring	Ø 172,5 Ø 123 X 13	1.4571	316 L	73850 IX	1	
512.01	227384801	Entlastungsgegenring	balancing counter ring	Ø 237 Ø 113 X 23	1.4571	316 L	73848 IX	1	
512.02	227385101	Entlastungsring	balancing ring	Ø 201 Ø 147 X 14	1.4462/kolsterisiert	A276 -S31803 / colsterized	73851 IX	1	
512.03	226898503	Zwischenscheibe	intermediate disc	N 74/80/85 (Ø225/ Ø63)	JL 1040 GJL-250(GG-25)	A 126 - Class B	68985 IX	1	
520.01	225200126	Verstärkungshülse	reinforcing sleeve	Ø 158,4I X 2,5 X 175	1.4462/1.4470 2.2	A276 -S31803	- IXER	1	
520.02	225200126	Verstärkungshülse	reinforcing sleeve	Ø 158,4I X 2,5 X 175	1.4462/1.4470 2.2	A276 -S31803	- IXER	1	
525.01	226216902	Abstandhülse	distance sleeve	Ø 62 Ø 50 X 48,5	1.4571	316 L	62169 IXE	1	
529.01	212357205	Lagerhülse	bearing sleeve	CKP 84-600	1.4571/W5	316L/Tungsten	23572.2 IXE B	1	
529.02	212357205	Lagerhülse	bearing sleeve	CKP 84-600	1.4571/W5	316L/Tungsten	23572.2 IXE B	1	
545.01	212348065	Lagerbuchse	bearing bush	CKP 84-610	1.4571/SIC-30	316L/Silicium Carbide	23480.5 IXR B	1	
545.02	212348065	Lagerbuchse	bearing bush	CKP 84-610	1.4571/SIC-30	316L/Silicium Carbide	23480.5 IXR B	1	
550.03	210115064	Deckscheibe	cap disc	Ø 154 Ø 64 X 0,5	1.4571	316 L	01150 IXE B	1	
550.04	225486201	Deckscheibe	sealing disc	Ø 154 Ø 64 X 10	1.4571	316 L	54862.1 IXE B	1	

Cast Iron

Analysis

In July 2010 , a close look at the cast iron parts revealed a clue to the Mystery



- The wear rings on primary impeller were found soft as carbon.
- The secondary impeller back and front shrouds were found soft as a chalk!

All cast iron components were replaced with SS 316 to prevent Galvanic Corrosion.

A relook at the pumping medium revealed the following :
 The pump contains more than 85% of water by volume.
 Water being an excellent electrolyte , caused the “Galvanic Corrosion”

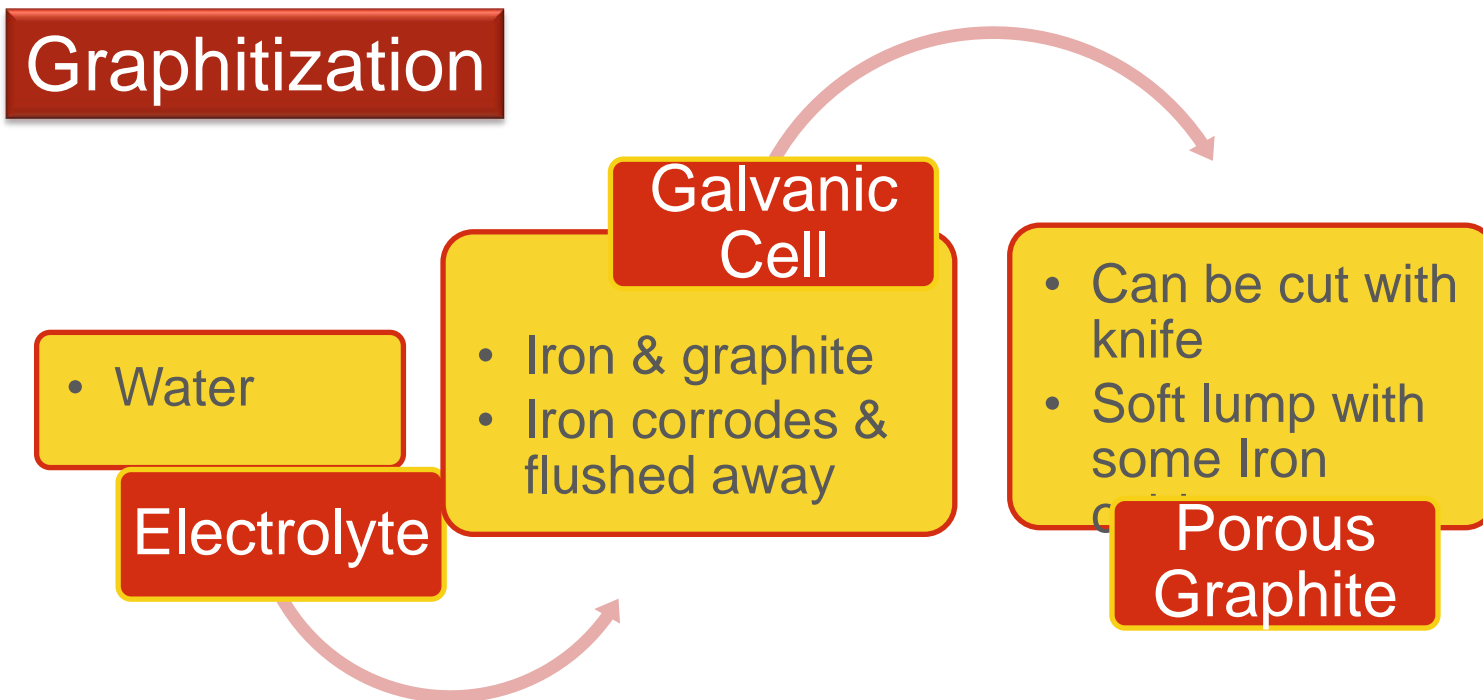

Conclusions - What Actually happened

Pumping liquid contained more than 85% water

Electrolytic Cell formed between SS and Cast iron(Wear rings);Galvanic corrosion initiated on pump operation.

Iron in the Cast iron wear ring corrodes away ; Wear rings clearance enlarged.

Pressure breakdown on the suction end of the impeller forcing the rotor towards suction.

The rotor thrust acts on the Carbon ring in the balancing assembly. Carbon ring damages .Power increased due to recirculation

Lessons Learnt – How we saw it

Axial Position of the Pump rotor indicated movement towards suction ; Power output increased.



Carbon ring found damaged with symptoms of severe rubbing.



High thrust resulted concluded as the root cause – root cause uncertain



Vortex breakers welded to counter higher thrust; Provided temporary additional life.



Root cause remained hidden for a while but finally surfaced.

185
Questions?

