

BENEFITS OF A BALANCED INTERFERENCE FIT BELLOWS SEAL DESIGN IN HIGH TEMPERATURE CORROSIVE APPLICATIONS

by

David P. Casucci

Engineering Manager, Industrial Division

and

William J. McCollough

Applications Engineer

EG & G Sealol

Cranston, Rhode Island



David P. Casucci is Engineering Manager in the Industrial Division of EG & G Sealol in Cranston, Rhode Island. Mr. Casucci has a B.S. degree in Mechanical Engineering and Applied Mechanics from the University of Rhode Island. His responsibilities include the application, design, and development of metal bellows seals for pumps and rotating equipment. Since joining EG & G Sealol in 1978 as Product Engineer, he has held positions in Engineering and Customer Service at different EG & G Sealol divisions. Mr. Casucci is a member of STLE and has been a co-author for several documents on mechanical metal bellows seals.

neering and Customer Service at different EG & G Sealol divisions. Mr. Casucci is a member of STLE and has been a co-author for several documents on mechanical metal bellows seals.



William J. McCollough is an Applications Engineer with the Industrial Division of EG & G Sealol in Cranston, Rhode Island. Mr. McCollough has a B.S. degree in Mechanical Engineering and Applied Mechanics from The University of Rhode Island. His responsibilities include recommending seals and their supporting systems, based on material compatibility and service conditions, for a variety of rotating equipment applications. He provides technical service and support for the petrochemical, chemical, and general industry market segments.

technical service and support for the petrochemical, chemical, and general industry market segments.

ABSTRACT

Metal bellows seals, originally developed for the aerospace/defense industry, are now widely accepted in the petrochemical, chemical, and general industrial markets. Metal bellows seals offer enhanced dynamic tracking of the seal rings because they eliminate dynamic secondary seals. They are ideally suited for difficult high temperature applications, like those in the petrochemical industry that demand enhanced seal reliability.

An effective means of ensuring seal reliability is by controlling face distortion, which directly affects the operating conditions at the sealing surface. When designing a seal, it is necessary to consider distortion resulting from pressure, the presence of temperature gradients in the area of the interface, and stress relaxation of interference fit components. All three of these factors can result

in distortion of the face and changes to the lubricating fluid film thickness between the faces.

Historically, to reduce stress relaxation of interference fit components in high temperature applications, material selection was limited to materials with a coefficient of thermal expansion similar to that of the seal ring insert. Recently, innovative design and manufacturing technology has made it possible to offer metal bellows seals made of corrosion resistant alloys for high temperature applications (up to 800°F).

This design controls face distortion at elevated temperatures. It does this through design rather than material selection, which limits the applicability of the seal. A comparison of the new design to more traditional designs is made and the performance advantages, including experimental and field test results, are described.

The combination of an optimized metal bellows and balanced interference fit technologies provide enhanced seal performance for high temperature, corrosive applications.

INTRODUCTION

In the last ten years, metal bellows seals have become an industry accepted method of sealing high temperature applications. Metal bellows seals have performed reliably at temperatures as high as 700°F without cooling [1, 2]. Many U.S. refineries specify that only metal bellows seals can be used for applications with temperatures above 350°F.

Current metal bellows seal technology uses an interference fit to join the nonmetallic wear face to the metal bellows shell. For most high temperature applications, shell materials with a low coefficient of thermal expansion (CTE) must be used to minimize the relaxation of interference fit stress between these dissimilar materials. The availability of metals with low CTE and good corrosion resistance is extremely limited.

Generally, mechanical seals can be affected by certain temperature and pressure sensitive criteria that upset the operating conditions at the seal interface. The development of a unique shell/insert design, called the decoupled, balanced interference fit [3], provides additional face stability and has proven to be a superior design in high temperature, corrosive services. It allows the use of high strength, corrosion resistant materials, with high CTE relative to the insert material, to be used in the shell/insert arrangement.

To understand the significance of the improved design, it is necessary to discuss the following critical mechanical seal design features:

- face loading and hydraulic balance,
- bellows plate (diaphragm) shape optimization and,
- applications of finite element analysis (FEA) to enhance seal face stability.

These topics will provide the background information necessary to understand a detailed discussion of the decoupled, balanced interference fit design. In house and field test results will be discussed along with other possible critical applications where the new design can provide improved performance.

FACE LOADING AND HYDRAULIC BALANCE

It is important to note that the forces acting on a bellows seal are significantly different from the forces acting on other types of mechanical seals. An example of this can be easily demonstrated with a comparative analysis between a pusher type seal and a bellows seal as follows:

Pusher Type Seal

A free body diagram of a basic balanced pusher type seal is illustrated in Figure 1. By using the free body diagram, an equation determining the mechanical contact pressure, P_{mc} (F_{mc}/A_o), can be derived and is shown as follows:

$$P_{mc} = P(B - K) + P_s \tag{1}$$

where,

K = Pressure gradient factor (dimensionless)

P_s = F_s/A_o (lbs/sq in)

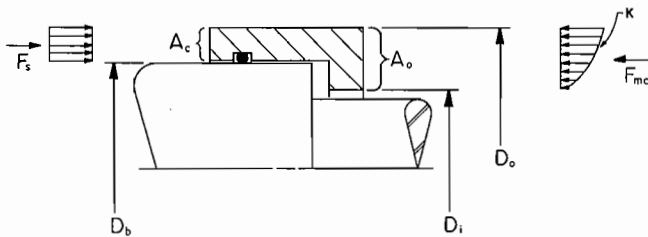

Figure 1. Free Body Diagram of Pusher Seal.

The dimensionless factor (K) defines the shape of the pressure gradient in the seal interface from the OD to the ID. There are many variables that determine K for a particular application. For parallel seal faces, a K value of 0.5 is typically used, representing a linear pressure drop.

The term balance (B) refers to the ratio of closing and opening areas affected by the fluid pressure (P , lb/sq in), from Figure 1:

$$B = \frac{A_c}{A_o} = \frac{D_o^2 - D_b^2}{D_o^2 - D_i^2} \tag{2}$$

Special care must be taken when selecting the appropriate balance ratio. Selecting a low balance ratio can be detrimental if ID contact occurs at the seal faces and K approaches 1.0. If K becomes significantly greater than B , the opening forces overcome the spring force and the seal faces separate. High balance ratios can result in excessive face loads at higher fluid pressure, especially if OD contact causes K to approach 0. For these reasons, it is common practice to select a balance ratio between 0.65 and 0.75.

It is evident from Equation (1) that P_{mc} is a linear function of pressure, for a particular design, with a constant B and K . Therefore, with a proper balance ratio, P_{mc} can be optimized to reduce friction and wear at the seal faces.

Bellows Seal

A free body diagram of a bellows seal is shown in Figure 2 with attendant fluid pressure and mechanical forces. An equation for

the mechanical contact pressure, P_{mc} (lb/sq in), can be derived from Figure 2 and is as follows:

$$P_{mc} = \frac{F_r}{A_2} - P \left(\frac{A_3}{A_2} + K \right) \tag{3}$$

where,

F_r = Bellows axial reaction force (lb)

P_{mc} = F_{mc} / A_2 (lb/sq in)

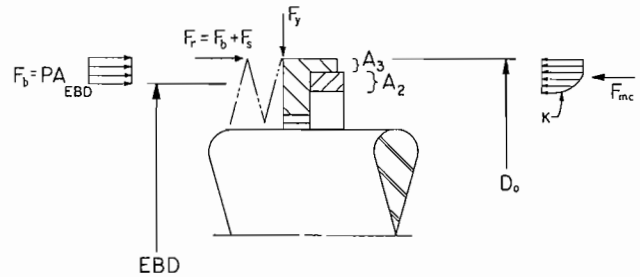

Figure 2. Free Body Diagram of Welded Metal Bellows Seal.

The bellows axial reaction force (F_r) consists of two components; one resulting from bellows spring force at operating length, F_s (lb), and another from hydraulic pressure, F_b (lb). F_r is not constant with respect to pressure due to changes in the geometry of the bellows plates as fluid pressure varies. Values of F_r are determined experimentally as a function of pressure. A typical curve of F_r versus fluid pressure is shown in Figure 3. By using experimentally determined values of F_r as a function of pressure and choosing appropriate dimensions of A_2 and A_3 , the face contact pressure can be optimized to decrease wear and increase seal life.

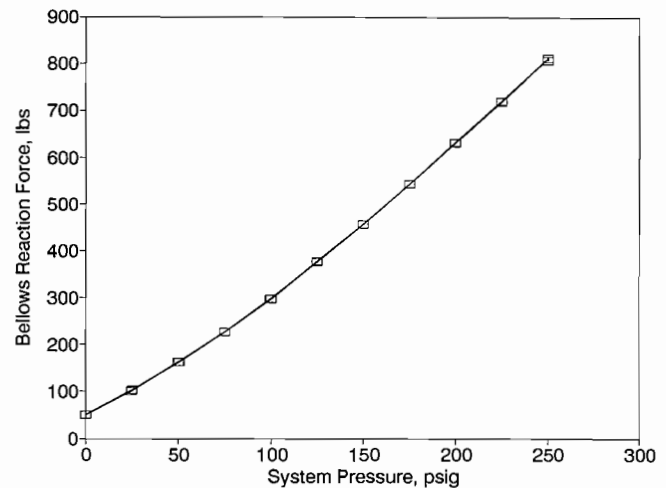

Figure 3. Bellows Reaction Force vs System Pressure.

The variation of P_{mc} with system pressure and K for both pusher and bellows seals is demonstrated in Figure 4. Values of P_{mc} were determined using Equations (1) and (3), respectively, for three different values of K (0.5, 0.75, and 1.0). For the pusher type seal, with $B = 0.675$, $F_s = 50$ lb, and $A_o = 2.68$ sq in, P_{mc} varies linearly with constant B and F_s , as shown in Figure 4. For bellows seals using similar design parameters (i.e., balance at 0 psig = 0.675, F_s

= 50 lb, and $A_2 = 2.68$ sq in), plotted values of P_{mc} are nonlinear with respect to pressure [4].

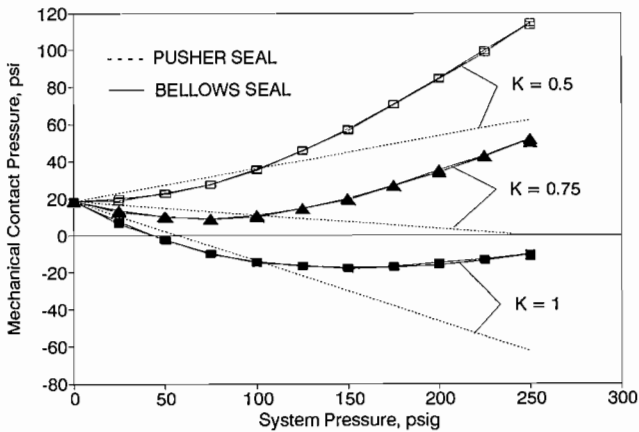

Figure 4. Mechanical Contact Pressure vs System Pressure.

BELLOWS PLATE SHAPE AND CONFIGURATION

Two typical bellows plate shapes are shown in Figure 5; one with the ID flat portion of the bellows plates perpendicular to the bellows axis, and another with the bellows ID flats tilted at an angle in relation to the bellows axis. For externally pressurized seals with the flat portion of the plate perpendicular to the bellows axis, the area near the ID weld is found to be the most highly stressed. Hulbert, et al., determined that tilting the bellows plate with respect to the bellows axis reduces the bending stresses at the weld and moves the maximum stress away from the weld heat affected zone into the parent material. It was also verified that bellows cores with tilt angles close to 45 degrees had superior fatigue resistance [5, 6].

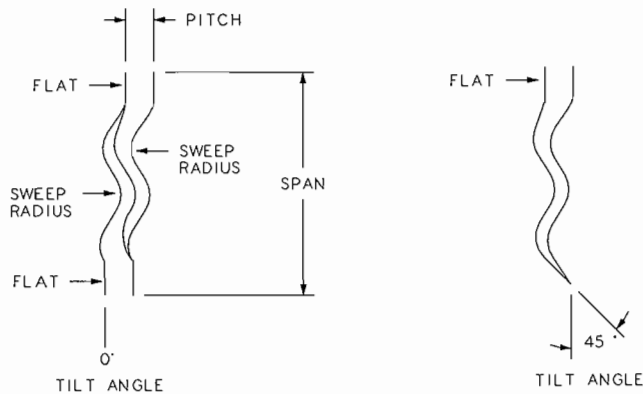

Figure 5. Flat Plate vs Plate with ID Tilt Angle.

SEAL FACE STABILITY

The service life and performance capabilities of mechanical seals depend on optimization of the mechanical contact forces as defined by Equations (1) and (3). Controlling or determining the mechanical contact forces becomes difficult as small deflections in the seal ring insert or stationary ring alter the pressure gradient factor between the seal faces. Factors that contribute to these deflections include pressure distortion of the entire insert, thermal distortion due to heat generated at the faces, and thermal distortion due to stress relaxation of interference fits in the shell/insert configuration.

Traditional Design

It is common practice, with present state-of-the-art metal bellows seal technology, to use a single interference fit to prevent fluid leakage between the seal ring insert and the shell. This traditional design is illustrated in Figure 6. Historically, the distortion that can be induced by stress relaxation of interference fit components, as described below, has been eliminated through material selection.

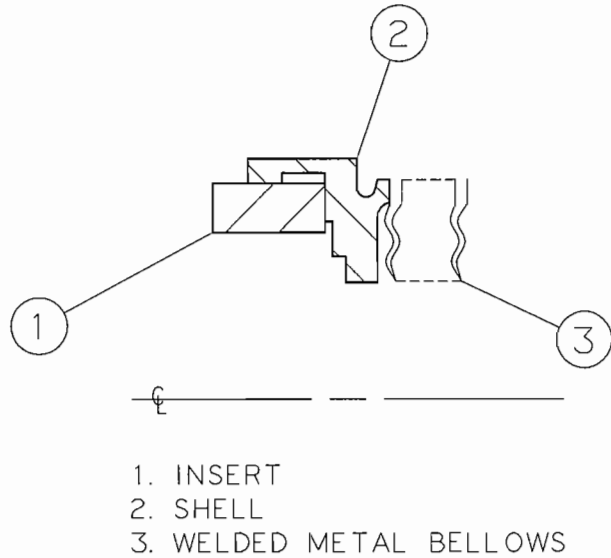

Figure 6. Traditional Shell/Insert Design for Metal Bellows Seal.

The single interference fit between the insert and the shell can cause a slight distortion at assembly, usually ID high. The seal is then lapped flat in this condition. As service temperature increases, the difference in the CTE between the insert and shell will cause a relaxation of the interference fit. Therefore, the insert returns to its original unstressed state, causing OD high distortion (K approaching 0). This leads to changes in the lubricating fluid film between the faces, which can result in excessive wear. The distortion at room temperature and at elevated temperature (interference fit stress relieved) is illustrated in Figure 7.

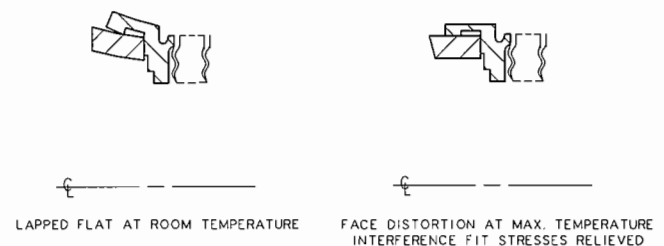

Figure 7. Schematic Representation of Distortion (traditional design).

To counteract the stress relaxation problem in high temperature applications, shell materials with CTE similar to that of the insert are selected. This affects the shell/insert arrangement in two ways. First, the interference fit distortion resulting from assembly is reduced, because less interference is required to hold the insert and provide driving torque. Second, relaxation of the interference fit stress that occur as temperature increases is reduced because the insert and shell tend to expand together. Although this approach

reduces stress relaxation problems, in corrosive applications it is difficult to select a material with both low CTE and good corrosion resistance.

Decoupled, Balanced Interference Fit Design

Using FEA, the shell/insert configuration was optimized such that distortion resulting from temperature and pressure can be controlled. The resulting new design is shown in Figure 8. This design uses an interference fit in two places; at the base of the insert and at the nose of the insert where a compensating ring is located. This arrangement provides an evenly distributed load around the centroid of the insert and eliminates uneven face distortion.

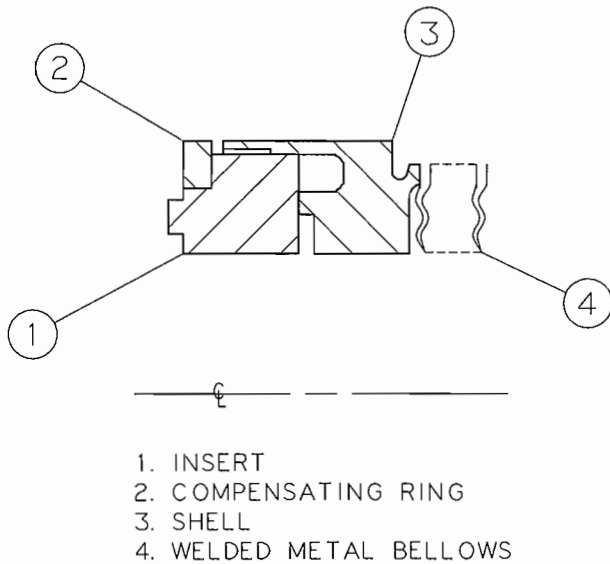

Figure 8. Typical Decoupled, Balanced Interference Fit Design.

During assembly, the applied stresses distort the insert around its centroid. As temperature is increased, the interference fit stress on the insert is relieved due to the difference in CTE of the dissimilar materials. The compensating ring on the nose of the insert effectively counterbalances the stress relieved by the shell, thus producing radial displacement of the insert while maintaining face flatness. This net distortion is illustrated schematically in Figure 9. In addition, the shell and compensating ring are not connected (decoupled), thereby eliminating distortion due to axial thermal growth of the shell that would tend to cause OD high distortion (K approaching 0).

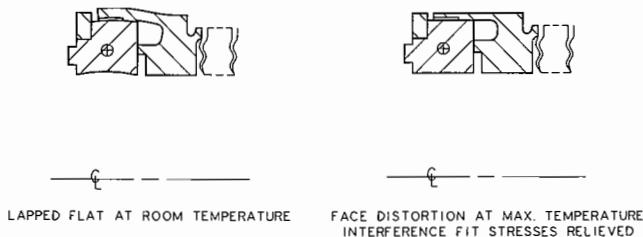

Figure 9. Schematic Representation of Distortion (decoupled, balanced interference fit design).

The shell, illustrated in Figure 8, uses a unique hinge and back-cut concept to control the interference fit stress applied to the insert. By making the hinge relatively long and with as narrow a

radial cross section as possible, the majority of the deflection from the interference fit is transmitted into the hinge, not the insert. This results in greater control over insert distortion as increasing temperature relaxes the shell/insert interference fit. Care must be taken not to exceed the materials yield strength at the area of highest stress in the hinge. The relief area at the end of the hinge acts as a stiffening ring. This controls the deflection of the hinge and evenly distributes the applied stress throughout the interference fit contact area. The hinge concept eliminates line contact, as depicted in Figure 7, by controlling the distortion from the interference fit. The back-cut reduces the stiffness of the shell and further decreases the stresses applied to the insert. The combined effect of the hinge and back-cut design reduce the stress applied to the insert without reducing the interference fit.

Distortion at the nose of the insert is controlled by the compensating ring. Optimization of the size, shape, and ultimately the relative stiffness of the ring allow it to effectively counterbalance the stress relaxation that occurs as temperature increases. The compensating ring also provides a self-correcting feature during operation. Because of its closer proximity to the faces, it becomes hotter than the shell during periods of poor lubrication. Therefore, the interference fit stress at the nose is relieved, causing a slight ID high distortion. This in turn allows more fluid between the faces, thus cooling the surfaces and contracting the ring to an equilibrium position.

The effect of pressure on face distortion was also considered in the development of the decoupled, balanced interference fit design. Hydraulic pressure forces acting on the OD of the bellows combined with the forces resulting from axial compression of the bellows act to create axial and radial reaction forces (F_x and F_y from Figure 2) at the shell/bellows weld joint. The resulting face distortion can be controlled by positioning the shell/bellows weld joint at an optimum location relative to the centroid of the insert.

FINITE ELEMENT ANALYSIS OF NEW SHELL/INSERT DESIGN

The nonlinear FEA program used gap friction interface elements to model the contact regions between the shell, compensating ring and insert. These elements represent two surfaces that may maintain or break physical contact and may slide relative to each other. They are capable of supporting only compression in the direction normal to the surfaces and model shear forces in the tangential direction. An iterative procedure was adopted to find the solution for a given geometry. Convergence occurred whenever the status of all elements remained unchanged from the previous status. The distortion is shown in Figure 10 of the new decoupled, balanced interference fit shell/insert arrangement at room temperature and zero pressure after the interference fit stress is applied.

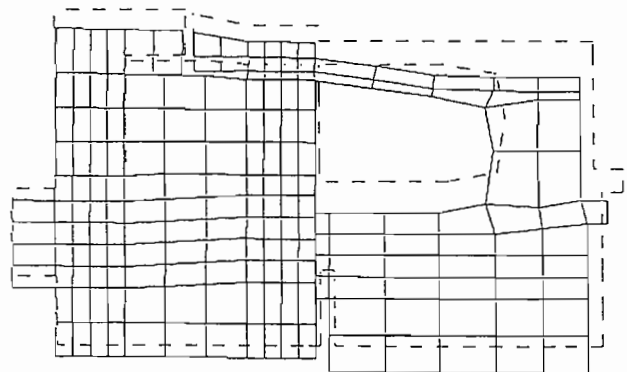

Figure 10. FEA Deflection Map at 70°F, 0 PSI.

The dotted outline represents the insert in its original state and the solid lines depict the insert after the stresses are applied. The distortion of the insert at 800°F and 300 psi is illustrated in Figure 11. It can be seen that the face distortion under combined loading is slightly divergent (ID high). Both diagrams indicate that most of the distortion occurs in the radial direction.

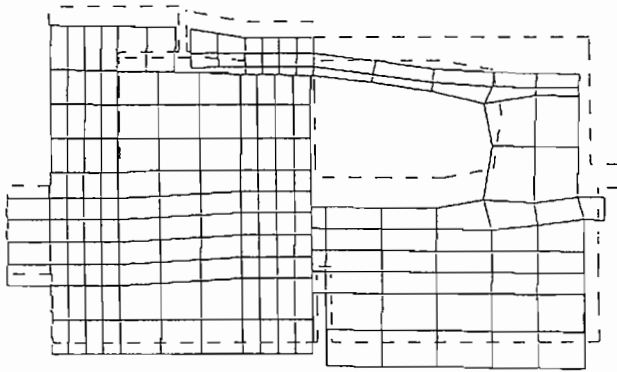

Figure 11. FEA Deflection Map at 800°F, 300 PSI.

EXPERIMENTAL DETERMINATION OF FACE DISTORTION

An optical flat test rig was built to measure static seal face distortion as a function of seal OD pressure and ambient temperature. The rig, shown schematically in Figure 12, consists of an optical flat with a very low CTE, positioned over a test chamber that can be pressurized to 300 psi and heated to 500°F. By positioning the seal face against the optical flat, it is possible to measure accurately seal face distortion caused by pressure and temperature.

To further illustrate the effects of pressure on the shell/insert configuration, a pressure testing rig was constructed per the design illustrated in Figure 13. By installing a seal in the chamber and then

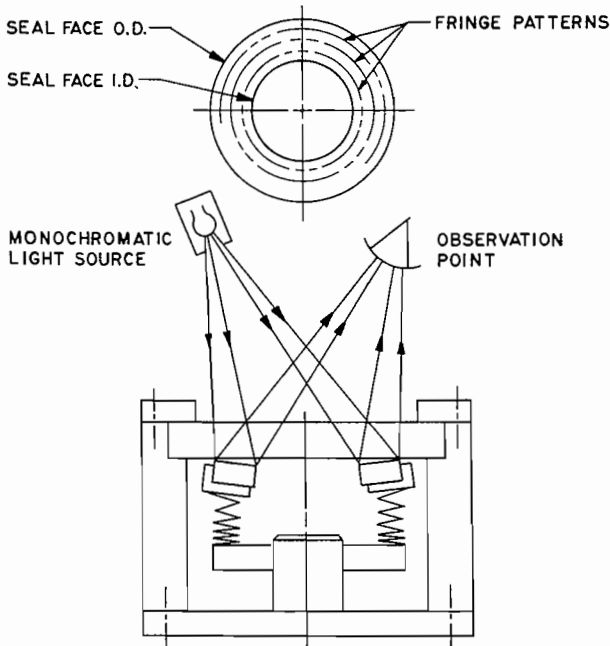

Figure 12. Optical Flat Face Distortion Test Rig.

pressurizing and rotating the shaft, the effects of pressure on the seal ring wear pattern can be visualized. The wear track produced by a traditional shell/insert configuration is compared in Figure 14 to the new design with 300 psi of applied pressure. The wear track of the traditional design is OD high while the wear track from the new design is consistent across the interface. This shows that the new design is able to control distortion resulting from hydraulic forces in high pressure applications.

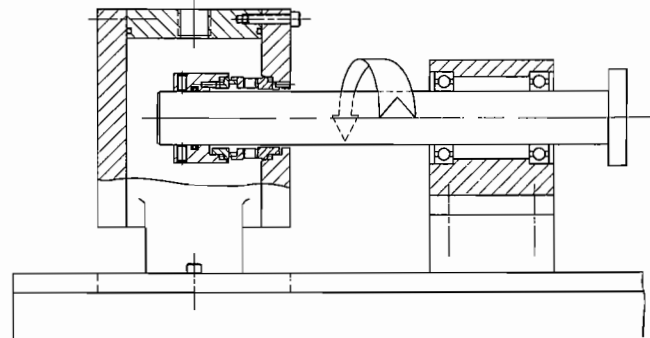

Figure 13. Pressure Test Rig.

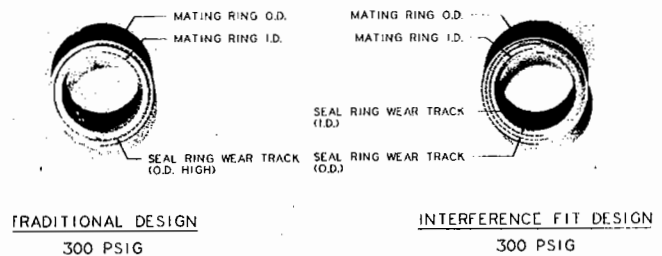

Figure 14. Wear Track Comparison (traditional vs decoupled, balanced interference fit).

The optical flat test rig and the pressure testing rig made it possible to correlate the results predicted by the FEA analysis. The results, organized in Table 1, show that the results from actual experimental tests agree well with the FEA predictions.

Table 1. Pressure and Temperature Distortion Results.

	PRESSURE		TEMPERATURE	
	ACTUAL	FEA	ACTUAL	FEA
TRADITIONAL	OD	OD 8 HLB	OD 7 HLB	OD <<1 HLB
D.B.I.F.	FLAT	ID <1 HLB	OD 1.5 HLB	ID <<1 HLB

APPLICATIONS WHERE THE NEW DESIGN PROVIDES SUPERIOR SERVICE

High Temperature, Corrosive Applications

Shell material selection with the traditional single interference fit insert is limited to materials with a CTE similar to those of the insert materials. Unfortunately, it is difficult to find a shell material that has both good corrosion resistance and a low CTE.

Since this new design controls face distortion through the optimization of the shell/insert design, selecting materials with

similar CTE is not as critical. This allows the shell and compensating ring in the new design to be constructed from high strength materials with superior corrosion resistance properties.

Combined with metal bellows also constructed of a high strength corrosion resistant alloy, the decoupled, balanced interference fit design provides improved reliability for sealing high temperature corrosive applications by eliminating corrosive failures. This is of particular interest to refineries that are processing high sulfur crudes.

Light Hydrocarbon Service

Another difficult application, where this design is being tested, is light hydrocarbon service. Here, heat generated at the seal interface must be minimized to prevent the fluid from flashing to a vapor between the seal faces. The new design can increase seal life by controlling face distortion, which directly affects mechanical contact forces and heat generation.

Typically, light hydrocarbon applications involve service pressures above the recommended limits of standard single ply metal bellows. In these cases, the pressure handling capability of the bellows must be enhanced by either increasing the plate thickness of the single ply bellows or incorporating the use of laminated or multiple ply bellows construction [7].

It has been determined in laboratory tests that multiple ply bellows exhibit higher static burst pressures and lower spring rates than single ply bellows constructed with a plate thickness that is twice that of each individual multiple ply plate (i.e., 0.003 in multiple ply bellows core plate thickness vs 0.006 in single ply bellows core plate thickness). Lower spring rates are desirable, because slight changes in the seal operational length result in very small changes in the face load. This is particularly important in light hydrocarbon applications where the control of face load is extremely critical.

Another problem associated with light end applications is vibration from pump cavitation. The individual plies, of the multiple ply bellows, are believed to contact when vibrations from operational upsets occur, thus acting to dampen or stabilize vibrational effects.

FIELD TESTING RESULTS

The success of this new design is best demonstrated by examining a high temperature, corrosive application where conventional seals typically failed in three to six months. The primary cause of failure was due to corrosion of the low expansion alloy 42 shell to which the insert was attached with a traditional type, single interference fit.

The test seal for this application used the decoupled, balanced interference fit design constructed of heat treated Inconel 718™, which was chosen for its corrosion resistance and superior strength

at high temperatures. In order to verify seal face stability, the seal was analyzed by FEA methods and tested in the optical flat rig as previously described. The seal was installed in June 1990 and has run continuously to date with no detectable leakage.

CONCLUSION

By correlating experimental testing with FEA results, a new shell/insert arrangement has been developed and proven to minimize face distortion resulting from changes in temperature and pressure. This design, when used with bellows plate shapes that have been optimized for uniform stress and fatigue strength, is the optimum seal arrangement for high temperature, corrosive services. Superior face stability and extended life are provided by design, rather than material selection. This allows for the use of high strength, corrosion resistant alloys in the construction of the shell/insert.

The new optimized design is also being field tested for service in light hydrocarbon applications where maintaining face stability, mechanical contact pressure, and reducing heat generation are extremely critical.

REFERENCES

1. O'Dell, C.W., Wickersham, C.P., and Gaines, A., "SiC Face Bellows Seals in Critical Process Pumps Will Save \$25,000/Year," *Chemical Processing Magazine* (February 1983).
2. Jones, H.H., and Molnar, J., "Metal Bellows Seal Has Extended Life in High Temperature Application," *Plant Services Magazine*, p. 24 (September 1987).
3. Gardner, J.F., "Balanced Shrink Fit Seal Ring Assembly," U.S. Patent No. 5,042,824 (August 1991).
4. Datta, A., Gardner, J.F., Derby, J.U., and Casucci, D.P., "Metal Bellows Mechanical Face Seals For High Performance Pump Applications," *Proceedings of the Fifth International Pump Users Symposium, Turbomachinery Laboratory, Department of Mechanical Engineering, Texas A&M University, College Station, Texas*, pp. 27-40 (May 1988).
5. Hulbert, L.E., et al., "Final Report on the Development of Analytical Techniques for Bellows and Diaphragm Design," AFRPL-TR-8-22 (March 1968).
6. Hulbert, L.E., et al., "Final Report on the Development of the Tilt-Edge Bellows Concept," AFRPL-TR-70-115 (October 1970).
7. Krokell, R., "Laminated Metallic Bellows," U.S. Patent No. 3,090,403, (May 1963).