

API 685 TUTORIAL

by

Shawn L. Bennett

Engineering Manager, Pump Applications

Sundyne Corporation

Arvada, Colorado

and

Jim E. Bryant

Technical Professional Manager, Machinery Technology

KBR

Houston, Texas



Shawn L. Bennett is Engineering Manager, Pump Applications, for Sundyne Corporation, in Arvada, Colorado. During her eight years with Sundyne, she has primarily focused her efforts on sealless pump technology. Prior to joining Sundyne, she worked for ExxonMobil, in Chalmette, Louisiana, as a refinery Process Engineer. Unit responsibilities included: cracking, reforming, hydrotreating, alkylation, sulfur recovery, and utilities.

Ms. Bennett holds a B.S. degree (Chemical Engineering and Petroleum Refining) from the Colorado School of Mines. Additionally, she earned an MBA degree (Technology Management) from the University of Phoenix.



Jim E. Bryant is a Technical Professional Manager in Machinery Technology at KBR, in Houston, Texas. He is responsible for supervising work and providing technical assurance on projects for chemical, refining, polymers, specialty chemicals, and gas industry services. Mr. Bryant has more than 30 year's experience with mechanical equipment, the last 23 with KBR or a KBR legacy company. His responsibilities include specification, evaluation, testing, and

technical support, primarily in the area of rotating equipment.

Mr. Bryant holds a B.S. degree (Mechanical Engineering, 1972) from Texas A&M University. He is KBR's representative on the API Subcommittee on Mechanical Equipment, Chairman of API 672 and API 685, and a member of API 610 Task Force. He is a registered Professional Engineer in the State of Texas.

ABSTRACT

For the first time, there is an API standard relating to the use of sealless pump technologies [canned motor pump (CMP) and magnetic drive pump (MDP)]. While sealless technology has been well accepted in chemical process applications, it has not been well adopted in the API market. The lack of an API specification certainly has been a contributing factor to this lack of acceptance. The API market tends to wait for a technology to be fully proven and commercialized prior to considering adoption of the product. However, the API industry is fully committed to utilizing the best technology available to protect plant personnel and the environment.

INTRODUCTION

API 685 (2000) covers sealless centrifugal pumps for petroleum, heavy-duty chemical, and gas industry services. API recommends the use of API 685 (2000) for sealless services with the following factors:

- Discharge pressures greater than 275 psig (1900 kPa)
- Suction pressures greater than 75 psig (500 kPa)
- Pumping temperatures greater than 300°F (150°C)
- Rotative speeds greater than 3600 rpm
- Rated total head greater than 400 ft (120 m)
- Maximum impeller diameter greater than 13 inches (300 mm)

Parameters that exceed the above stated ranges are solid criteria for determining when a heavy-duty pump is required. However, API does not give guidelines on when a sealless pump should be considered. Sealless technology is well suited for the following applications:

- Lethal
- Toxic
- Flammable fluids
- Expensive fluids
- Fluids with dissolved solids (i.e., caustic)
- Carcinogenic
- Heat transfer fluids (hot and cold)
- Emissions are regulated
- Fluids that are difficult to seal

Increasingly stringent environmental requirements surrounding volatile organic compounds (VOC) have led to the increased use of sealless technology. A thorough, unbiased evaluation and application of the appropriate sealless technology results from carefully evaluating both technologies [canned motor pump (CMP) and magnetic drive pump (MDP)]. There are many refinery applications ideally suited to sealless technology. The following are a few examples of where sealless technology is being applied in refineries currently.

- Hydrofluoric acid (HF acid)
- Anhydrous hydrofluoric acid
- Naphtha
- Sulfuric acid
- Butane
- Isobutane
- Methanol
- Caustic
- Propylene
- Alkylate
- Methyl mercaptan
- Aromatics (benzene, xylene, toluene)

- Sour water (water containing H₂S)
- Olefins

Process units that would pump the above fluids (pure or as a mixture) are varied and could include:

- Alkylation (HF acid or sulfuric acid)
- Sulfur plant
- Aromatics recovery unit
- Hydrotreaters
- Boilerhouse
- Hydrocracker
- Fluidized catalytic cracker (FCC)
- Reformer
- Crude

KEY HIGHLIGHTS FROM API 685

- Stringent forces and moments
- Rotating assembly balancing to G1.0 ISO 1940
- Vibration (less than 0.12 in/sec rms/3.0 mm/sec rms)
- ASME, Section VIII, Division 1 or 2 (pressure containing components)
- Corrosion allowance
- Performance requirements
- Head (-2/+5 percent to -2/+2 percent, depending on overall head)
- Power (+4 percent)
- NPSHr (+0 percent)
- Pressure versus temperature profiles
- Centerline mounting required for all horizontal MDP
- Centerline mounting required for horizontal CMP above 350°F
- API baseplates required for horizontal mounted units

Key Application Data Required (By Customer)

- NPSHa
- Temperature versus vapor pressure curve
- Temperature versus viscosity curve
- Specific heat
- Specific gravity

In order to make a sound pump selection, it is important to make sure all process conditions are supplied to the pump vendor. API 685 refers to specific responsibilities of the pump user/contractor, and it is important that this information is shared with the pump vendor. A detailed vapor pressure margin analysis is critical to the success of many volatile fluid applications found in refinery applications. It is essential that the fluid remain a liquid throughout the full pump circuit. Hence, a full vapor pressure versus temperature curve is required to make an accurate comparison of the data. The vapor pressure and specific heat must be reflective of the pure fluid or mixture. A single point vapor pressure does not allow for the application to be evaluated at the elevated temperatures experienced in the motor or pump containment section of a sealless pump.

TECHNOLOGY COMPARISON (CMP VERSUS MDP)

Often times the decision to choose CMP or MDP technology is based upon customer preference. The biggest difference between the two technologies is absolute secondary containment (CMP) versus secondary control/containment (MDP). The application pyramid in Figure 1 also helps to explain where a CMP versus MDP is typically applied. Canned motor pumps are typically applied as an application moves up in toxicity. Magnetic drive pumps are applied in the center and lower section of the pyramid. However, the technology can certainly be applied lower down the pyramid if desired.

The decision tree on when to think sealless can be based upon the simplified flowchart shown in Figure 2. Additionally, this flowchart describes some key factors to consider when deciding between CMP and MDP technology.

Technology Pyramid

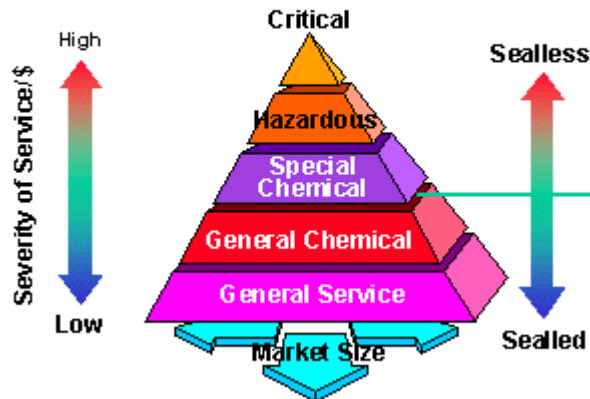

Figure 1. Sealed Versus Sealless.

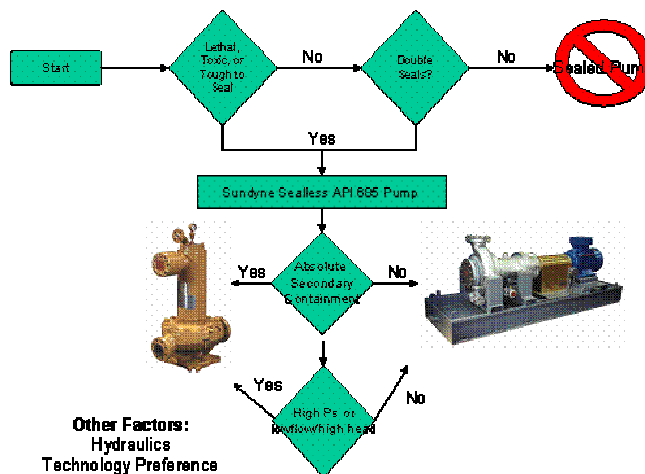

Figure 2. CMP Versus MD.

Canned Motor Pump Technology

The features of a canned motor pump are absolute secondary containment and an integral motor. Canned motor pumps are classified as totally enclosed liquid cooled (TELC). With canned motor pump technology, shaft alignment is inherently not required since there is only a single shaft. Canned motor pumps are inherently low noise and require nominal space requirements. CMP technology can be coupled with variable frequency drives (VFD) to run the pump above synchronous speed to achieve higher heads with smaller hydraulics. VFD technology also allows for tremendous operating flexibility, elimination of control valves, and energy savings.

Key Highlights of API 685 for Canned Motor Pump Technology

- Secondary containment
- ASME Section VIII design (motor housing) with 1/8 inch corrosion allowance
- Motor testing to include resistance measurement and dielectric
- Forces and moments to meet twice the requirements indicated in the specification
- Centerline mounting is required for horizontal units > 350°F (177°C)
- Stator housing to be designed to match pressure casing matching allowable working pressure (MAWP) at operating temperature (including the electrical feed through)
- Stator liner thickness to be a minimum of 0.46 mm/.018 inch with a corrosion allowance of 0.15 mm/0.005 inch

- Rotor liner corrosion allowance to be a minimum of 0.15 mm/0.005 inch

Sample Vapor Pressure Versus Temperature Profiles

From the pressure versus temperature profiles shown in Figures 3 and 4, it is clear the vapor pressure has a big affect. In Figure 4, the vapor pressure is greater than circuit pressure indicating that flashing is occurring (at points D, E, and F). It is essential that this pressure versus temperature evaluation be performed for all sealless applications.

Vapor Pressure Margin Curves

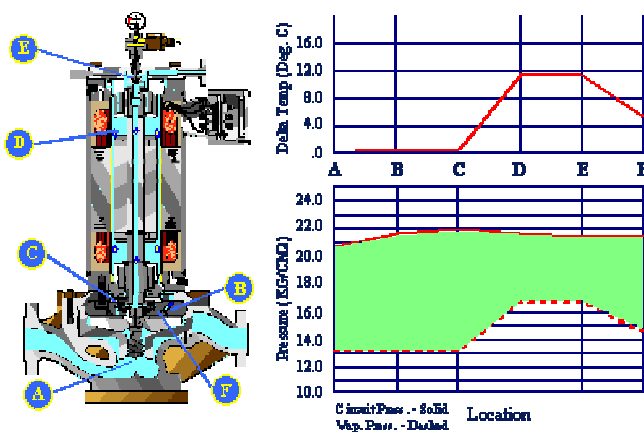

Figure 3. Adequate Vapor Pressure Margin.

**Vapor Pressure Margin Curves
Model - HP - C3 Splitter Feed - Item D**

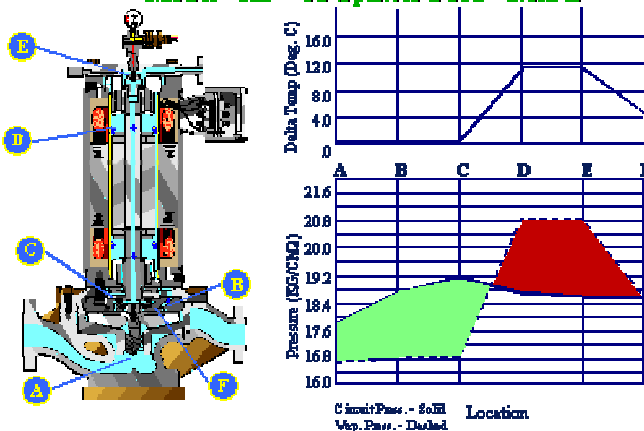

Figure 4. Vapor Pressure Greater than Circuit Pressure.

API 685 MAGNETIC DRIVE PUMPS

API 685 covers both magnetic drive pump configurations (synchronous and asynchronous). The synchronous style unit is available up to 500°F (205°C). The synchronous drive comprises an outer magnetic ring assembly (OMR) built to magnetically couple with an inner magnetic ring assembly (IMR). These two magnet rings are locked together by the flux of attracting magnet poles flowing through the containment shell. The magnet/magnet coupling is therefore a fixed speed drive and has a constant torque performance.

For higher temperature applications above 500°F (260°C), a torque ring configuration is utilized. The torque ring drive is similar in method to the synchronous drive except the inner magnet ring is replaced in this drive system with a special torque ring (series of copper bars). Magnetic eddy currents are created that rotate the

torque ring. Since there are no magnets in the process liquid, torque ring pumps can operate up to 662°F (350°C) without cooling.

Key Highlights

- Centerline mount
- Synchronous or asynchronous configuration
- Rare earth or aluminum nickel cobalt magnets
- Outer and inner magnetic rings must be mechanically retained
- API baseplate
- Secondary control options
- Impeller and pump case wear rings
- Drive end and pump driver must be removable without disturbing the pressure casing
- Pump design to protect the outer magnetic ring (OMR) from contacting the containment shell if a shaft or bearing fails

The pressure versus temperature diagram (Figure 5) indicates the pump circuit pressure (head) is greater than the vapor pressure of the liquid. This indicates the fluid is remaining a liquid throughout the full flow path, which is the criterion for an acceptable sealless application.

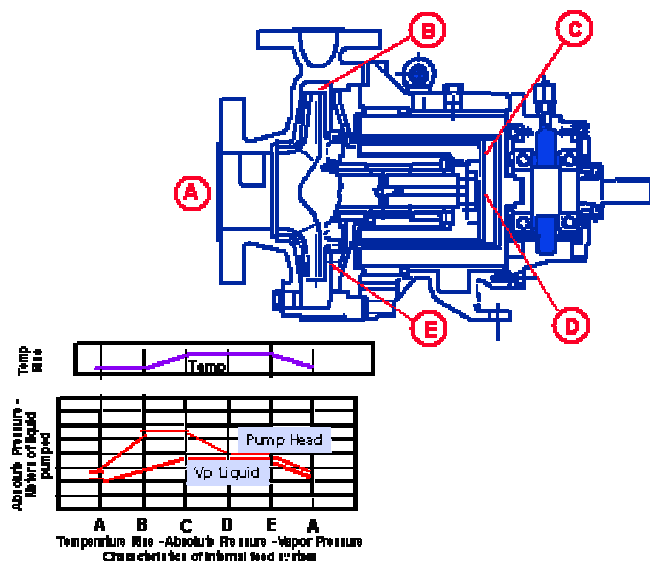

Figure 5. Magnetic Drive Pressure Versus Temperature Profile.

**APPENDIX A—
JUSTIFICATION FOR DEVELOPMENT OF API 685**

Section 111 of the Clean Air Act (1990), as amended in 1977, directed the US Environmental Protection Agency (EPA) to set standards of performance for newly constructed, modified, or reconstructed sources of air pollution that may endanger public health or welfare. These New Source Performance Standards (NSPS) were to be issued to dozens of industries recognized to have significant emissions and public risk. The ranking of these industries was issued in 1979, and the Synthetic Organic Chemicals Manufacturing Industry (SOCMI) was first on the list. Parallel to this regulatory development, fugitive emissions of volatile organic compounds were being assessed from petroleum refineries. Fugitive emissions refer to leaks of VOC from equipment such as valves, pumps, compressors, pressure relief devices, and connectors. In 1981 the first NSPS for fugitive emissions was proposed and later finalized in October of 1983 (40 CFR 60.480, Subpart VV). These regulations for fugitive leak detection and repair (LDAR) raised environmental consciousness for the hydrocarbon processing industry, as did later LDAR regulations for petroleum refineries after their NSPS were finalized in May 1984 (40 CFR 60.590, Subpart GGG) and the onshore natural gas industry LDAR NSPS for fugitives in June 1985 (40

CFR 60.630, Subpart KKK). Additionally, there have been incidents that added to concerns such as: the 1984 accident in Bhopal that killed over 2000, the 1989 accident at Phillips Chemical, the accidents at both Arco and BASF in 1990.

Avoidance of regulatory applicability required installation of double and tandem sealed pumps, though some state agencies had even more restrictive requirements. California's 500 ppm limits for definition of a leaker were being followed by several states, and local bodies were historically more restrictive than federal standards. Terms like maximum achievable control technology (MACT, used after 1990 Clean Air Act Amendments) for hazardous air pollutants, and best available control technology (BACT, required under some new source permitting regulations) were being used and no one knew what constituted compliance. Sealless pump technology was also a viable alternative to regulatory applicability. It had been proven in the chemical industry and was being fairly widely used in Europe. There seemed to be ample justification for extending the technology to heavy-duty process pumps, and several manufacturers had initiatives to develop such products.

This is the primordial soup that gave rise to a project justification to develop a sealless pump standard for the API sector. 685 was the standard number assigned. Chevron's David Mooney "volunteered" to be the Task Force Chairman, and he solicited both participants and company specifications for sealless pumps.

TASK FORCE COMPOSITION

The Task Force was composed of (Figure A-1):

- Chemical companies:
 - Chevron Chemical
 - Exxon Chemical Company
 - Hoechst Celanese Company
 - Tennessee Eastman Company
- Oil companies
 - Amoco Oil
 - Arco
 - Mobil Oil
 - Shell Canada Limited
 - Ultramar
- Contractors
 - Bechtel
 - Fluor Daniel, Inc.
 - Foster Wheeler USA
 - M.W. Kellogg Company
- Manufacturers
 - (Synchronous) Magnetic drive
 - Dresser Pump
 - Goulds Pump
 - IMO Pump
 - Ingersoll Rand
 - Iwaki Walchem Company
 - Sulzer Bingham Pump
 - Union Pump
 - Wilson Snyder Pumps
 - Canned motor
 - ABS Pumps/Lawrence Pump & Engine
 - Crane Chempump
 - Sundyne
 - Synchronous and eddy current drive
 - HMD/Kontro Company

RESOURCES USED TO DEVELOP API 685

Starting documents from which API 685 was developed included (Figure A-2):

- API 610, Seventh Edition
- API Standard Paragraphs R20
- Company specifications from: Chevron, Dupont, Exxon, Mobil, Texaco

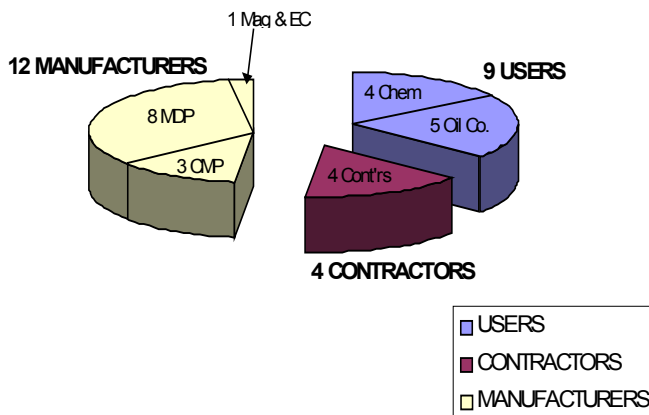

Figure A-1. Task Force Composition.

- Contractor specifications from: Bechtel, Brown & Root, M.W. Kellogg
- Hydraulic Institute Sealless Centrifugal Pump Standards
- ANSI B73.3 and 73.4
- EEMUA Pub 164 Class 1

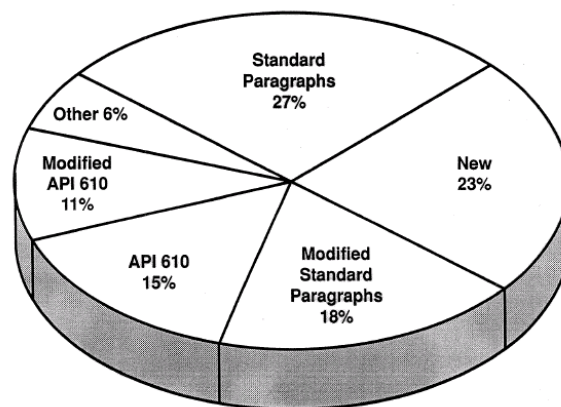

Figure A-2. Sources of Paragraphs in Draft 2 of API 685.

TIMELINE ON 685 DEVELOPMENT

The effort for development of API 685 occurred in three distinct spurts. The first was a "normal" development plan for a new standard.

Requested user and contractor specifications:	Jun 91
Initial organization meeting:	Aug 91
Prepare first draft:	Sep 92
Prepare second draft (to SP R20) for subcommittee review:	Feb 93
Formal subcommittee review:	May 93
(Publication deferred for API 610, Eighth Edition)	
Fourth draft incorporating all review comments:	Jul 93
API 610, Eighth Edition, presented to subcommittee:	Sep 93

Second Push

After the presentation of the draft to the Mechanical Equipment Subcommittee in Toronto, and handling of comments received during the presentation, the decision was made by the Mechanical Equipment Subcommittee to defer publication of API 685 until after publication of API 610, Eighth Edition (1995) (and API 682, First Edition). One reason was that Eighth Edition was a major stride forward to gain international acceptance of the API standards. This included dual units and reference to ISO standards. This was thought to be important to API 685 since sealless pumps had a more established market in Europe.

In addition to the delay, following the format of API 610 also required a significant effort in reformatting since API 685 had been developed to API Standard Paragraphs R20, whereas API 610 had been developed to R19. Having the two standards parallel each other to the extent possible would facilitate a possible future integration of API 685 into API 610. Even though the Eighth Edition was presented in September 1993, API 685 did not resume until API 610 had dealt with all the review comments received. API 685 resumed in the summer of 1994 under a new Task Force Chairman, Richard Beck with Chevron.

Publication of API 682:	Oct 94
Fifth draft (reformatted to parallel API 610/SP R19 and incorporate references to International Standards):	Dec 94
API 610, Eighth Edition published:	Aug 95
Sixth draft incorporating Task Force comments submitted for subcommittee ballot:	Oct 95
Ballot suspended before deadline, comments received processed:	Aug 96
Seventh draft sent out for rebalot:	Nov 96

Third Push

Following rebalot, the effort took another hiatus. This was due in part to Mr. Beck going on a foreign assignment, and partially to lost momentum from the success of API 682 to satisfy both the reliability issues with mechanical seals and the emission limitations by oversight authorities. However, in late 1998 Jim Bryant with M.W. Kellogg was tagged to complete the effort.

Because of the time lapse, there were several obstacles to the effort:

- The demand/market had not materialized for sealless pumps and development efforts had been halted by some manufacturers.
- Mergers had reduced the number of manufacturers involved.
- Many former Task Force members had changed jobs or responsibilities.
- Access to originals of many of the figures and appendices had been lost.
- Much of the R19 based text had been improved with issue of Standard Paragraphs R22.

Task Force reactivated:	Feb 99
Received subcommittee agreement on comments to ballot (recreated figures and appendices):	May 99
Final draft submitted to API Editors:	Oct 99
Galley proofs received for review (formatted to R22):	Feb 00
Second galley proofs received for review:	Apr 00
Third galley proofs received for review:	Jul 00
Published:	Oct 00

OVERVIEW OF API 685 REQUIREMENTS

As most have a basic familiarity of API 610 requirements, this paper covers the major requirements and features that are different from those in API 610, Eighth Edition (1995).

Applicability

API 685 is applicable to sealless centrifugal pumps for the petroleum, heavy-duty chemical, and gas industry services. It specifically covers overhung, single-stage pumps (horizontal and vertical) of the canned motor, synchronous magnetic drive, and asynchronous (eddy current) magnetic drive types. It was intended to be the sealless equivalent of the API 610 single-stage overhung process pump (Figure A-3). It ignores other API 610 pump types, specifically between bearing horizontal pumps and vertically suspended pumps.

API 685 recognizes (as does API 610, Ninth Edition) that purchasers may wish to consider (sealless) pumps that do not comply with API 685 for process services with:

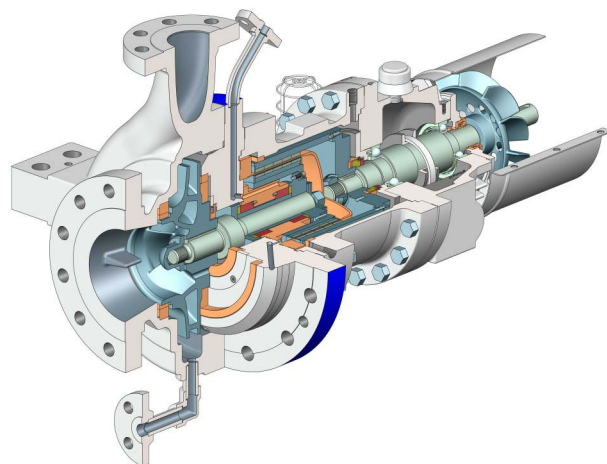

Figure A-3. Typical API 685 MDP.

Maximum discharge pressure:	275 psig
Maximum suction pressure:	75 psig
Maximum pumping temperature:	300°F
Maximum rotative speed:	3600 rpm
Maximum rated total head:	400 ft
Maximum impeller diameter:	13 inches

Definition of Terms

Requirements of API 685 required numerous definitions not found in API 610 (Table A-1, Figure A-4).

Table A-1. Definition of Terms.

Air gap (3.1)	Journal sleeve (3.21)	Rotor liner (3.61)
Axial thrust (3.2)	Liquid end (3.22)	Sealless pump (3.62)
Canned motor pump (3.5)	Liquid gap (3.23)	Secondary containment (3.63)
Containment shell (3.6)	Locked rotor torque (3.24)	Secondary containment system (3.64)
Coupling (magnetic) (3.7)	Magnetic drive pump (3.25)	Secondary control (3.65)
Decouple (3.10)	Outer magnet ring (3.47)	Secondary control system (3.66)
Demagnetization (3.11)	Pole (3.49)	Secondary pressure casing (3.67)
Eddy current losses (3.14)	Power end (3.50)	Sleeve bearing (3.68)
Electrical feed-through barrier (3.15)	Primary pressure casing (3.51)	Slip (3.69)
Hydraulic thrust bearing (3.16)	Product lubricated bearings (3.52)	Stator housing (3.73)
Hysteresis (3.18)	Radial loading (3.54)	Stator liner (3.74)
Inner magnet ring (3.19)	Rotor chamber (3.59)	Tolerance ring (3.79)
Inner magnet sheathing (3.20)	Rotor chamber temperature rise (3.60)	Torque ring drive (3.80)

Critical Design and Application Considerations (6.2)

Many early installations of sealless pumps were tarnished by unrealistic expectations and misapplication. API 685 has a section to emphasize the importance and responsibility of communicating information about the services—items that probably should have been aired for all pump services, but were not as critical for sealed pumps. These include:

- Properties of the pumped fluid
 - Temperature/vapor pressure curve
 - Temperature/viscosity curve
 - Specific heat
 - Specific gravity
 - Thermal conductivity
 - Thermal expansion characteristics
 - Polymerization characteristics
- Solids present
 - Particle size
 - Percent solids
 - Particle distribution by size
- NPSHa
- System arrangement
 - Location of pump relative to suction vessel
 - Vessel arrangement
 - Piping arrangement

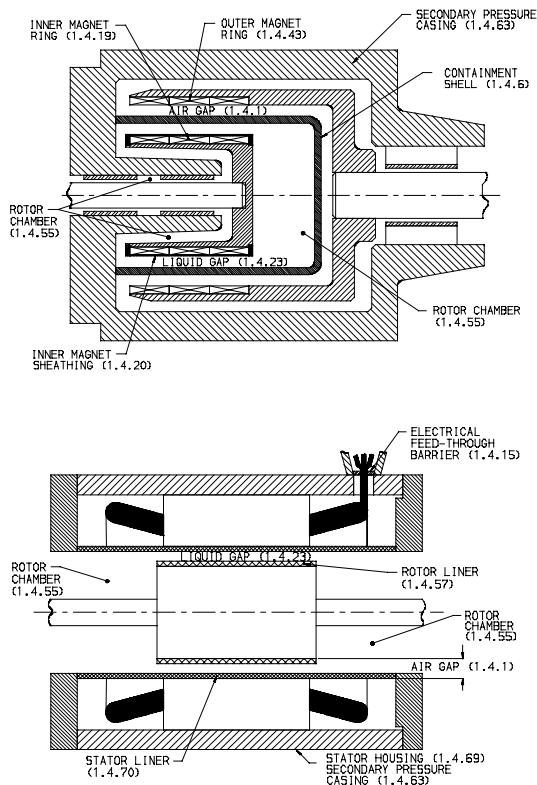

Figure A-4. Appendix C Illustrations of Terms Defined.

Information required of the vendor includes:

- NPSHr
- Temperature rise of the pumped fluid:
 - During operation
 - After shutdown
- Effect of wear on flow/temperature distribution
- Minimum continuous stable flow
- Minimum continuous thermal flow
- Temperature profile of the fluid recirculation flow path (Appendix K)
- Pressure profile of the fluid recirculation flow path (Appendix K)

Pressure Casings (6.3/9.1.2.1 and 9.2.3)

The pump volute requirements are the same as API 610, Eighth Edition (1995); the impact is on design of the pressure boundary between the primary and secondary casing. Because losses are related to the separation between magnets or rotor and stator, there is a need to avoid too much margin in thickness. More refined design techniques are used for the containment shell (MDP). In a CMP, the stator liner depends on backing supports in the stator for most of the pressure containment strength.

Nozzle and Pressure Casing Connections (6.4)

This section eliminates all mention of cast-iron connections since they are in conflict with most fluids handled in sealless pumps. Threaded connections are not allowed on the primary pressure casing.

Sections 6.5, 6.6, 6.7, and 6.9

Sections dealing with external nozzles force and moments, rotors, wear rings and running clearances, and rotordynamics have been pared down from API 610, Eighth Edition (1995), to apply to single-stage overhung pumps. Requirements for other pump types were removed.

Secondary Control/Containment (6.8)

The purchaser is to specify which option the pump shall have:

- **Secondary containment system**—is for the confinement (capture) of the pumped fluid within a secondary pressure casing in the event of a failure of the primary containment shell or stator liner. It includes provisions to indicate a failure of the containment shell or liner. Secondary containment is inherent with canned motor pumps so long as the electrical feed through barrier is properly designed. For magnetic drive pumps it requires either a double wall containment shell or a shaft seal in the secondary casing.
- **Secondary control system**—minimizes or safely directs release of pumped fluid in the event of failure of the primary containment shell or stator liner. It includes provisions to indicate a failure of the containment shell or liner. For a magnetic drive, it includes the further provision for a replaceable nonsparking restriction device (lip seal not acceptable) around the external shaft to minimize leakage. Secondary control is a nonissue for canned motor pump technology as it is expected the feed through barrier will be properly designed.

A further option for secondary containment or control is to include the leakage monitoring devices in the vendor's scope.

Secondary Containment Design with Monitoring

As an option, the pump end bearing isolator can be replaced with a maintenance-free, gas secondary seal. In this case a secondary containment chamber is formed together with the intermediate piece and the bearing bracket (Figure A-5). In normal operation the mechanical gas seal runs in standby as an unpressurized secondary seal. If the containment shell fails, the seal will be closed by the product pressure and the product will then be confined within this secondary pressure casing. The failure of the primary containment shell will be indicated by a liquid detector or a pressure switch.

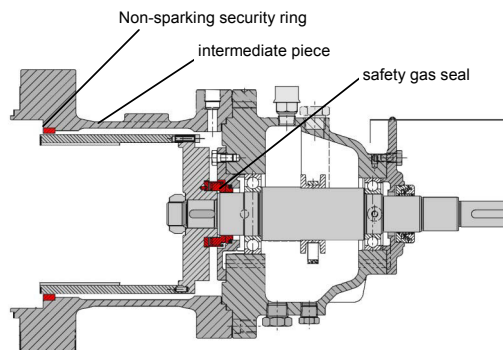

Figure A-5. Secondary Containment with Safety Mechanical Seal.

The secondary containment system is rated for the same pressure as the pressure casing. The secondary *control* system is required to have a standby life of at least 25,000 hours in a pump operating mode and has a functional design life of at least 24 hours in the event of containment shell failure. This should have applied to secondary containment as well (next issue?).

Special construction features of a typical gas seal are shown in Figure A-6.

A security ring is mounted in the intermediate piece (Figure A-5). In case of a failure of the outer rotor bearings the outer rotor will touch this ring (and not the shell). Temperature monitoring is optional (refer to later section, "Magnetic Drive Specific").

Process Cooled/Lubricated Bearings (6.10)

Another distinguishing requirement of sealless design is the application of bearings operating in, and depending on, the process fluid for cooling and lubrication. A clean liquid from an external source can be used with purchaser's approval. These bearings are of the precision-bored sleeve type.

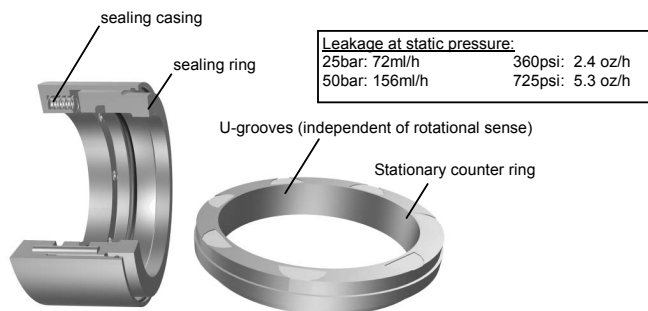

Figure A-6. Maintenance-Free Gas Seal.

Bearing materials are usually silicon carbide, tungsten carbide, or carbon. These materials often have much lower coefficients of thermal expansion than metal parts of the pump and require a radial clearance designed to accommodate relative thermal expansion. Tolerance rings are used to maintain position between dissimilar materials. Also, bearings normally have grooves for flushing of foreign particles and increased flow for heat removal. The following illustrates one design, but many variations exist.

The Product (Fluid) Lubricated Bearings (PLB)

The pump shaft (with impeller and inner rotor of the magnetic coupling) runs in product-lubricated, maintenance-free bearings (Figure A-7). Lubricating grooves are incorporated (Figure A-8). The self-adjusting bearings absorb axial thrusts and radial forces. The journal bearing is made of a highly wear-resistant, solid silicon carbide (SiC). Shrink-fitting them into the metal retainers ensures the SiC thrust plates' mechanical stability. The inner bore of the thrust plate centers the SiC shaft sleeve. That allows the SiC shaft sleeve to not have any contact with the shaft and therefore be independent of shaft growth due to temperature changes. Even if the radial bearing should fail, this design provides maximum reliability and serviceability during coastdown.

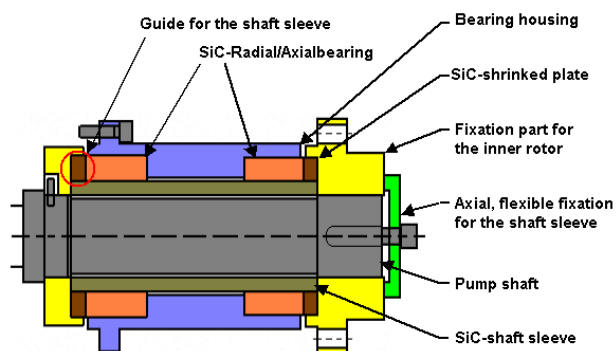

Figure A-7. Process Lubricated Bearings.

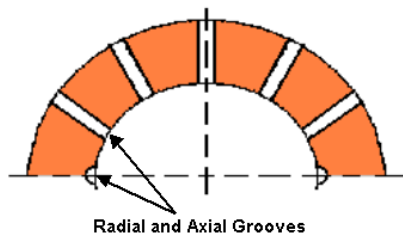

Figure A-8. View of Axial Thrust Bearing Plate. Circulation Through Groove Essential to Lubricate Bearing.

Circulation through the product lubricated bearing is essential to lubricate the bearing. A minimum viscosity of 0.2 mPas (cP) is required. Alternately, carbon graphite versus SiC sleeve may be used for lower viscosity with engineering approval.

Materials of Construction (6.11.1 and Appendix H)

The need for low hysteresis materials such as Hastalloy® and the reactivity of some fluids typically pumped in sealless pumps demanded an expanded (from API 610, Eighth Edition) materials table. Also, the need to assign minimum materials to previously undefined parts caused an expanded Appendix H. The minimum material for stator and rotor liners and for containment shell and inner magnet sheathing for all classes is 316L stainless steel. Cast-iron casings would not be used with the hazardous materials usually associated with sealless applications.

Protective Instrumentation (7.2.2.4)

It is the purchaser's option what instrumentation is supplied and whether it is supplied by the vendor or the purchaser, but the following instruments are recommended:

- Pump power monitoring to detect pump dry-run conditions (this is usually an amp monitor)
- Leakage monitoring in the secondary casing
 - Pressure measurement for flashing fluids
 - Optical moisture sensor for nonflashing liquids
- Temperature monitoring of the fluid circulating in the rotor chamber

Requirements from API 610

Applicable Only to Magnetic Drive Pumps

Several requirements of API 610 (1995) are applicable to magnetic drive pumps, but not canned motor pumps. These include:

- Antifriction bearings, bearing housings, and oil lubrication (9.1.4)
- Shaft couplings and guards (9.1.5.2)
- Separately coupled motor and turbine drivers (9.1.5.1)
- Heavy-duty baseplates (9.1.5.3)

Other Requirements Not Covered by API 610

Magnetic Drive Specific

• *Deflection criteria (6.3.7)*—Rather than concern for deflection at mechanical seal, mag-drive pumps are to have liquid and air gap clearances sufficient to avoid contact between the magnet assemblies and the containment shell even from pressure deformations, nozzle loading, and thermal expansion. A replaceable device of nonsparking material is required to prevent the outer drive magnet from contacting the containment shell in the event of a shaft or bearing failure.

• *Magnet materials (9.1.3.1)*—Developments of rare earth magnetic materials in the late 1980s improved the feasibility of synchronous magnetic drives (Figure A-9). API 685 specifies that synchronous magnetic couplings are to be supplied as rare earth magnets: neodymium-iron-boron (NdFeB) or samarium cobalt (SmCo). Asynchronous couplings are supplied as either rare earth or aluminum-nickel-cobalt (AlNiCo) magnets. AlNiCo is more temperature tolerant than rare earth magnets (Figure A-10). More information is given in Appendix I.

• *Sizing of magnets (9.1.3.7-8)*—In sizing the magnetic coupling, the manufacturer is to consider:

- The torque required to accelerate the motor during starting.
- The torque required for rated conditions plus allowance for future head or a speed increase for variable speed drives.
- Torque for end of curve operation such as transfer pumps, loading pumps, and pumps operating in parallel (only when specified).

Speed-Torque Curve (9.1.3.10)

When specified, the vendor shall submit a speed torque curve defining capability of the synchronous magnetic coupling during startup and operation at the rated temperature. The torque requirements are to be shown as well as the coupling service factor. It is to be shown in the format presented in Figure A-11.

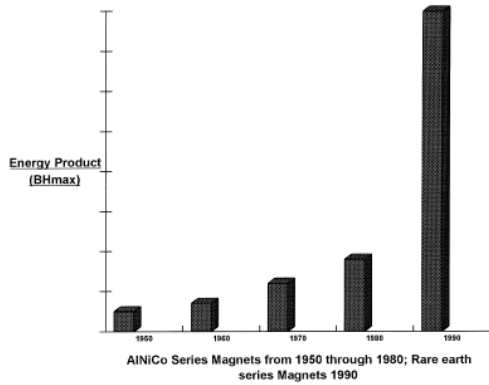

Figure A-9. Energy Product of Magnetic Materials.

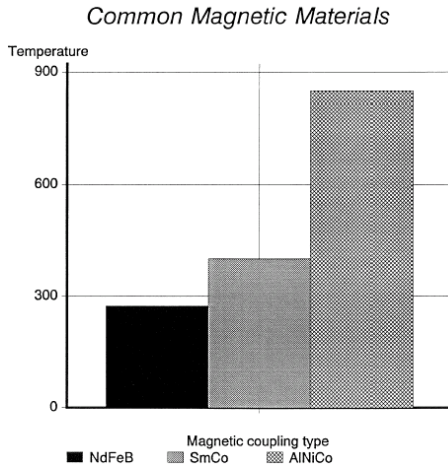

Figure A-10. Recommended Maximum Operating Temperatures ($^{\circ}$ F).

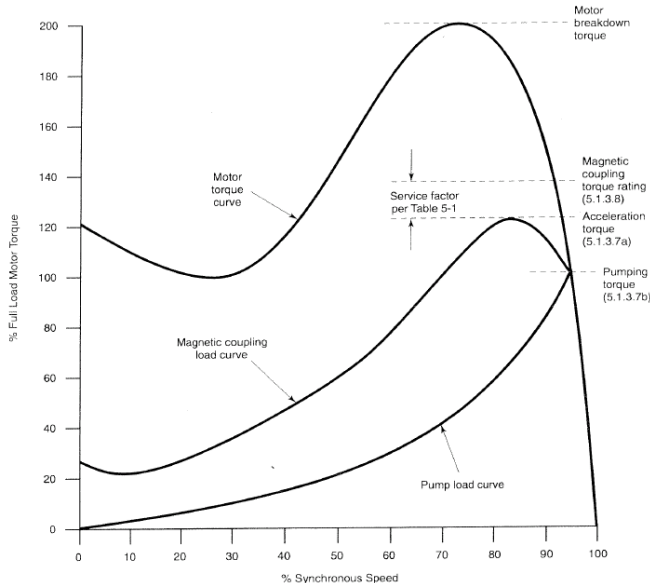

Figure A-11. Speed-Torque Curve.

Cautionary Note on Oversizing Magnetic Couplings

Hysteresis losses or “eddy currents” are generated in the metallic containment shell by the moving magnetic field of the inner and outer rotating magnets. The circulated fluid is required to remove the generated heat. An oversized coupling results in higher hysteresis losses and greater heat generation.

Eddy-current losses are very significant and are independent of the hydraulic power requirement. Hydraulic losses require correction for water tests. Therefore, it is important to understand the shop procedure for quantifying these losses prior to performance tests and for relating test conditions to guaranteed efficiencies in the specified service. The Task Force was not able to agree on an acceptable industry standard procedure (9.1.6.2).

Requirements Specifically for Canned Motor Pumps

Many of the concerns for coupled pumps can be ignored for canned motor pumps (refer to previous section, “Requirements from API 610 Applicable Only to Magnetic Drive Pumps”).

Many of the requirements for motors seen in most user specs and standards such as IEEE 841 are included in 9.2.2.

- Connection box sized at least one size larger than IEC or NEMA size for the motor used (9.2.2.4)
- Motor designed for across-the-line starting (9.2.2.5)
- Motor capable of three starts per hour from ambient (9.2.2.6)
- Insulation good for 175,000 hours at maximum temperature (9.2.2.7)
- Class F insulation minimum (9.2.2.8—this paragraph needs updating)
- Supplemental nameplate requirements (9.2.5)
- Winding resistance tests and dielectric tests of winding insulation (9.2.7)

Some “when specified” options are included because some users would not always want to pay a premium for the feature. These include:

- Design to special operating conditions such as frequent starts or multispeed operation.
- UL, FM, or equivalent certifications provided.
- Decontamination flush or purge connection on the stator assembly.

Vendor’s Data Specific to Sealless Pumps

When a coordination meeting is held, some of the topics for discussion that are unique to sealless pumps would include: (10.1.3)

- Magnetic coupling sizing (MDP only)
- Temperature-pressure profile

Also, the proposal is to include: (10.2.3)

- A description of special requirements specified in purchaser’s inquiry and outlined in 6.1.8, 6.1.11, 6.1.12, 6.4.2.3, 6.9.3.1, 6.11.2, 7.2.4.1, 7.4.1, 9.1.3.8, 9.1.4.2.2.

Otherwise, the drawing and data requirements read essentially the same as for an API 610 pump.

APPENDICES

Appendix A lists referenced publications including many ISO references. Appendix A also contains two tables of corresponding international standards but cautions that “the requirements contained in those standards may be significantly different and determining the equivalence or acceptability is the responsibility of the parties involved.”

Appendix B is the SI and US Customary data sheets created in Microsoft[®] Excel format. It follows closely the format of API 610 Data Sheets with the addition of sealless pump specifications and deletion of requirements for nonapplicable pump types.

Appendix C is the nomenclature for sealless pumps. It identifies the major parts typically used in MDP and CMP, and also shows some of the terms applicable only to the sealless designs.

Appendix D illustrates the typical auxiliary plans associated with sealless pumps. These are typically modifications of API 610, Eighth Edition, plans and use a similar numbering system. There

are plans for clean pumpage, plans for dirty or special pumpage, and plans using cooling water.

Appendix E lists and illustrates many of the instrumentation and protective systems that may be applied to sealless pumps.

Appendix F is the criteria for piping design (allowable forces and moments transmitted to the pump casing). It is a simplified version of the API 610, Eighth Edition, criteria. Only the portion applicable to overhung pumps is included.

Appendix G is the material class selection guide. It shows the minimum suggested material class for some general services. It is basically the API 610 list and should be more tailored in the future for services that are more typically an application for sealless pumps.

Appendix H is the listing of materials for specific parts applicable to the material classes. It is expanded from API 610 to include material combinations often applied in sealless applications. Additions include:

- S-9: Carbon steel casing and Monel® internals
- H-1 and H-2: Hastalloy® B and C casings and internals
- T-1: Titanium casing and internals
- A-9: Alloy 20 casing and internals

Appendix I is information on materials for magnetic couplings. It includes information on the manufacturing processes and properties for the materials noted in the standard. It should probably be updated in the next issue to reflect present technology improvements.

Appendix J is the standard API procedure for determination of residual unbalance. It should be revised in the next issue to include current corrections.

Appendix K is a further explanation and examples of how to document the pressure-temperature profile in the circulation circuit.

Appendix L is the API 610 requirement for baseplate and soleplate grouting applicable to magnet drive sealless pumps.

Appendix M is the dimensional table and illustrations of standard baseplates applicable to magnetic drive sealless pumps.

Appendix N is the inspector's checklist. The checklist suggests things that would need to be covered relative to the applicable inspection level. It is to be used as a checkoff for these requirements.

Appendix O is the detailed requirement suggested for vendor drawings and data submittal.

Appendix P is a checklist of requirements that are to be specified by the purchaser. It is suggested that it be used in conjunction with the data sheets, but in that regard is somewhat redundant. There are places on the data sheet to address all these items. Appendix P is a good quality assurance tool to assure all items have been addressed.

Appendix Q is the supplement to the API 610, Eighth Edition, standard electronic data exchange file specification. It addresses all the data sheet fields that are different to API 610, Eighth Edition. It follows the same format but uses the next sequential segment (G).

Appendix R is the standard API table of factors to convert metric to US units.

Appendix S was the API 610, Eighth Edition, appendix for determination of true peak vibration measurements. It was withdrawn in final editing consistent to the suggestion of the API 610, Ninth Edition, Task Force.

Appendix T contains the API 610, Eighth Edition, forms for documentation of pump testing as modified for sealless specific requirements.

Appendix U is somewhat unique in that it contains application information for sealless pumps. This was offered because sealless technology was very new for much of the hydrocarbon industry and it was known that many users had been soured by early failures caused by misapplication of the technology.

FUTURE OF API 685

API reports that to date there have been roughly 125 copies sold plus another couple of dozen given to task force members, steering committee members, etc. While not insignificant, this is still far below the thousands sold for the more popular standards such as API 610 (1995) and API 611 (1997). There continues to be strong interest from European concerns while the US market has lagged behind. At present only a couple of US companies are heavily promoting API 685 designs. Most of the US installations for sealless pumps have involved chemical duty applications, but there are a few notable exceptions (Figure A-12).



Figure A-12. API 685 MDP Installation.

And stories of successes involving long mean time between failures (MTBFs) and the ease of installation especially for canned motor pumps have some users thinking about API 685 sealless pumps from a life-cycle cost perspective. Now that the industry has a tool for specifying a reliable heavy-duty product for those difficult services, we expect to see the number of installations multiply.

While there are a few upgrades that we have pointed out that could be done, the basic document is ISO formatted and will probably just be reaffirmed by the API Subcommittee on Mechanical Equipment. The Task Force may issue an addendum with corrections. More application base is needed before there is justification for integration into API 610, Tenth Edition, but that always remains a possibility. What the Task Force really needs is more input from the user community.

APPENDIX B— DATA SHEETS

Copies of “API 685 Sealless Centrifugal Pump Data Sheet US Customary Units” follow.

**API 685 SEALLESS
CENTRIFUGAL PUMP
DATA SHEET
US CUSTOMARY UNITS**

JOB NO. _____ PAGE _____ OF _____
 REQ / SPEC NO. _____ ITEM NO. _____ / _____
 PURCH ORDER NO. _____ DATE _____
 INQUIRY NO. _____ BY _____
 REVISION _____ DATE _____

QA INSPECTION AND TEST				<input type="checkbox"/> WEIGHTS			
<input type="checkbox"/> 1	REVIEW VENDORS QA PROGRAM (8.1.1)						
<input type="checkbox"/> 2	PERFORMANCE CURVE APPROVAL						
<input type="checkbox"/> 3	SIOP INSPECTION (8.1.4)						
	TEST	NON/UT	WIT	OBS			
<input type="checkbox"/> 4	HYDROSTATIC (8.3.2)	<input type="checkbox"/>	<input type="checkbox"/>	<input type="checkbox"/>			
<input type="checkbox"/> 5	PERFORMANCE (8.3.3)	<input type="checkbox"/>	<input type="checkbox"/>	<input type="checkbox"/>			
<input type="checkbox"/> 6	NPSH (8.3.4.1)	<input type="checkbox"/>	<input type="checkbox"/>	<input type="checkbox"/>			
<input type="checkbox"/> 7	COMPLETE UNIT TEST (8.3.4.2)	<input type="checkbox"/>	<input type="checkbox"/>	<input type="checkbox"/>			
<input type="checkbox"/> 8	SOUND LEVEL TEST (8.3.4.3)	<input type="checkbox"/>	<input type="checkbox"/>	<input type="checkbox"/>			
<input type="checkbox"/> 9	SECONDARY CONTAMINANT	<input type="checkbox"/>	<input type="checkbox"/>	<input type="checkbox"/>			
<input type="checkbox"/> 10	SYSTEM HYDROTEST (8.3.4.5)	<input type="checkbox"/>	<input type="checkbox"/>	<input type="checkbox"/>			
<input type="checkbox"/> 11	CLEANLINESS PRIOR TO FINAL ASSEMBLY (8.2.3.1)	<input type="checkbox"/>	<input type="checkbox"/>	<input type="checkbox"/>			
<input type="checkbox"/> 12	NOZZLE LOAD TEST (7.3.6)	<input type="checkbox"/>	<input type="checkbox"/>	<input type="checkbox"/>			
<input type="checkbox"/> 13	SECONDARY CONTAMINANT	<input type="checkbox"/>	<input type="checkbox"/>	<input type="checkbox"/>			
<input type="checkbox"/> 14	CONTINUOUS STEAM TEST (8.3.4.9)	<input type="checkbox"/>	<input type="checkbox"/>	<input type="checkbox"/>			
<input type="checkbox"/> 15	REPAIRS AFTER TEST (8.2.8.5)	<input type="checkbox"/>	<input type="checkbox"/>	<input type="checkbox"/>			
<input type="checkbox"/> 16	DISASSEMBLY / INSPECT AFTER TEST (8.4.3.1)	<input type="checkbox"/>	<input type="checkbox"/>	<input type="checkbox"/>			
<input type="checkbox"/> 17	AUXILIARY EQUIPMENT TEST (8.3.4.4)	<input type="checkbox"/>	<input type="checkbox"/>	<input type="checkbox"/>			
<input type="checkbox"/> 18	PRESS. TEMP PROFILE TEST (8.4.7)	<input type="checkbox"/>	<input type="checkbox"/>	<input type="checkbox"/>			
<input type="checkbox"/> 19		<input type="checkbox"/>	<input type="checkbox"/>	<input type="checkbox"/>			
<input type="checkbox"/> 20		<input type="checkbox"/>	<input type="checkbox"/>	<input type="checkbox"/>			
<input type="checkbox"/> 21		<input type="checkbox"/>	<input type="checkbox"/>	<input type="checkbox"/>			
<input type="checkbox"/> 22	MATERIAL CERTIFICATION REQUIRED (8.11.6)						
<input type="checkbox"/> 23	CASING <input type="checkbox"/> IMPELLER <input type="checkbox"/> SHAFT						
<input type="checkbox"/> 24	IMPELLER						
<input type="checkbox"/> 25	CASTING REPAIR PROCEDURE APPROVAL REQ'D (8.11.2.5)						
<input type="checkbox"/> 26	INSPECTION REQUIRED FOR CONNECTION WELDS (8.11.3.5.0)						
<input type="checkbox"/> 27	MAG PARTICLE <input type="checkbox"/> LIQUID PENETRANT						
<input type="checkbox"/> 28	RADIOGRAPHIC <input type="checkbox"/> ULTRASONIC						
<input type="checkbox"/> 29	INSPECTION REQUIRED FOR CASTINGS (8.2.1.3)						
<input type="checkbox"/> 30	MAG PARTICLE <input type="checkbox"/> LIQUID PENETRANT						
<input type="checkbox"/> 31	RADIOGRAPHIC <input type="checkbox"/> ULTRASONIC						
<input type="checkbox"/> 32	ALTERNATE ACCEPTANCE CRITERIA (SEE REMARKS) (8.2.2.1)						
<input type="checkbox"/> 33	HARDNESS TEST REQUIRED FOR (8.2.3.2)						
<input type="checkbox"/> 34							
<input type="checkbox"/> 35	VITTING AGENT HYDROTEST (8.3.2.5)						
<input type="checkbox"/> 36	VENDOR SUBMIT TEST PROCEDURES (8.3.1.2/10.2.5)						
<input type="checkbox"/> 37	RECORD FINAL ASSEMBLY RUNNING CLEARANCES						
<input type="checkbox"/> 38	INSPECTION CHECKLIST (APPENDIX N) (8.1.6)						
<input type="checkbox"/> 39	SUBMIT DATA FOR MODAL STATIC TORQUE TEST (9.5.5.1)						
<input type="checkbox"/> 40	FOR SPECIFIC STATIC TORQUE TEST REQUIRED (8.1.6.1)						
<input type="checkbox"/> 41	REMARKS						

06/00 SHT 5 OF 5 685DUSUS.XLS REV 1

REFERENCES

- 1990 Clean Air Act, 1990, United States Environmental Protection Agency, Washington, D.C.
- API Standard 610, 1995, "Centrifugal Pumps for Petroleum, Heavy Duty Chemical and Gas Industry Services," Eighth Edition, American Petroleum Institute, Washington, D.C.
- API Standard 611, 1997, "General-Purpose Steam Turbines for Petroleum, Chemical, and Gas Industry Services," Fourth Edition, American Petroleum Institute, Washington, D.C.

- API Standard 682, 2002, "Pumps—Shaft Sealing Systems for Centrifugal and Rotary Pumps," Second Edition, American Petroleum Institute, Washington, D.C.
- API Standard 685, 2000, "Sealless Centrifugal Pumps for Petroleum, Heavy Duty Chemical, and Gas Industry Services," First Edition, American Petroleum Institute, Washington, D.C.
- API Standards may be obtained by calling API Publications and Distribution (202-682-8375).

