

PINION SHAFT ASSEMBLY

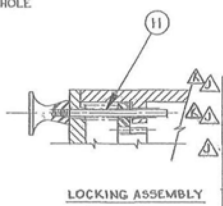

LOCKING ASSEMBLY

NOTE:  
BILL OF MATERIALS CONTINUED ON SHEET 2.

ITEM	QTY	PART NUMBER	DESCRIPTION	EST. WT.	DRAWING NO.
1	1	574591	MOTOR, 1/2 HP, 230V, 1 PH, 50HZ, 1500 RPM, F0 P.C., FR4B PAINTED		A-519380
1	1	574590	MOTOR, 1/2 HP, 115V, 1 PH, 50HZ, 1500 RPM, F0 P.C., FR4B PAINTED		A-519380
1	1	574589	MOTOR, 1/2 HP, 115V, 1 PH, 60HZ, 1800 RPM, TEFC, FR4B PAINTED		A-519380
1	1	53	500363	KIT, TACHOMETER	B-23015
1	1	52	105619	LABEL, WARNING	B-17315
1	1	51	508203	NAMEPLATE	A-14990
1	4	50	522884	SCREW, DRIVE #2 X 1/4 LG 18-8SS	
1	8	49	533372	SCREW, SHC #10-24 UNC X 1/2 LG CHR PL	
1	1	48	523451	PIN, SPRING 1/2 X 3/4 LG	
1	1	47	500349	KNOB, ADJ. 3/8 BORE CHR PL	A-500369
1	1	46	522997	WASHER, 1/2 PLAIN 316 S5T	
1	1	45	523614	NUT, ACORN 1/2-13 UNC CHR PL	
4	4	44	101610	SCREW, SHC #10-24 UNC X 1/2 LG CHR PL	
4	4	43	522962	WASHER, 5/16	
4	4	42	522280	SCREW, SHC #10-24 UNC X 1/2 LG GR5	
2	2	41	523081	SCREW, SHS #10-24 UNC X 3/16	
1	1	40	523084	SCREW, SHS 3/8-16 UNC X 1/2 LG CUP PL	
1	1	39	500382	WASHER, DRIVE GUARD	A-15714
1	1	38	522457	NUT, HEX 1/2-13 UNC	
4	4	37	522928	LOCKWASHER, SPRING 1/2	
4	4	36	522192	SCREW, HHC 1/2-13 UNC X 1/2 LG GR5	
4	4	35	522841	NUT, JAM 3/8-16 UNC	
4	4	34	523791	BOLT, ELEVATOR 3/8-16 UNC X 3/4	
1	1	33	529642	PETCOCK	A529642
1	1	32	521544	PLUG, PIPE CSK 1/2 NPT	
3	3	31	520927	SEAL, OIL	A520857
2	2	30	524463	CUP, BEARING	A524663
2	2	29	524415	CONE, BEARING	A524615
1	1	28	500352	STUD, DRIVE GUARD	A-8842
1	1	27	101565	SHIM, .020	A-101565
1	1	26	101564	SHIM, .010	A-101564
1	1	25	101563	SHIM, .005	A-101563
1	1	24	101562	SHIM, .003	A-101562
1	1	23	500372	PAD, TANK BASE	G-2035
1	1	22	500357	LOCKNUT, CONTROL	A-10314
1	1	21	500351	BAR, ADJUSTABLE CONTROL	A-8863
1	1	20	532994	PLATE, MOTOR	B51302
1	1	19	532995	CAP, SPINDLE BEARING	A-8875
1	1	18	500390	HOOD	B-17649
1	1	17	200560	IMPELLER, OPEN	B-18945
1	1	16	500350	STANDPIPE	B-7930
1	1	15	532993	GUARD, DRIVE	C-56641
1	1	14	532996	HOUSING, SPINDLE BEARING	B-7329
1	1	13	532998	SUPPORT, SPINDLE BEARING	F-4408
1	1	12	500318	BASE	C-1873
1	1	11	500360	ASSY, PINION LOCKING SHAFT	A-8868
1	1	10	500362	ASSY, PINION SHAFT	B-16424
1	1	9	500247	ASSY, SUPPORTING SHAFT	A-9022
1	1	8	500393	SHAFT, IMPELLER	A-9023
		7			
		6			
		5			
1	1	4	520359	V-BELT	
1	1	3	519802	SHEAVE, 3 3/8 O.D.	
1	1	2	519823	SHEAVE, 4" O.D.	
1	1	1	519380	MOTOR, 1/2 HP, 115 V, 1 PH, 60 HZ, 1800 RPM, TEFC, FR4B PAINTED	A519380

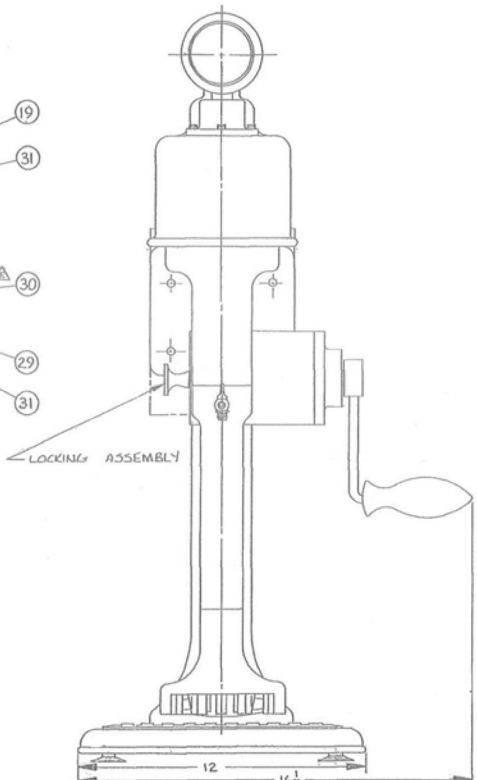

LOCKING ASSEMBLY

REV	CHANGE DESCRIPTION	CHK	BY	DATE	APPRO	REV	CHANGE DESCRIPTION	CHK	BY	DATE	APPRO
L	ITEM 20 WAS ADJUST	54338	JF	2/24/84		DELETED ITEMS 5, 6, 7	26700	JR	2/24/84		
K	50 Hk Motor's Name 1800 RPM	32704	MP	2/24/84		15 WAS C12E, A2 WAS	25814	DL	2/24/84		
J	TABBED FOR OTHER MOTOR		MP	2/24/84		522176, REVISED BY MP					
H	TABBED FOR 1/2 HP MOTOR		MP	2/24/84		D REDRAWN & RESTRICTED	22220	DR	2/24/84		
G	WAS 1/2 HP, TENV, MTR	30961	MP	2/24/84							

ITEM 53 WAS PH. 221145 STOSS IN HANDBOOK

UNLESS OTHERWISE SPECIFIED TOLERANCES TO BE FRACTIONAL, A .015" ON A .0625" PER FOOT OF LENGTH, DIMENSIONS IN SQUARE BRACKETS ARE IN DECIMALS OF AN INCH, ALL DIMENSIONS UNLESS OTHERWISE SPECIFIED ARE SHOWN EDGES AND CORNERS .015" MAX.

THIS DRAWING AND ALL INFORMATION HEREON IS THE PROPERTY OF SVEDALA PUMPS & PROCESS. IT IS TO BE KEPT IN CONFIDENCE AND NOT TO BE MADE PUBLIC, COPIED OR USED IN ANY WAY DETRIMENTAL TO OUR INTEREST. IT IS LOANED SUBJECT TO RETURN ON DEMAND, UNLESS FURNISHED UNDER CONTRACT PROVISIONS.

MACHINE ASSEMBLY  
MODEL D-12  
LAB. FLOTATION MACH.

SVEDALA PUMPS & PROCESS  
SVEDALA INDUSTRIES, INC.  
D-28179

SHEET 1 OF 2

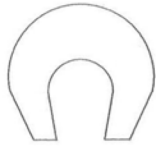

ITEM 66  
SCALE: 2"=1"

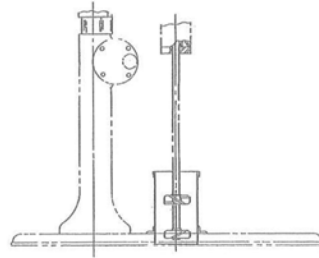

ITEM 68

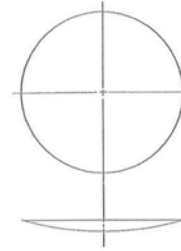

ITEM 65  
SCALE: 1/4"=1"

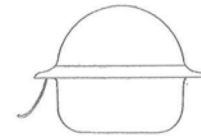

ITEM 67  
SCALE: 1"=1"

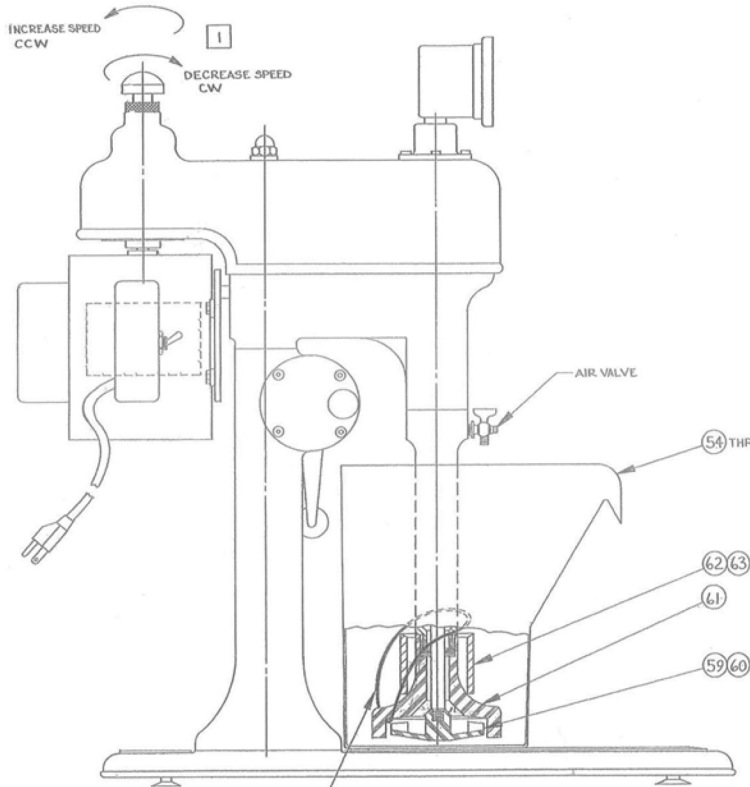

LOCKING ASSEMBLY

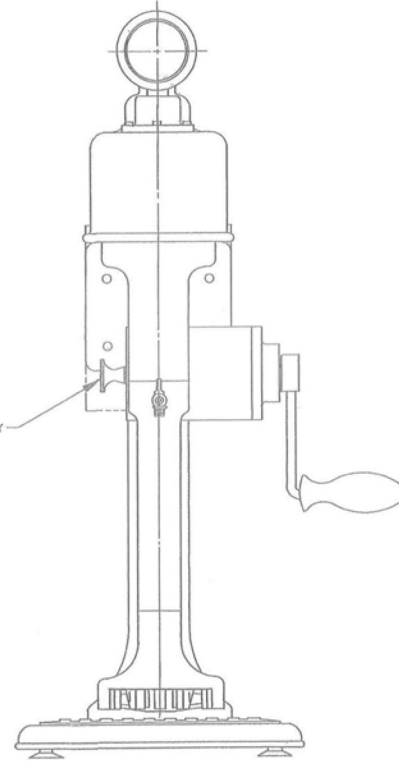

- NOTES:  
 1 ADJUST SPEED ONLY WHEN MOTOR IS RUNNING.  
 2 APPROXIMATE MACHINE WEIGHT : 200 LBS

QTY	ITEM	DESCRIPTION	EST. WT.	DRAWING NO.
1	68	500364 KIT, AGITATOR & ATTRITION SCRUBBING		C-24500
1	67	507410 TESTER, HYDRION(LITMUS PAPER)		
1	66	507394 MAGNET		A-4699
1	65	507396 PLAQUE, VANNING 10 DIA		A-8764
3	64	100336 BAND, RUBBER 1/8 X 3 1/2 LG		
1	63	500388 FLUIDIZER		A-13905
1	62	500327 FLUIDIZER		A-10925
1	61	500333 HOOD		B-17658
1	60	200563 IMPELLER, OPEN		B-38944
1	59	201588 IMPELLER, CLOSED		B-18936
1	58	500402 TANK, 2000 GRAM 304 SST		F-4610
1	57	500399 TANK, 1000 GRAM ACRYLIC		F-12826
1	56	500400 TANK, 1000 GRAM 304 SST		G-2003
1	55	500380 TANK, 500 GRAM 304 SST		F-4150
1	54	500378 TANK, 280 GRAM 304 SST		F-4149

QTY	ITEM	DESCRIPTION	EST. WT.	DRAWING NO.
TOTAL EST. WEIGHT				
UNLESS OTHERWISE SPECIFIED TOLERANCES TO BE: FRACTIONS, ± 1/64" OR ± 1/64" PER FOOT OF LENGTH; DIMENSIONS IN PARENTHESES, XX ± 0.0002; ANGLES, ± 1°; ALL MACHINED SURFACES TO BE BRASS. ALL GRAMP EDGES AND CORNERS R0.5 MAX.				
THIS PRINT AND ALL INFORMATION HEREON IS THE PROPERTY OF SVEDALA INDUSTRIES, INC. AND SHALL NOT BE MADE PUBLIC, COPIED OR USED IN ANY MANNER WITHOUT THE WRITTEN CONSENT OF SVEDALA INDUSTRIES, INC. UNLESS OTHERWISE SPECIFIED IN A CONTRACT.				

SCALE 3/8"=1"				DATE 8-11-81	
DRW. D. J. ROSS				APP'D. 8-18-81	
CHG'D. 15 TIME				APP'D.	
SEE SHEET 1					
INITIAL DRAWING RELEASE					
REV	CHANGE DESCRIPTION	CHK	BY	DATE	APP'D.

MACHINE ASSEMBLY  
MODEL D-12  
LAB. FLOTATION MACH.

SVEDALA INDUSTRIES, INC.  
P.O. BOX 100  
LAB. FLOTATION MACH.  
D-28179