

# The ABC's of

# Synchronous Motors

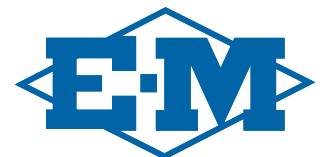

WEG Group

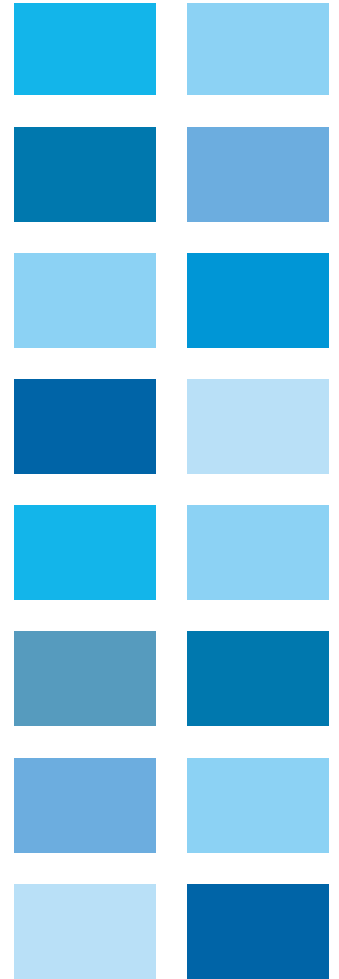

## The ABC's of Synchronous Motors

The Greeks had a word for it —SYNCHRONOUS — "syn" a prefix meaning "with," and "chronos" a word denoting time. A synchronous motor literally operates "in time with" or "in sync with" the power supply.

The modern synchronous motor is a double-duty motor. It is a highly efficient means of converting alternating current electrical energy into mechanical power. Also it can operate at either leading, unity, or in rare cases at lagging power factor, providing the function of a synchronous condenser for power factor correction.

In the synchronous motor, the basic magnetic field is obtained by direct current excitation rather than through the air-gap from the armature, as is the case with induction motors. Comparatively large air-gaps are used, making practicable the manufacture, even in relatively low horsepower ratings of low speed synchronous motors. In all low speed ratings and in large high speed ratings, synchronous motors are physically smaller and less costly to build than squirrel-cage induction motors of equivalent horsepower.

A synchronous motor can be applied to any load which can be successfully driven by a NEMA Design B squirrel-cage motor. However, there are certain types of loads for which the synchronous motor is especially well suited. The correct application of synchronous motors results in substantial savings in several ways:



*Synchronous motor 24800 HP at 225 RPM with TEWAC enclosure driving a reciprocating compressor at a polyethylene plant.*



# The ABC's of Synchronous Motors

## 1. High efficiency

Synchronous motors have a unique and merited position as the most efficient electrical drive in industry. They perform with great economy while converting electrical power to mechanical power and can be built with unique physical features. Synchronous motors can be designed to effectively operate over a wide range of speeds to provide the best drive for a wide variety of loads.

## 2. Power factor correction

Because they can operate at leading power factors, synchronous motors can help reduce your power costs and improve efficiency of the power system by correcting low power factor. In a few years, savings in power bills may equal the original investment in the motor.

## 3. Reduced maintenance

Synchronous motors with brushless exciters practically eliminate the need for motor maintenance other than routine inspection and cleaning.

## 4. Space savings

Engine-type synchronous motors can be connected directly to the shaft and bearings of the driven equipment. This approach saves on floor space, extra building costs, and makes for a simple installation.

## 5. Constant speed means better quality products

Synchronous motor speed is unaffected by line or load conditions. In certain applications, e.g. paper mill pulp machines, constant speed operation results in superior uniformity and quality of the product being produced.

## 6. Adjustable speed means lower power costs

In many cases it is much more economical to operate driven equipment at reduced speeds. This can be accomplished using synchronous motors in conjunction with magnetic drives, or through electronic methods, which can be used to supply an adjustable frequency to the machine and control its operating speed. Typical applications for adjustable speeds include pumps and fans. Either approach can reduce power costs and provide a more cost-effective process.



## The ABC's of Synchronous Motors

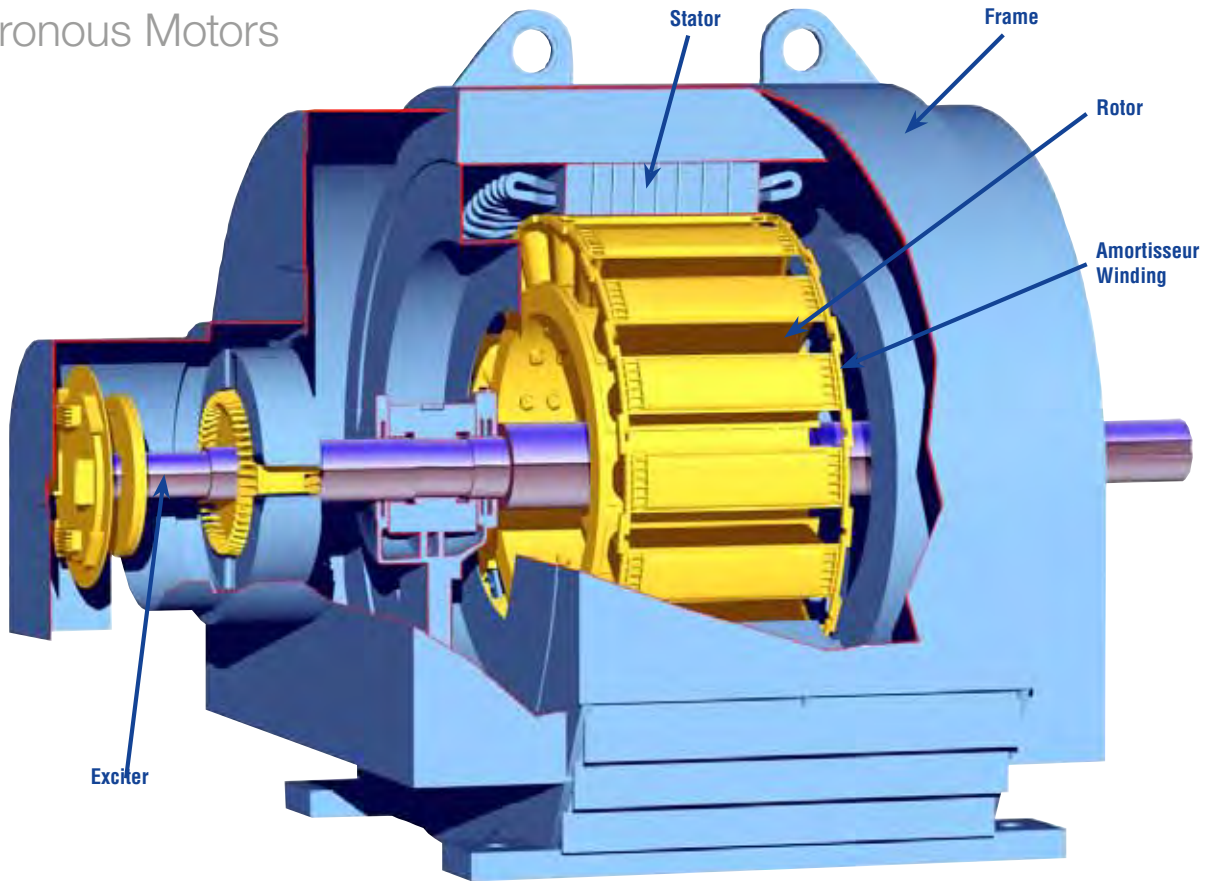

### EM synchronous motors are designed and built to industry standards

ANSI, IEC, IEEE and NEMA standards help both manufacturer and user by providing definitions and suggested values. They are continually updated to incorporate the latest trends in machine use. Although these standards are gradually coming closer together, this is a long process. ANSI and/or NEMA provide the standards for synchronous motors in the United States, whereas IEC standards provide the guidelines for European applications. Standards are a great help in understanding the application of motors. Please refer to NEMA MG1 part 21, Synchronous Motors, or ANSI C50.

### The parts of a synchronous motor

**FRAME ...** supports and protects the motor; it is built in horizontal and vertical types and in various protective constructions for indoor or outdoor service.

**STATOR ...** consists of the stationary magnetic parts, including the core and winding which operate off the alternating current power supply to provide a rotating magnetic field.

**ROTOR ...** consists of the rotating active parts, and includes the spider, the field-pole winding and the amortisseur winding. Field poles are magnetized by direct current from the exciter or directly through collector rings and brushes; they interlock magnetically through the air-gap and revolve in synchronism with the rotating magnetic poles of the stator.

**EXCITER ...** supplies magnetizing current to the field winding. Modern exciters are of the rotating brushless type with no collector rings or brushes.

**AMORTISSEUR WINDING ...** makes a synchronous motor self-starting like a squirrel-cage induction motor. Depending on the type of loads and the torque required, a variety of bar materials and arrangements can be used to provide adequate starting torque.



## The ABC's of Synchronous Motors Geared

*Synchronous motors are "geared" to the power supply*

During operation, the stator of a polyphase alternating current motor has a rotating magnetic field. This is developed by the direction and amount of current flow in the stator coils.

Figure 1 represents a two-pole, three-phase stator, having one slot per pole per phase in which there are six stator coils. These coils are connected to a three - phase power supply having phase rotation A, B, C.

At the instant shown, the current in phase A in maximum positive enters the motor at A+ and leaves at neutral where the three conductors meet. The "A" arrows in Figure 1 represent the magnetic flux (lines of force) developed by this current. At this instant the current in phases B and C is negative, each equal to one-half the current in A. The magnetic flux developed by B is shown by the "B" arrows, each equal to half the "A" arrows. The flux developed by C is represented by the "C" arrow, each equal to half of A. B and C also have horizontal components but, as shown, they cancel out.

The result is a vertically polarized stator, with a North pole at the top and a South pole at the bottom. The arrows show the flux flowing downward through the rotor.

One-twelfth revolution later (Figure 2), the positive current in A has dropped in value and is equal to the negative value in C, which has increased in value. The current in B is zero. Equal field strengths are developed by A and C and, canceling out the opposing components, we find the total flux in Figure 2a to be represented by the two "A" and two "C" arrows, 30° from the former position.

At the 60° position, shown in Figure 3, the current in phase B and the corresponding stator coils are positive and equal to phase A. The current in phase C is maximum negative. After canceling out the opposing components, we find a resultant field, as shown in Figure 3a composed principally of current in phase C, supplemented by smaller equal amounts in phases A and B.

Figures 4 and 4a complete a one-quarter turn or 90° of a two-pole motor. Continuation of this completes one revolution.

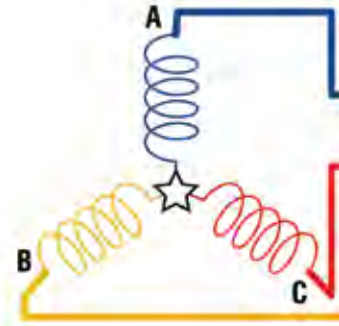

The rotor shown in the above figures is that of a two-pole synchronous motor having definite North and South poles developed by direct current flowing in the field winding. The current flows from the observer in the left hand portion of the winding, towards the observer in the right hand portion. Using the "right-hand rule" this develops a North pole at the bottom of the rotor and a South pole at the top.

The magnetic poles developed in the stator are exactly opposite. However, unlike poles attract, so the North pole of the rotor lines up under the South pole of the stator.

As the North pole of the stator shifts 30° clockwise, the rotor is pulled along with it, and (assuming no lead on the rotor shaft and no losses) the rotor and stator poles line up exactly as shown. Each rotor pole lags behind its corresponding stator pole by 20 to 30 electrical degrees at full load. This is called the "load angle," and it is a function of motor load, where increased torque requirements result in greater magnetic pull and a greater displacement from magnetic center.

A normal two pole stator differs in many respects from that shown in Figures 1 through 4. Instead of one slot per phase there are six or seven. The coil pitch is about 120° instead of 60° and will overlap the coils of the various phases. The configuration shown results in rotation by a series of jerks. The use of more closely spaced coils will result in a smoother, more uniform turning action.

**Figures 1 through 4** AC Generator; Three-phase power supply for synchronous motor. Generator voltage is assumed equal and in phase with the current; there is no load torque for friction so rotor and stator poles are free to line up magnetically.



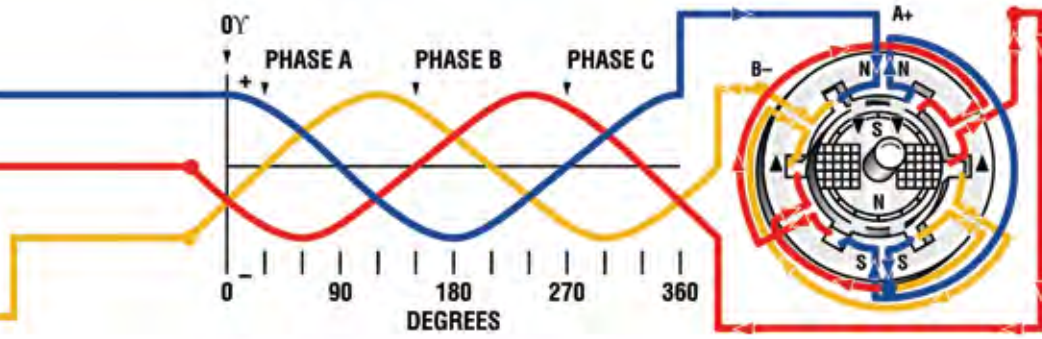

Figure 1 Current relationship, and magnetic resultant (Figure 1a) of a two-pole synchronous motor with rotating magnetic field at 0°.

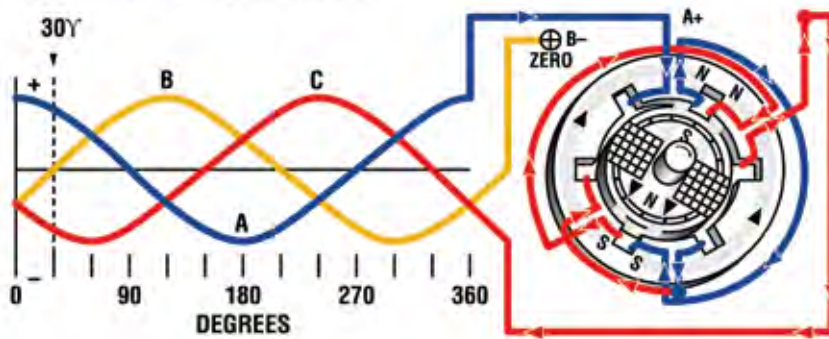

Figure 2 Current relationship, and magnetic resultant (Figure 2a) of a two-pole synchronous motor with rotating magnetic field at 30°.

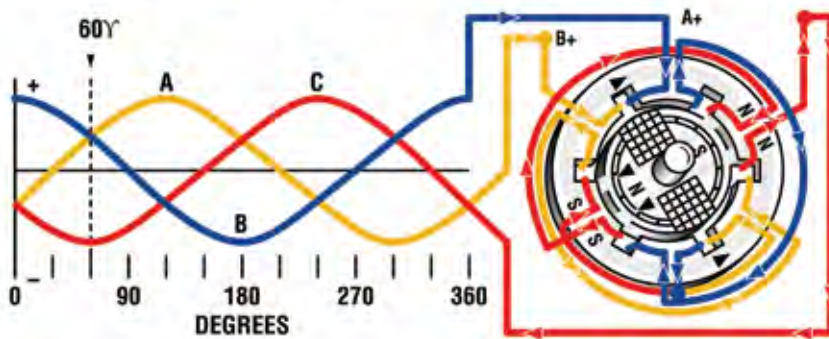
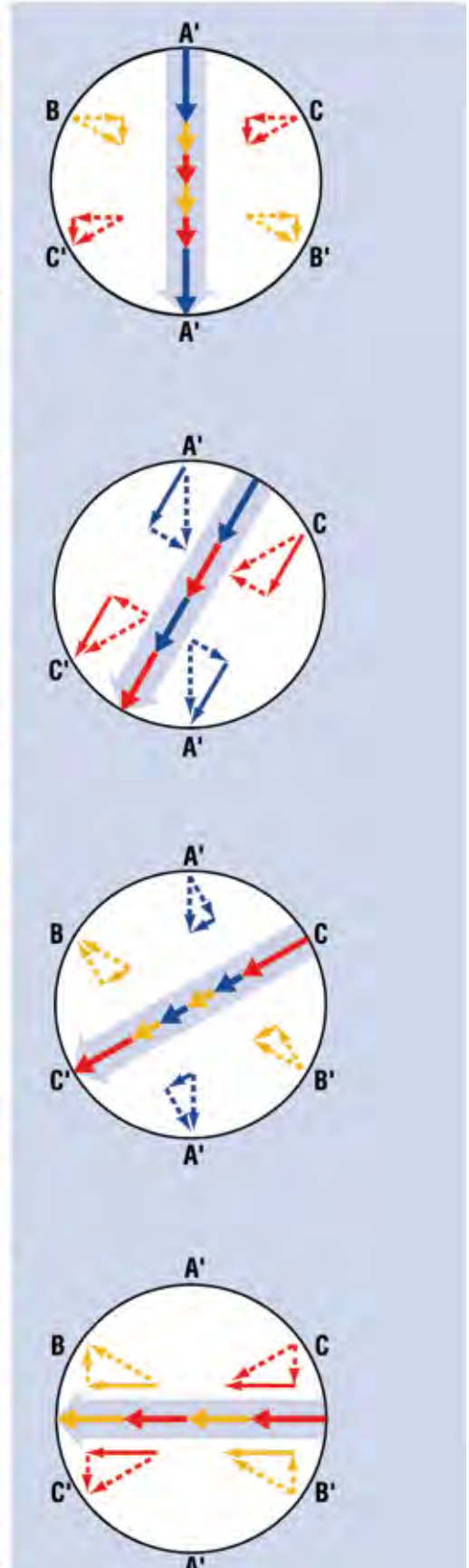
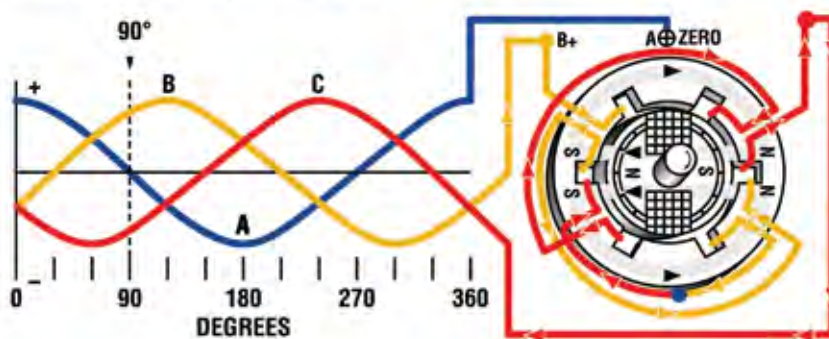

Figure 3 Current relationship, and magnetic resultant (Figure 3a) of a two-pole synchronous motor with rotating magnetic field at 60°.



# The ABC's of Synchronous Motors

## Power Factor

### *How synchronous motors control power factor*

Power factor is the factor by which apparent power, or kVA, is multiplied to obtain actual power, or kW, in an ac system. It is the ratio of the in-phase component of current to total current. It is also the cosine of the angle by which the current lags (or leads) the voltage.

The conversion of electrical energy to mechanical energy in a motor is accomplished by magnetic fields. In the previous section, it was explained how magnetic poles are formed when current flows in coils placed around the stator gap bore. As explained, these poles rotate around the stator. When voltage is applied to a motor, an armature current flows to provide the necessary magnetic push (mmf or ampere turns) to produce a flux which, in turn, produces a voltage (back emf) that opposes the applied voltage. This mmf is a magnetizing current. It is loss-less, except for the  $i^2r$  in the winding and any core loss due to the changing flux in the iron. The magnetic energy is transferred from the line to the motor and back again each half cycle. The net power is zero, and the power factor is zero.

The power factor of a synchronous motor is controllable within its design and load limits. It may operate at unity, leading, or in rare cases, lagging power factor and may be used to modify the power factor of the system to which it is connected. A simplified explanation of phasor relationships will describe what takes place under various load and excitation conditions.

Phasors are vectors that represent the relationship between voltages or currents. The phasor length represents the magnitude and, as it is allowed to rotate counterclockwise about the origin, the projection on the x axis is the instantaneous value.

Figures 5, 6 and 7 show the instantaneous voltage, current and power (V times I) for unity, leading and lagging power factors. The magnitude of the current and voltages is held constant for all cases. Also shown is the corresponding phasor diagram for each in Figure 5a, 6a and 7a. Note that for lagging power factor, the current phasor lags the voltage phasor and the instantaneous current passes through zero after the voltage.

The power for unity power factor is always positive while both leading and lagging power factors have some negative power values, and the peak is less than for unity. Thus, the average value of power is less for either leading or lagging power factor for the same current and voltage.

Once the synchronous motor is synchronized, the field poles on the rotor are in line with the rotating magnetic poles of the stator. If dc is applied to the rotor pole windings, the rotor can supply the necessary ampere turns to generate the flux which produces the internal motor voltage. Thus, the field current can replace part or all of the magnetizing current. In fact, if more dc field current is supplied, the increased flux will try to increase the line voltage. To increase the line voltage, the motor will supply ac magnetizing current to all "magnets" on the system to increase their magnetic flux. This is leading power factor.

The synchronous torque developed is roughly proportional to the angle of lag (load angle) of the motor rotor with respect to the terminal voltage, which, at full load, is in the area of 20 to 30 electrical degrees. If a restraining force is applied to the motor shaft, it will momentarily slow down until a torque is developed equal to the applied restraint. The motor will then continue to operate at synchronous speed.

Figure 8 shows a somewhat simplified phasor diagram for a unity power factor motor connected to a large system such that the terminal voltage is fixed. Since synchronous machines have poles and interpole spaces, a system of phasors represent each of the "direct" (in line with the pole) and "quadrature" axes (interpole).

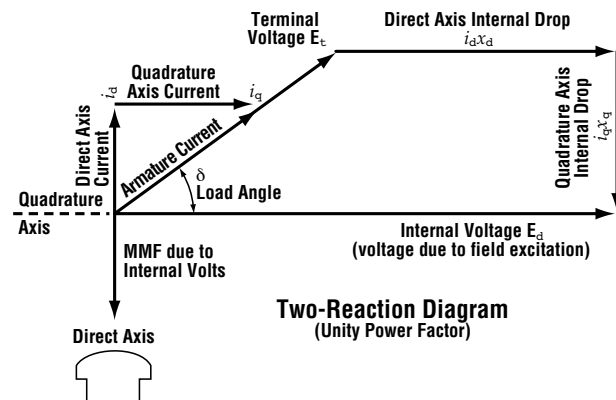

**Figure 8**

# The ABC's of Synchronous Motors

## Power Factor

In drawing the diagram, the reactance drop is subtracted from the terminal voltage to obtain the internal voltage and the direction of the quadrature and direct axes. The internal voltage sets the level of flux in the motor, which, in turn, sets the mmf required (ampere-turns or magnetizing current). The current flowing in the armature winding produces an mmf called armature reaction. The portion, in line with the direct axis, must be added (or subtracted, for lagging P.F.) to the mmf, producing the internal voltage. Since the field winding on the rotor poles is in line with the direct axis, dc in this winding can supply the required mmf.

If the dc is increased, the internal voltage will increase, and since the terminal voltage is fixed by the connected system, the internal drop must increase. The result of this is shown in Figure 9 where the line current is increased and repositioned to a leading power factor.

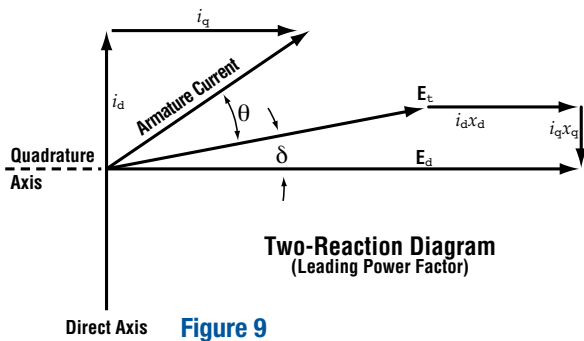

Note that the current in phase with the voltage represents the load and is unchanged, but a magnetizing component has been added. This component flows to the line to try to raise the system voltage. The motor has a leading power factor.

If, instead, the dc is decreased, the internal voltage will try to reduce the system voltage, resulting in a magnetizing current drawn from the system. The motor then has a lagging power factor.

The fact that the field poles of a synchronous motor are magnetically in line with the stator flux allows dc current on the field to replace ac magnetizing current on the stator. Since power factor is determined by the magnetizing current, the power factor is adjustable by changing the field current.

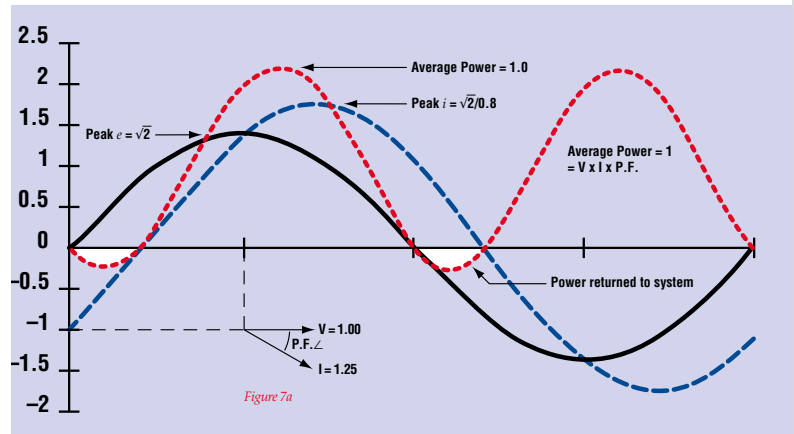
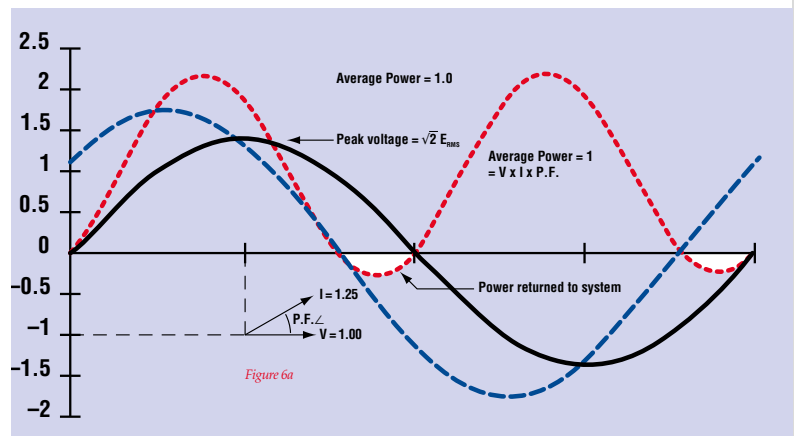
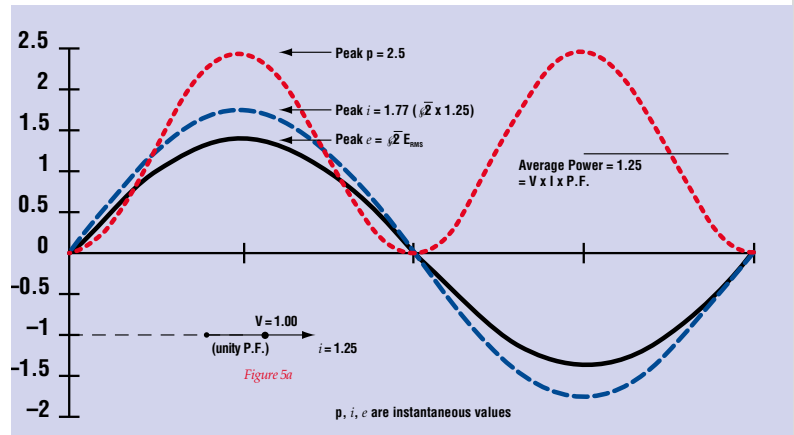

**Figure 5 (top)** 0.8 P.F. Motor at unity P.F.  
**Figure 6 (middle)** 0.8 P.F. Leading.  
**Figure 7 (bottom)** 0.8 P.F. Lagging.

P.F. ∠ stands for Power Factor Angle.





# The ABC's of Synchronous Motors

## Power Factor

**Figure 10**

For any given load, the power factor at some given excitation value will be the ratio of minimum line amperes at that load, to the line amperes at the excitation value under consideration. Assume a steady load condition in which the line amperes, at various excitation values, lie along line A-O-B; with point O representing minimum ac input and point B representing the input at the desired excitation value. The power factor at that excitation is  $CO \div DB$ .

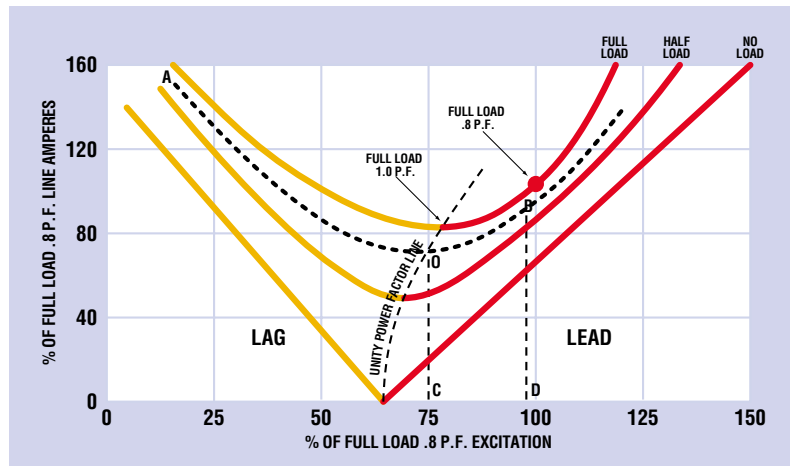

**Figure 11**

Plant loading and power factor.

Plant Loading and Power Factor (induction motor proposed)

Load	Monthly Averages			Calculated		Transformer		
	MWH	P.F.	Hrs (Est)	kW	kVAR	kVA	Load	Rating
T1 Office	77	0.92	194	400	-170	435	435	T1=1000
T2 Pumps	587	0.72	335	1750	-1687	2431	2431	T2=2000
T3 Air	235	0.82	335	700	-489	854	854	T3=1500
T4 Mill	1347	0.88	464	2900	-1565	3295	-	-
T4 Proposed	335	0.81	335	1000	-724	1235	4522	T4=4000
Overall	-	0.824	-	6750	-4635	8188	-	-

### “V” Curves

It is generally assumed that the line voltage will be substantially constant, and it is apparent from the preceding discussion that load, excitation, line amperes, and power factor are closely related. This relationship is readily expressed by a family of characteristic curves known from their shape as “V” curves. These are represented in Figure 10. Note that for each curve the power is constant and the excitation is varied to give different magnetizing currents.

The minimum value of line amperes for each load condition is at 1.0 or unity power factor. As excitation is decreased, the line current will increase and the motor will operate at lagging power factor. If excitation is increased from the 1.0 power factor condition, the line current will again increase, but now the motor will operate under a leading power factor condition.

For any load, the power factor will be the ratio of minimum line amperes at that load to the line amperes at the excitation value under consideration. To operate at 1.0 power factor for maximum efficiency, set the excitation for minimum ac line current.

Plant Loading and Power factor (synchronous motor proposed)

Load	Monthly Averages			Calculated		Transformer		
	MWH	P.F.	Hrs (Est)	kW	kVAR	kVA	Load	Rating
T1 Office	77	0.92	194	400	-170	435	435	T1=1000
T2 Pumps	587	0.72	335	1750	-1687	2431	2431	T2=2000
T3 Air	235	0.82	335	700	-489	854	854	T3=1500
T4 Mill	1347	0.88	464	2900	-1565	3295	-	-
T4 Proposed	335	.8	335	1000	750	1250	4522	T4=4000
Overall	-	0.906	-	6750	-3161	7453	-	-

**Figure 12**

For leading power factor synchronous motors, leading kVARs indicates kVARs fed to the system, where as induction motors always absorb kVARs from the system.

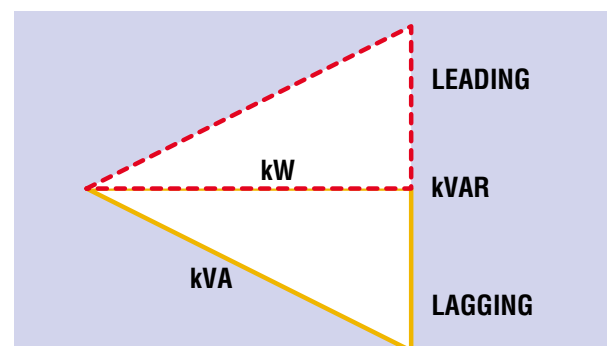



# The ABC's of Synchronous Motors

## Power Factor

### System Power Factor Correction

The power usage and the power factor of a plant should be periodically reviewed to avoid surprises. A typical plant power system is shown in the form of a spreadsheet in Figure 11. Here it is assumed that you have monthly records for the various load centers. A proposed plant expansion employing either an induction or a synchronous motor is under consideration. T1, T2, etc. represent transformers or load centers.

From the MWH and the estimated operating hours, the average kW is calculated. Next, calculate the kVAR and kVA using the power factor. Tabulation of results is shown in Figure 13.

Note that the terms “leading” and “lagging” refer to the current leading or lagging the voltage. The current to induction motors will lag, and the motor will draw magnetizing current from the system. Leading P.F. synchronous motors feed magnetizing current to the system. As shown in Figure 12, lagging currents are treated as negative, leading as positive.

$$kVAR = \sqrt{kVA^2 - kW^2}$$

$$kVAR = kW \times \tan(\theta)$$

(where  $\theta$  is the angle in degrees, by which the current differs from the voltage.)

$$kW = kWH/H$$

$$\text{Motor rated kVA} = \frac{0.746 \times HP}{\text{Eff.} \times \text{P.F.}}$$

If the proposed expansion is an induction motor, the overall power factor will be less than 0.9. This will result in additional charges by the power company. Note that transformer T4 in Figure 11 will be overloaded.

If the addition is a 0.8 leading P.F. synchronous motor, the total kW will be the same, but the kVAR will be less, and the overall power factor will be over 0.9. The overload on T4 is eliminated. In calculating the load on T4, it is necessary to first combine the kW's and kVARs separately and then calculate the kVA as the square root of the sum of the squares.

Figure 14 shows the reactive capability of typical synchronous motors. These curves plot the percent kVAR vs. percent load. To use the curve, determine the kVAR based on the percent load and rated power factor of the motor. The reactive kVAR is then the rated horsepower multiplied by the percent kVAR determined. For example, a 250 horsepower, 0.8 power factor motor operating at 100% load gives a 0.6 factor. The kVAR is then  $250 \times 0.6 = 150$  kVAR supplied to the system. Excitation is maintained at the full load value.

Power Factor	Ratio kVAR/kW	Power Factor	Ratio kVAR/kW	Power Factor	Ratio kVAR/kW
1.00	.000	.80	.750	.60	1.333
0.99	0.143	0.79	0.776	0.59	1.369
0.98	0.203	0.78	0.802	0.58	1.405
0.97	0.251	0.77	0.829	0.57	1.442
0.96	0.292	0.76	0.855	0.56	1.48
0.95	0.329	0.75	0.882	0.55	1.518
0.94	0.363	0.74	0.909	0.54	1.559
0.93	0.395	0.73	0.936	0.53	1.600
0.92	0.426	0.72	0.964	0.52	1.643
0.91	0.456	0.71	0.992	0.51	1.687
0.90	0.484	0.70	1.02	0.50	1.732
0.89	0.512	0.69	1.049	0.49	1.779
0.88	0.540	0.68	1.078	0.48	1.828
0.87	0.567	0.67	1.108	0.47	1.878
0.86	0.593	0.66	1.138	0.46	1.930
0.85	0.62	0.65	1.169	0.45	1.985
0.84	0.646	0.64	1.201	0.44	2.041
0.83	0.672	0.63	1.233	0.43	2.100
0.82	0.698	0.62	1.266	0.42	2.161
0.81	0.724	0.61	1.299	0.41	2.225

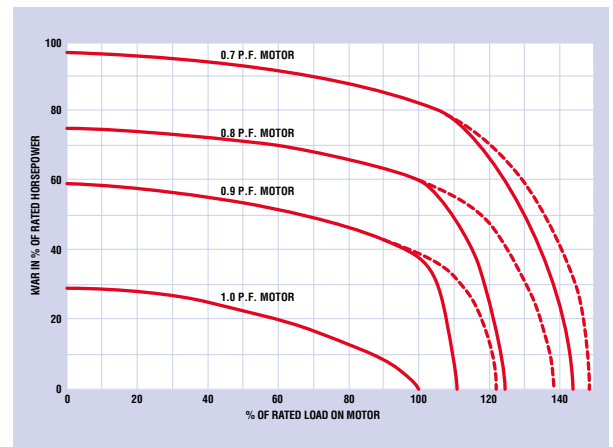

**Figure 14** Leading reactive kVA in percent of motor horsepower for synchronous motors at part load and at various power factor ratings. Solid lines are based on reduction in excitation, at overload, to maintain rated full-load amperes; dotted lines represent values with rated excitation to maintain rated pull-out torque.



# The ABC's of Synchronous Motors

## Torque

*Torque makes the wheels go 'round*

Torque may represent either the turning effort developed by a motor or the resistance to turning effort exerted by the driven load. It is defined as tangential pull at a radius of one unit from the center of rotation. In the United States it is measured in foot-pounds or inch-pounds. For a given condition:

$$\text{Torque} = \frac{\text{HP} \times 5250}{\text{rpm}}$$

- Torque = Tangential effort in pounds at one foot radius
- HP = Horsepower developed
- rpm = Revolutions per minute

In some cases motor torques are expressed in foot-pounds; however, they are usually expressed as a percentage of full load torque.

A synchronous motor has many important torques that determine the ability of the motor to start, accelerate, pull its connected load into step, and operate it through anticipated peak loads within its design limits.

These torques may be described as:

### 1. Starting torque or breakaway torque.

This is the torque developed at the instant of starting at zero speed.

### 2. Accelerating torque.

This is the motor torque developed from stand-still to pull-in speed minus the load torque.

### 3. Pull-up torque.

This is the minimum torque developed between stand-still and the pull-in.

### 4. Pull-in torque.

This is the torque developed during the transition from slip speed to synchronous speed and generally is defined at 95% speed.

### 5. Synchronous torque.

This is the steady state torque developed during operation. It is load dependent.

### 6. Pull-out torque.

This is defined as the maximum steady state torque developed by the motor, for one minute, before it pulls out of step due to overload.

## Starting and accelerating torques

The characteristics of these torques are closely allied and will be discussed together. Five individual torques contribute to the turning effort of a synchronous motor during starting and accelerating. They are produced by:

1. Amortisseur windings
2. Field windings
3. Hysteresis in pole faces
4. Eddy currents in pole faces
5. Variation in magnetic reluctance

Of the five torques, only the first two are significant during starting and accelerating, and only their characteristics will be discussed here.

## The amortisseur windings

These windings develop most of the starting and accelerating torque in motors of this type. This winding consists of a partially distributed cage winding, with bars imbedded in the pole faces and short circuited at each end by end rings. Varying the number, location and resistance of these bars will have a substantial effect on the torque and on the kVA input. In some cases a double cage, consisting of one row of shallow bars and one row of deepset bars, is used. These may be separate, or they may have common end rings as circumstances will dictate. Typical amortisseur windings are illustrated in Figure 15.

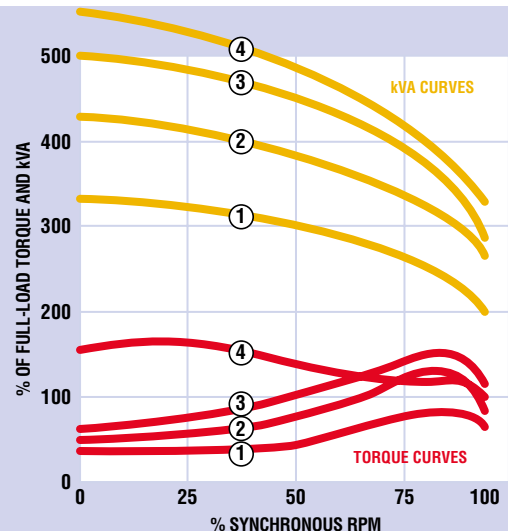

# The ABC's of Synchronous Motors Torque

**Figure 15**

*Modern amortisseur windings use a variety of bar materials and arrangements to secure the desired resistance and reactance to produce the required torques.*

As discussed previously, the application of polyphase power to the stator winding results in the development of a rotating magnetic field. Magnetic lines of force developed by this rotating magnetic field cut across the cage bars and generate voltages, causing currents at slip frequency to flow in them. The interaction between these currents and the rotating magnetic field develops torque, tending to turn the rotor in the same direction as the rotating magnetic field.

Recommended starting torques range from 40% to 200% of full load torque. See NEMA recommendations on torques for various synchronous motor applications.

Torque comes from the action of the flux produced by the stator. Getting more torque requires more flux and, therefore, more iron. More torque also results in more inrush. For any given motor, the effective resistance and reactance of the cage winding are the principal factors in determining motor torques. Typical starting and accelerating torques and their associated kVA values are shown in Figure 16.

The double cage motor was developed to give essentially constant pull-up torque. The shallow cage has high resistance and low reactance, while the deep cage has low resistance and high reactance. At standstill, slip frequency equals line frequency, and the high reactance of the deep cage forces most of the induced current to flow through the shallow cage, high resistance bars, resulting in high starting torque.

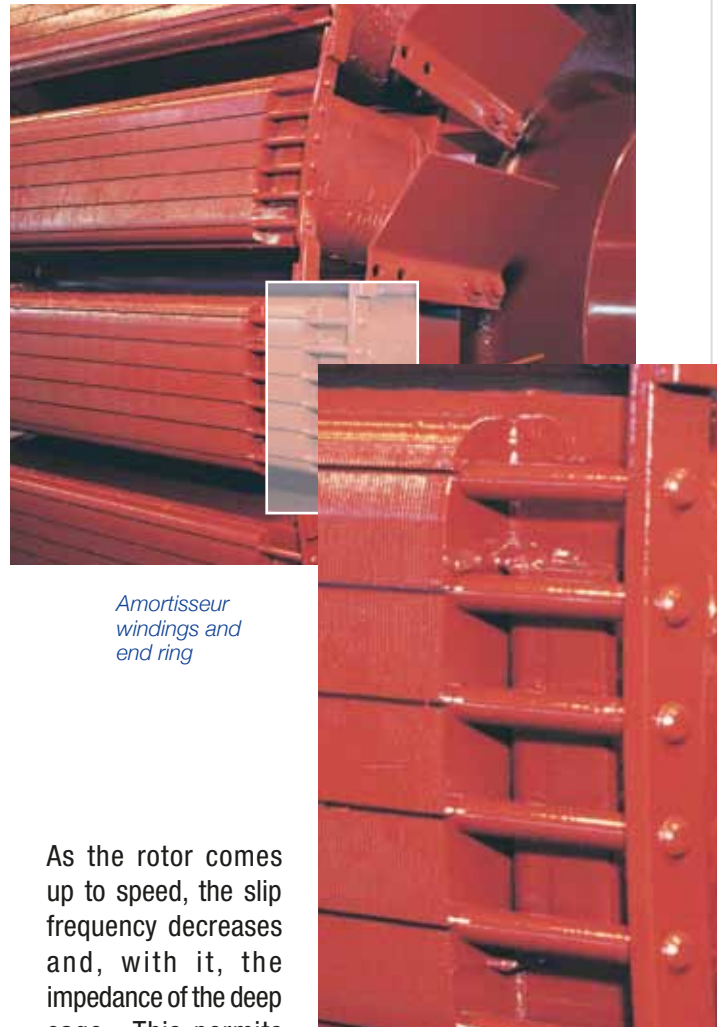

*Amortisseur windings and end ring*

As the rotor comes up to speed, the slip frequency decreases and, with it, the impedance of the deep cage. This permits more of the induced current to flow through the deep-set, low-resistance bars, resulting in high torques at speeds near pull-in. Figure 17 illustrates the resultant torques using this type of construction.

Ideal applications for double cage windings are those where the load is uniformly high during the entire accelerating period. Disadvantages include saturation, due to the number of cage bars in the pole head, and stress due to the differential thermal expansion in bars that are close together. Double cage motors are relatively uncommon.

**Figure 16** (left) Curves show starting torque and starting kVA of synchronous motors using various types of amortisseur winding constructions. For any given motor, the effective resistance and reactance of the cage winding are the principal factors in determining the shape of the curves, and the ratio of torque to kVA.

**Figure 17** (right) Curves show double cage torque resulting from high resistance upper cage winding, and low resistance, high reactance lower cage winding.

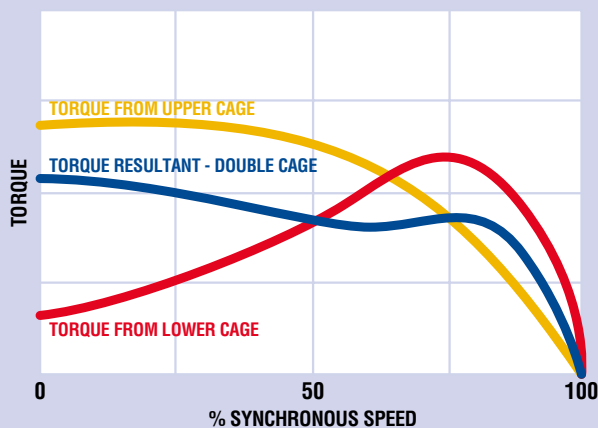

# The ABC's of Synchronous Motors

## Torque

### Field Windings

The amortisseur winding imparts squirrel-cage motor starting and accelerating characteristics to the synchronous motor. The field winding develops a torque similar to that of a wound rotor motor with a single-phase secondary circuit.

The single-phase characteristic results in two torque components, one rotating in the same direction as the rotor and one rotating in the opposite direction. The second component is positive in value to 50 percent speed and negative from that point to pull-in. Figure 18 illustrates the torque components and the resultant torque derived from the field windings. If a motor was built with a relatively weak cage, the dip in torque due to the effect of the negative rotating component could result in the motor not being able to accelerate much past half-speed.

During starting and accelerating, the field winding is short-circuited through a field discharge resistor to limit the induced field voltage. The ratio of this resistance to the field resistance has a significant effect on the starting torque, the torque at pull-in and, to a lesser degree, on starting kVA. Figure 19 shows the effect of varying the field discharge resistance on one specific motor. It will affect the negative rotating component of the field winding torque, and a high value of resistance may reduce it considerably. However, a high value of field discharge resistance results in a high induced voltage across the field winding. In extreme cases, as in the case of open-circuit field starting (infinite resistance) the induced field voltage may exceed 100 times the normal excitation voltage.

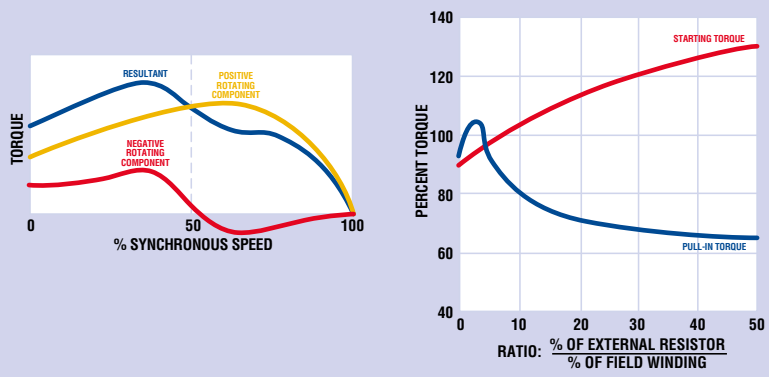

**Figure 18** Torque components and resultant torque derived from the field winding of a synchronous motor during starting.

**Figure 19** Effect of ratio of field discharge resistance to field resistance on the starting and pull-in characteristics of the motor.

### Pull-up Torque

Pull-up torque is the minimum torque developed from stand-still to the pull-in point. The pull-up torque must exceed the load torque (torque required by the driven machine) by enough margin to maintain a satisfactory rate of acceleration from stand-still to pull-in under the minimum expected voltage condition.

### Net Accelerating Torque

Net accelerating torque is the margin by which the motor torque exceeds the load torque from stand-still to the pull-in point.

In the case of high inertia loads, it is important that the starting time be determined so proper relaying action of overcurrent relays and amortisseur winding protective relays, etc., can be obtained.

Accelerating time from standstill to the pull-in point can be approximated by applying the following relationship:

$$\text{Accelerating time } t = \frac{WK^2 \times \Delta \text{rpm}}{308T} \text{ (seconds)}$$

- $WK^2$  = total inertia of the load and the motor in lb.ft.<sup>2</sup>
- $\Delta \text{rpm}$  = the change in speed (rpm<sub>2</sub> - rpm<sub>1</sub>)
- 308 = a constant
- T = net accelerating torque, lb. ft. from rpm<sub>1</sub> to rpm<sub>2</sub>
- t = the time increment to accelerate from rpm<sub>1</sub> to rpm<sub>2</sub>

Note the motor torque as a function of speed, the load torque as a function of speed, and the motor and load inertias. The latter are obtained from the manufacturers as constants; the former are most frequently illustrated as speed-torque curves.

Refer to Figure 20, which shows curves for a typical 600 hp. 900 rpm motor and a throttled centrifugal fan load. The total motor and load WK<sup>2</sup> (inertia) is given as 29770 lb.ft.<sup>2</sup>.

Net accelerating torque at any speed is determined by subtracting the load torque from the motor torques at that speed. By taking values at 10% intervals, starting at 5% speed and continuing to 95% speed for example, a reasonable approximation of acceleration time from standstill to pull-in speed can be calculated. Refer to Figure 21 for a tabulation from this example.



# The ABC's of Synchronous Motors

## Torque

During the starting period, the amortisseur winding must absorb energy. In addition to the energy required to overcome the load torque, energy must also be absorbed to accelerate the inertia of the rotating system. Since high temperatures that affect material strength can be realized in a short period of time, it is important that a means be provided for transmitting as much heat as possible into the pole body and also that the heat absorbed will not overheat the amortisseur winding. During starting the temperature rise of the amortisseur winding may be as high at 150°C. Quantitatively, the energy absorbed in accelerating a rotating mass is covered by this formula:

$$H = \frac{0.231 \times WK^2 \times (\text{rpm})^2}{(1000)^2}$$

H = Energy in kW seconds  
 WK<sup>2</sup> = Total WK<sup>2</sup>  
 rpm = Speed in revolutions per minute  
 0.231 = a constant

In the case of the motor and fan referred to above, the energy absorbed in the rotor, due to inertia, in bringing the unit to 95% of synchronous speed is:

$$H = \frac{0.231 \times 29,770 \times (855)^2}{(1000)^2} = 5020 \text{ kW seconds}$$

H is expressed in per unit by dividing the above by rated kW (rated horsepower x 0.746). Interestingly, two times H in per unit is the accelerating time if the accelerating torque is equal to rated torque. Applying this to our example: H = 11.2 and the average accelerating torque is 76%. Accelerating time (t) = 11.2/0.76 x 2 = 29.5 seconds.

Some types of loads, such as ball mills, have very low inertia values, but their load torque may approach that developed by the motor if the rate of acceleration and the accelerating torque is low. Large fans may have both high inertia values and appreciable torque requirements. In such cases, it is desirable to determine the total energy input to the rotor, both as a

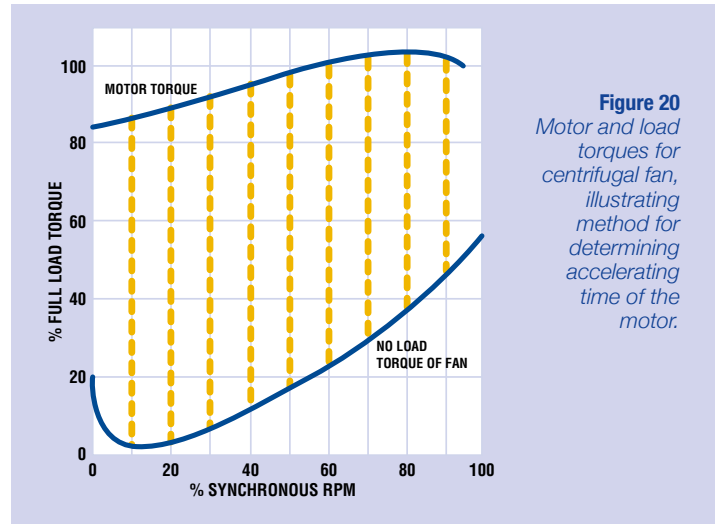

**Figure 20**  
 Motor and load torques for centrifugal fan, illustrating method for determining accelerating time of the motor.

% RPM	% Motor Torque	% Fan Torque	% Net Torque	Lb. Ft. Torque	Time in Seconds
5	86	5	81	2840	1.46
15	88	3	85	2980	2.78
25	91	6	85	2980	2.78
35	93	10	83	2920	2.84
45	97	14	83	2920	2.84
55	99	19	80	2800	2.96
65	102	25	77	2700	3.08
75	104	32	72	2520	3.3
85	104	40	64	2240	3.8
95	100	50	50	1750	4.75
					30.59

**Figure 21**

result of accelerating the inertia, and of overcoming the load torque. Since all of the torque developed by the motor must either accelerate inertia or overcome load torque, and since slip loss is a function of this torque and of slip, it is readily possible to determine this energy input.

Referring again to the motor and load characteristics covered by Figure 20 and Figure 21, we can proceed as follows:

$$\text{Slip loss} = 0.746 \times TM \times S \times \text{HP} \times t, \text{ in kilowatt seconds}$$

TM = % motor torque  
 S = % slip  
 t = Time at that torque

Note that slip loss is proportional to average slip and to average total motor torque (not net accelerating torque) for each 10% speed interval considered. As shown in Figure 21, total loss in the rotor is 6400 kW seconds.



# The ABC's of Synchronous Motors

## Torque

Since it was previously determined that the loss due to accelerating the inertia was 5020 kW seconds, we now determine the additional loss due to the load is 6400 - 5020 = 1380 kW seconds.

In some cases the speed of the driven unit will differ from that of the driving motor, because of belting or gearing arrangements. All WK<sup>2</sup> values used in determining accelerating time or energy absorption must be effective values referring to the motor speed.

Effective  $WK_1^2 = WK_2^2 \times \frac{(rpm_2)^2}{(rpm_1)^2}$

- Effective  $WK_1^2 = WK^2$  referred to the motor shaft rpm
- $WK_2^2 =$  Inertia of driven machine in lb. ft<sup>2</sup> @ rpm<sub>2</sub>
- rpm<sub>2</sub> = Speed of load shaft in revolutions per minute
- rpm<sub>1</sub> = Motor shaft speed in revolutions per minute

### Pull-in Torque

The pull-in point (when a synchronous motor changes from induction to synchronous characteristics and operation) is usually the most critical period in the starting of a synchronous motor. The torques developed by the amortisseur and field windings become zero at synchronous speed. They cannot pull the motor into step, so the reluctance torque and the synchronizing torque (resulting from exciting the field windings with direct current) take over.

### Reluctance Torque

Any magnetic object tends to align itself in a magnetic field so that the magnetic reluctance is at a minimum. There are as many positions of a salient pole rotor within the rotating stator magnetic field as there are poles. Below synchronous speed, a pulsating torque called reluctance torque is developed. It has a net average value of zero and a frequency equal to twice the slip frequency. This torque may lock a lightly loaded rotor into step and develop approximately 30% pull-out torque.

### Synchronizing Torque

When excitation is applied, definite polarity is developed in the rotor poles. If the slip is low enough, the attraction between unlike poles in the rotor and the stator will lock the rotor into step with the rotating stator magnetic field. Neglecting the influence of reluctance torque, the value of slip from which the motor will pull into step may be expressed as follows:

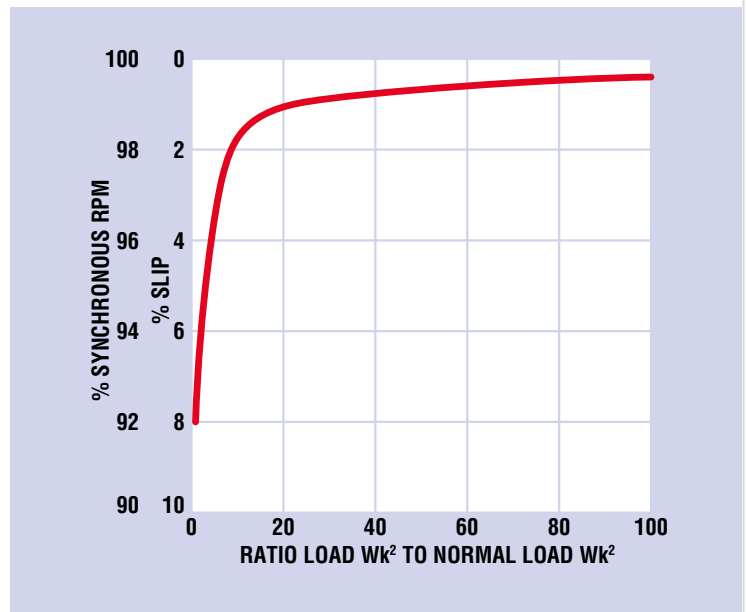

Figure 22 Relationship between load inertia and minimum slip for pulling into step of a specific synchronous motor.

$$S = \frac{C}{rpm} \times \frac{HP}{WK^2}$$

- S = Slip in % of synchronous speed
- WK<sup>2</sup> = Inertia of motor rotor plus load inertia
- C = Constant taking into account such factors as efficiency, power factor, etc.

The relationship between slip and inertia in a given motor is shown by the curve in Figure 22. The larger the inertia the higher the speed required to achieve synchronization.

### Load Inertia

Since load inertia is so important in determining the speed to which the motor must accelerate before pull-in is possible, NEMA has established normal load WK<sup>2</sup> values. These are covered by the formula:

$$\text{Normal load } WK^2 = \frac{3.75 \times HP^{1.15}}{(rpm/1000)^2}$$

Figure 23 illustrates the relationship between rated horsepower, speed and normal load WK<sup>2</sup>.

We may designate as “inertia factor” the ratio of actual load WK<sup>2</sup> to normal load WK<sup>2</sup>. This varies over a wide range. Typical values are shown in Figure 24.

NEMA defines pull-in torque as the maximum constant torque under which the motor will pull its connected inertia load into synchronism at rated voltage and frequency, when excitation is applied. This is sometimes referred to as “load” pull-in torque.



## The ABC's of Synchronous Motors Torque

From Figure 24, we note that the inertia factor of the connected load may vary from 1 to 100. For the specific motor covered by Figure 22, pull-in can be affected at 8% slip with normal load  $WK^2$ . However, with an inertia factor of 100, the motor must reach 99.2% of synchronous speed on the cage winding before the motor will pull into step on application of excitation. A motor will therefore have a much higher “load” pull-in torque when driving a load having a low inertia factor than with a load having a high inertia factor.

It is rarely possible for the motor manufacturer to shop test the pull-in torque of a motor under actual load conditions. As a practical substitute, the motor torque developed at 95% speed (“nominal” pull-in torque) is used as a design and test point to predetermine the pull-in capability of the motor. Since the torque at 95% speed is a steady state condition, and actual pull-in is transient, it is necessary to take into account inertia, motor reactance and other factors.

To investigate the relationship of “load” pull-in torque and “nominal” pull-in torque, assume an application of a centrifugal fan having an inertia factor of 20, and connected to a 1000 HP, 1200 rpm motor. The fan load at synchronizing speed, with closed discharge, is 50% of full load torque. Assume it is determined that the motor slip must not exceed 1.8% if the motor is to pull into step on application of excitation. In this case, the effect of reluctance torque is neglected and it is assumed excitation may be applied at the worst phase angle for synchronizing.

In Figure 25, point A is the speed which must be attained on the amortisseur winding to permit synchronizing. Assume that the torque developed by the amortisseur winding is directly proportional to slip from zero slip (synchronous speed) to 5% slip (95% speed). We can then extend line A as a straight line to B, at 95% speed. Point B will then determine the torque required at the 95% speed point (in this case 135%). This value is the “nominal” pull-in torque.

If, instead of the centrifugal fan discussed above, a motor of this rating were connected to a centrifugal pump, again having a load at synchronizing speed of 50% but having an inertia factor of 1, it would pull into step, on application of excitation, from a speed of 96% or at a slip of 4%. This is indicated by point C. The corresponding “nominal” pull-in torque at point D is 63%.

This illustrates two applications, each having load pull-in torques of 50%, one requiring 135% “nominal” pull-in torque and the other 63% “nominal.” The difference is due to the connected inertia load.

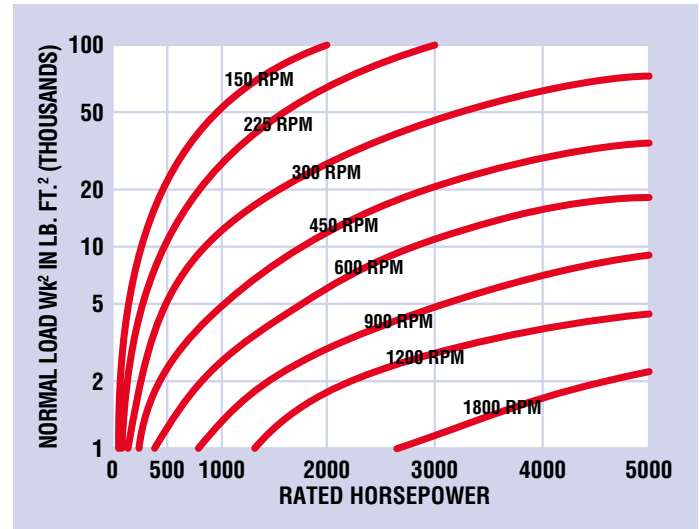

Figure 23 Curves show the relationship between rated horsepower, speed and normal load  $WK^2$  for synchronous motors.

Type of Load	(Inertia Factor) Load $WK^2$ /Normal Load <sup>2</sup>
Ball Mill	3
Band Saw	100
Centrifugal Fan	Dec-60
Chipper	30-100
Pump, Centrifugal	1
Air Compressor	10
Hammermill	25

Figure 24

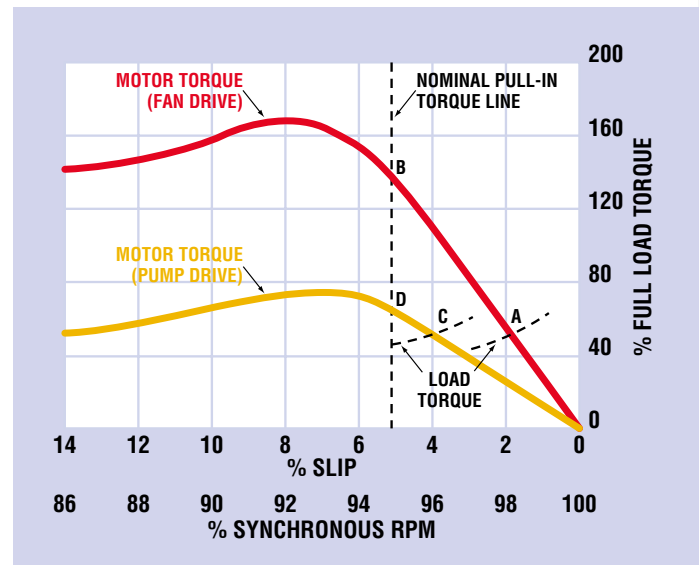

Figure 25 Relation of load and “nominal” pull-in torque, which is the torque required at 95% speed of pulling into step.



# The ABC's of Synchronous Motors Torque

Figure 26 shows various common loads having typical horsepower and speed values, typical inertia factors and corresponding values of maximum permissible slip for synchronizing, with typical load pull-in torque values, and corresponding nominal pull-in torques.

The load pull-in torque value (indicated in column 6) for chippers is merely friction and windage as shippers must be started, accelerated, and synchronized unloaded.

In some cases, in order to obtain an adequate rate of acceleration, it will be desirable to design for higher nominal pull-in torque values than those shown in column 7 of Figure 26.

Frequently, where it has been difficult for the motor to pull into step on application of excitation, raising the applied excitation voltage will facilitate pull-in.

During the starting interval, the field winding is short-circuited through the field discharge resistor. As shown in Figure 27, the frequency of the field discharge current is line frequency (60 Hertz on a 60 Hertz system) at standstill, declining to 3 Hertz at 95% speed. The time constant of the field winding is quite long. The excitation current builds up relatively slowly when excitation voltage is applied. As shown in Figure 28, if the excitation is applied at the proper interval of the field discharge current wave, it will readily build up to a maximum value, being assisted by the field discharge current, thus pulling the rotor into step promptly and with a minimum of line disturbance. Improved synchronization can be obtained by proper timing of field application.

1	2	3	4	5	6	7
<b>Ball Mill</b>	1000	180	4.0	4.3	100	115
<b>Fan</b>	1000	1200	20	1.8	50	138
<b>Pump</b>	1000	1200	1.0	4.0	50	63
<b>Centrifugal Compressor</b>	2500	900	15	1.8	50	138
<b>Chipper</b>	1500	277	50	1.0	10	50

1. Type of load
2. Horsepower
3. RPM
4. Assumed inertia factor
5. Maximum slip from which motor will pull-in, in percent
6. Load torque required at pull-in
7. Nominal pull-in torque

Figure 26

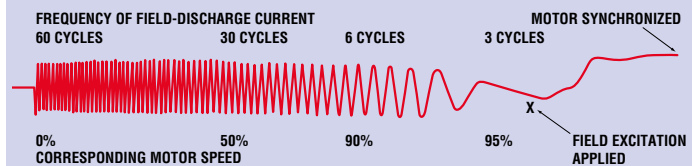

Figure 27 Frequency of the current induced in the field winding of a synchronous motor declines as the motor comes up to speed.

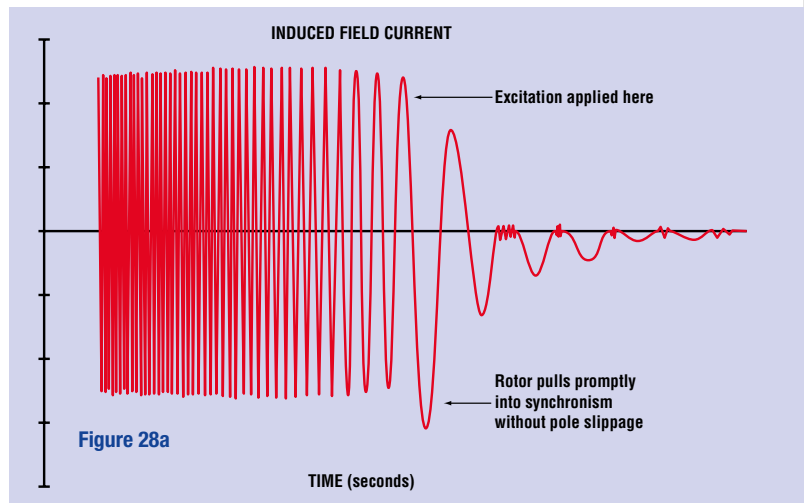

Figure 28a Oscilloscope shows synchronizing of the motor by application of dc excitation. If the point of application anticipates the interval before synchronizing as shown, the excitation will readily build up to pull the rotor into step smoothly.

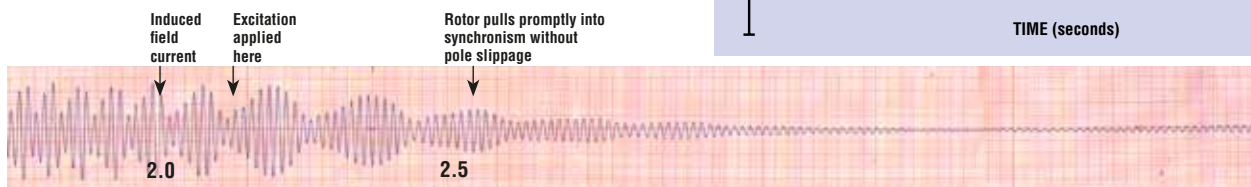

Figure 28b Stator Current. Rotor pulls into synchronism with minimum stator current. (Note: Pulsations of current after synchronism are oscillations due to very large flywheel effect of the load.)

# The ABC's of Synchronous Motors Torque

## Synchronous Torque

The unlike poles of the stator rotating magnetic field and of the rotor lock together and operate simultaneously. Figure 29 represents conditions of typical motor at no load, rotating in a counter-clockwise direction. The South pole, S, of the rotor is directly opposite the North pole, N, of the stator. At that point all torques are zero. However, at any displacement from that position, as with the rotor pole dropping back to the position S1, a resultant torque along curve C will be developed. This is the result of torque curves A and B.

The torque curve A is due to magnetic reluctance. It becomes zero at 90° displacement and is negative from that point to 180°. Torque curve B is due to definite polarity from the excited poles. It becomes maximum at 90° and zero at 180°.

The resultant C curve is the synchronous torque. It reaches a maximum at approximately 70° lag of the rotor behind the rotating stator magnetic field and is unstable from that point to 180°. If the load suddenly increases, the rotor will pull back and oscillate at its natural frequency about the next load point. There will be a slight variance in the speed for a moment.

Synchronizing power is measured in kilowatts along the line d-m. The angle of lag is the angular distance between S and S1. In this case we assume it to be 0.56 radian (32°) at full load. Then synchronizing power Pr is defined as:

$$Pr = \frac{kW}{d}$$

Pr = Synchronizing power in kilowatts per radian at full load displacement

kW = Power measured at motor shaft  
d = Displacement in electrical radians

Pr is important because it is a factor of the stiffness of magnetic coupling between the stator and the rotor. It affects the pull-out torque and also the neutral frequency. Pr is approximately HP x 1.35 for unity power factor, and HP x 1.8 for 0.8 leading power factor motors.

**Figure 29** Diagram shows conditions in a synchronous motor when operating in synchronism and at no load. When the motor is loaded the rotor will drop back along the red curve C, the curve of synchronous torque, sufficiently to develop the load torque. C is the result of magnetic reluctance torque, A, and the definite polarity torque, B. The maximum synchronous torque is reached at about 70 electrical degrees lag of the rotor.

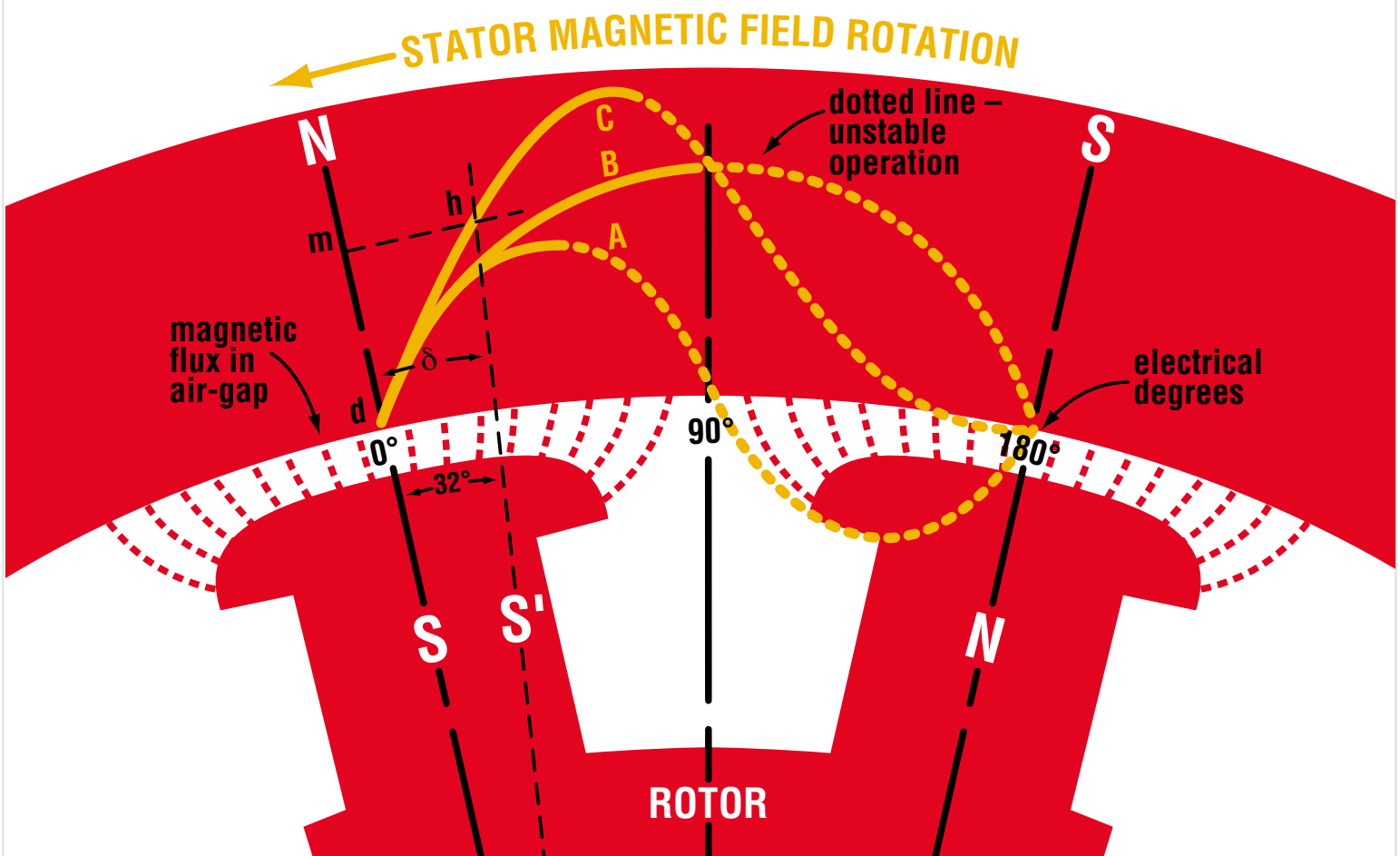

# The ABC's of Synchronous Motors Torque

## Pull-out Torque

NEMA defines pull-out torque of a synchronous motor as the maximum sustained torque which the motor will develop at synchronous speed for one minute at rated frequency and normal excitation. Normal pull-out torque is usually 150% of full load torque for unity power factor motors and 175% to 200% for 0.8 leading power factor motors. It can be increased by increasing the field strength, which generally means increasing the air-gap and flux density. This usually means increasing the physical size of the motor.

As shown in Figure 29, any sudden increase in load is accompanied by an increased angle position of the rotor and stator and a corresponding increase in line current. Due to transformer action, there is a transient increase in excitation and pull-out torque. This increased value disappears in a few cycles so it can be effective only on instantaneous peaks. However, the change in excitation can be used to “trigger” an increase in excitation voltage, thus tending to maintain the value of excitation established by transformer action.

The reactance of the motor windings will determine the amount of increase in excitation current and pull-out torque for a typical motor. The effect is shown in Figure 30.

## Pulsating Torque

Since the rotor of a salient pole synchronous motor has poles and interpole spaces, its magnetic circuit varies from point to point around the rotor. The instantaneous starting or accelerating

torque is greater when the flux set up by the stator passes a rotor position where the poles provide a good flux path. Less torque is developed when passing between poles. It is common to show a torque curve as a smooth curve from zero to 95% speed; this is really the average torque. At a given speed, the torque varies from the maximum to minimum at twice slip frequency. At standstill, the torque pulses at 120 Hz. As shown in Figure 31, the torque at 95% speed has a pulsating component at  $2 \times 60 \times (1.00 - 0.95) = 6$  Hz; one cycle every 0.167 seconds. At 80% speed this is  $2 \times 60 \times (1.00 - 0.80) = 24$  Hz, or 0.042 seconds per cycle. Figure 32 demonstrates torque pulsation at 80% speed.

The pulsating component of torque needs to be carefully evaluated as to its effect on the combined motor driven equipment. A typical pulsating torque is approximately 20% of rated torque. Typically, we have the mass of the motor, the gear and the load (i.e. compressor) all connected by the shaft. Each individual part has a natural frequency as well as the combinations. The responsibility to avoid a torsional natural frequency that is near running speed is that of the system designer. Further, special consideration has to be given to the pulsating torque in certain applications. For example, large 6 pole motors driving compressors frequently have a resonance between 60 and 80% speed. Fortunately, it is only present during starting. If the start-up is fast, the resonance has little time to build up. The motor manufacturer provides curves of the average and the pulsating torque so that an overall system analysis can be made. Figure 33 is a representation of a torque vs. speed curve. Shaft sizes may be adjusted or the coupling changed, but the pulsating torque will still be there.

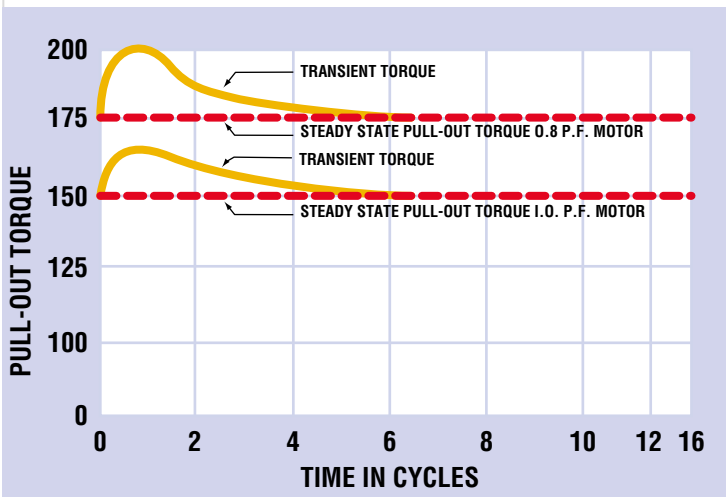

Figure 30 Transient pull-out torque of a synchronous motor. This torque is influenced by reactance of the motor windings.



Synchronous motors 3000 HP at 164 RPM with DPG enclosures driving a dual pinion ball mill at an iron ore mine.

# The ABC's of Synchronous Motors

## Torque

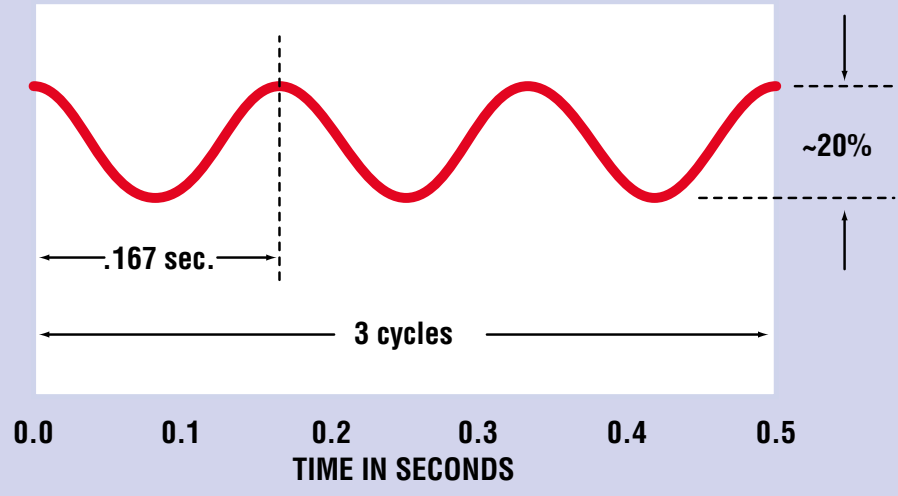

**Figure 31**  
Pulsations in total torque due to reluctance variations in magnetic circuit at 95% speed; 6 Hz. or .167 sec./cycle.

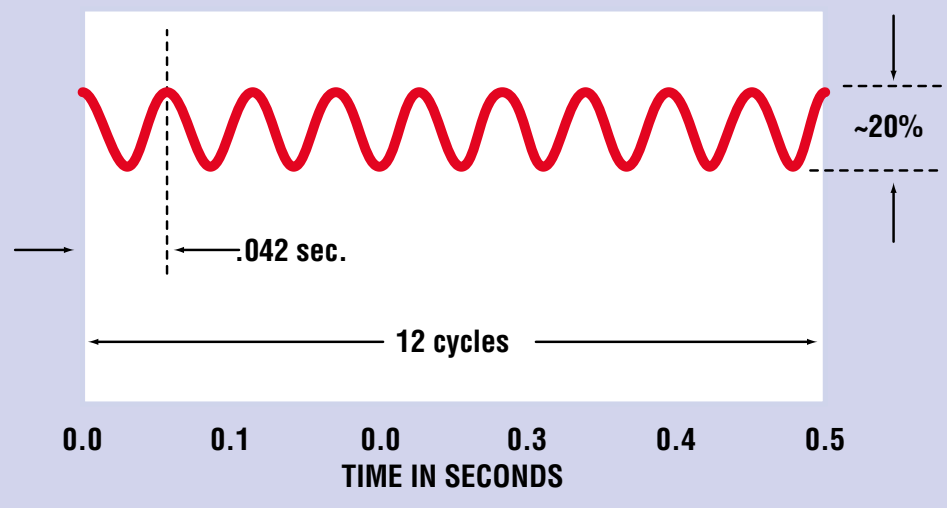

**Figure 32**  
Pulsations in total torque due to reluctance variations in magnetic circuit at 80% speed; 24 Hz. or .042 sec./cycle.

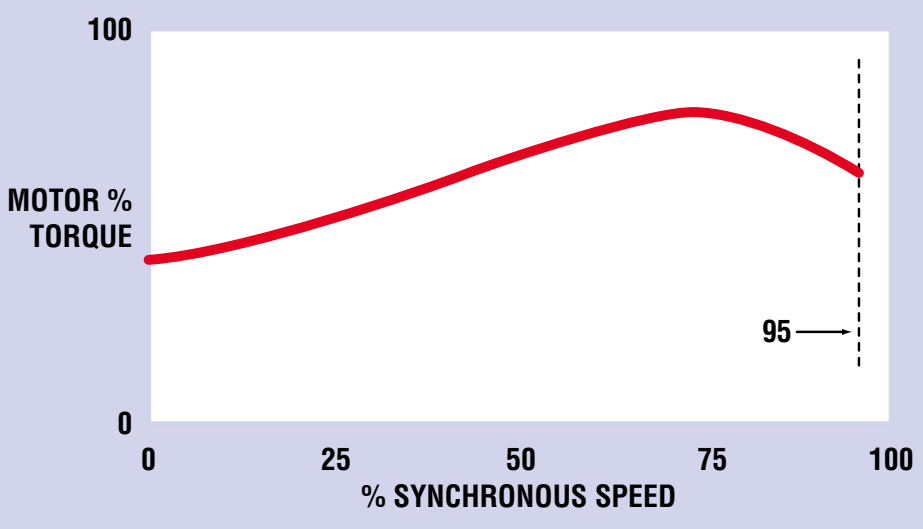

**Figure 33**  
Typical speed-torque curve showing average torque.



# The ABC's of Synchronous Motors

## Starting & Excitation

### Starting & excitation methods for synchronous motors

#### Starting

As will be noted from the application section, the starting (zero speed) torques required of salient-pole industrial synchronous motors range from 40% to 200%.

The required pull-in torque depends upon the load torque and the total inertia. As covered in the previous section, the nominal pull-in torque is the actual torque the motor develops at 95% speed.

The starting kVA depends on both the starting torque and the nominal pull-in torque. For a given starting torque, the starting kVA of a synchronous motor in percent of the full-load kVA will increase with an increase in the ratio of nominal pull-in torque to starting torque. Figure 34 shows some typical values.

% Starting Torque	% Nominal Pull-in Torque	% Starting kVA
80	60	355
80	80	410
80	100	470

Figure 34

The starting kVA of synchronous motors often taxes the capacity of the generating or distribution system to which it is connected.

Extreme care must then be taken in analysis of the system's capacity, torque requirements, starting kVA, and starting method.

Full-voltage starting, due to its simplicity, should be used wherever possible. Most systems can stand dips of up to 20%. System capacities are usually expressed as MVA short circuit capacity. A quick approximation of the voltage dip during starting can be made by converting the motor inrush to MVA as follows:

$$\text{SCMVA} = \text{System short circuit capacity in MVA}$$

$$\text{MMVA} = (\% \text{ of motor inrush}/100) \times (\text{motor kVA}/1000)$$

$$\text{MVA} = \text{motor starting kVA}$$

$$\text{Motor kVA} = \text{HP} \times 0.746 / (\text{P.F.} \times \text{Eff.})$$

$$\% \text{ dip} = \text{MMVA} \times 100 / (\text{SCMVA} + \text{MMVA})$$

In some cases, a reduction in starting kVA is necessary to limit voltage dip. Line diagrams for various reduced kVA starting methods are illustrated in Figure 35.

Figure 36 shows motor voltage, line kVA and motor torque relationships for various methods of

#### Full-voltage

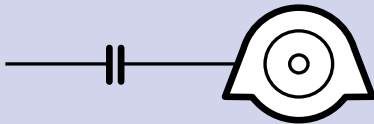

Full-voltage starting should always be used unless (1) limited capacity of power systems makes reduced kVA starting necessary, or (2) torque increments are required in starting.

#### AUTOTRANSFORMER

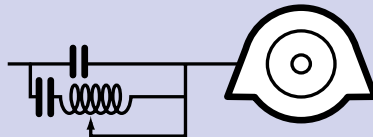

Line kVA is reduced approximately as the square of the motor terminal voltage, as is the motor torque. Closed transition autotransformer starters avoid the line surges experienced with earlier open-transition switching.

#### REACTOR

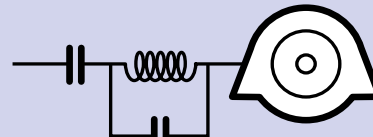

Line kVA is reduced approximately as the motor terminal voltage, but torque is reduced as the square of the voltage. The starter has the advantage of simplicity and closed transition switching.

Figure 35 Common starting methods for synchronous motors.

Type of Starting	Motor Voltage in % of Full Voltage	Line kVA in % of Full Voltage kVA	Motor Torque in % of Full Voltage Torque
Full Voltage	100	100	100
"Reduced Voltage "	78	60	60
Reactor	60	60	36

Figure 36



## The ABC's of Synchronous Motors Starting & Excitation

starting. Figure 37 shows full voltage starting kVAs for 1.0 P.F. motors at high and low speeds.

It is important that sufficient torque be developed to start and accelerate the load properly. In some applications, incremental starting, which employs part winding, reactor, or autotransformer is used. The motor need not start on the first step, but additional torque increments are successively applied until the motor starts and accelerates. This method eases the mechanical shock on driven equipment and, on regulated systems, permits restoration of normal voltage before application of the next torque and kVA step.

The motor pulls into step on application of excitation to the rotor field winding. The starting method applies excitation at the proper speed and phase angle to assure proper synchronizing.

### Excitation

All synchronous motors need a source of direct current for their field winding. Historically, this was supplied by an exciter, a specialized dc generator which may have been direct-connected to the shaft of the motor so that if the motor is running, dc is available. In the past, conventional exciters were small dc generators with commutators to convert the generated voltage to dc. Brushes allow the current to come from the exciter to the stationary control center. The current is then routed back through slip-rings and brushes to the motor field. This system works very well except for a minor nuisance,

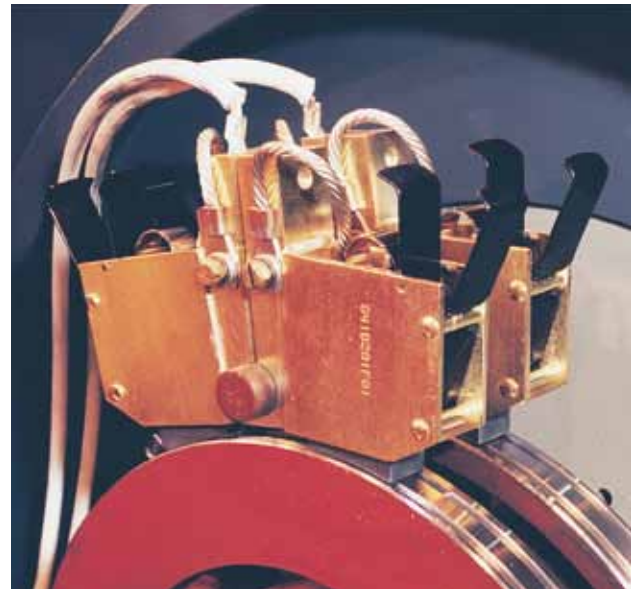

*Collector rings and brushes are not required or used with brushless excitation.*

the brushes. Brushes can last as long as a year, but there is the carbon dust to clean up and continual operator visual inspection is required. Occasionally conditions will change and brushes will wear rapidly. The selection of the proper grade of brush depends on current density, ring material, ring speed, humidity, brush pressure, and many other factors. It may take a long time to find the right brush. Put this together with the brush and ring maintenance and there's an opportunity for a better method.

### APPROXIMATE FULL-VOLTAGE STARTING kVA OF UNITY POWER FACTOR\* SYNCHRONOUS MOTORS (In % of full-load kVA of motor; for various starting, pull-in and pull-out torque; for 50 and 60 Hertz motors)

High-Speed Motors (500 to 1800 rpm)				Low-Speed Motors (450 rpm and lower)			
Starting	% Torques Pull-in**	Pull-out	% Starting kVA at Full Voltage	Starting	% Torques Pull-in**	Pull-out	% Starting kVA at Full Voltage
50	50	150-175	375	40	40	150	250-325
50	75	150-175	400	50	75	150	350-375
75	75	150-175	400	75	110	150	500
75	110	150-175	500	100	50	150	375-400
110	110	150-175	500	160	110	150	575
125	110	200-250	550-600	100	110	200-250	600-650
150	110	150-175	550	125	110	200-250	600-650
175	110	200-250	600-650	125	125	200-250	600-650

\* For 0.8 power factor motors, the percent starting kVA will be approximately 80% of the values shown.

\*\* The above pull-in torques are based on normal load WK<sup>2</sup>.

NOTE: The percent starting kVA in the tables above are approximate for estimating purposes only. Specific values for particular motors can be furnished

**Figure 37**

## The ABC's of Synchronous Motors Starting & Excitation

### Brushless excitation is more reliable with no brush or collector ring maintenance

By the 1960s, solid state diodes and thyristors had advanced to where they could carry the current and block the voltages as required. It was then that Electric Machinery Manufacturing Company developed the brushless exciter (see Figure 38). The exciter is physically direct connected as before. The rotor has a three phase ac armature winding. The stationary field winding is on poles on the stator and is connected to a variac and rectifier or equivalent source of variable dc. The generated ac current is directly connected along the shaft to a rotating diode wheel, where it is rectified to dc before going to the motor field. The magnitude of the motor field current is adjusted by changing the current to the stationary exciter field.

The most amazing part of this design was the mounting of the control on the rotor. Starting a synchronous motor requires shorting the field with a discharge resistor and blocking the dc current until the rotor is near full speed. The dc current is then applied and the discharge resistor is removed. For the brush type machines this was in a control cabinet the size of a four drawer file cabinet. Now it is a small package on the rotor.

To show what is required of the control, consider the starting of a synchronous motor. The ac breaker closes, applying three phase voltage to the stator winding. The stator winding has been wound to form a number of magnetic poles

depending on the rated speed of the motor. These poles on the stator cause a magnetic field to rotate at rated speed. The rotor has not started to move, so the field winding and cage are swept by the rotating magnetic field. This will induce a very high voltage (thousands of volts) in the field winding. To avoid this, the field is shorted by a discharge resistor. In addition, this resistor is designed to give additional pull-in torque. As the rotor accelerates, the frequency of the discharge current is proportional to the difference in speed between the stator flux and the rotor winding (slip). At synchronous speed there is no slip, so no voltage is induced and no torque is produced by the cage. Since there is some load torque, the speed never reaches synchronous speed but reaches equilibrium where the decreasing cage torque matches the load torque. At this point, dc is applied to the field, creating strong magnetic North and South poles. These are attracted to the opposite magnetic poles on the stator. If the attraction is great enough, the rotor with its inertia will be pulled up to synchronous speed. The rotor is thereafter locked to the rotating stator magnetic field.

### Field Application System

Functions of Field Application System:

1. Provide a discharge path for the current induced in the field of the motor during starting, and open this circuit when excitation is applied.
2. Apply field excitation positively when the motor reaches an adequate speed. This excitation should be applied with such polarity that maximum torque will be obtained at the time of pull-in.
3. Remove excitation and reapply the field discharge resistor immediately if the motor pulls out of step.

The circuit for accomplishing this is shown in Figure 39. The field discharge resistor protects the motor field winding from the high voltage induced in starting and provides the voltage source for the control circuit. The ac output of the exciter is converted to dc by the rotating rectifier diodes. This output is switched on or off to the motor field winding by silicon controlled rectifier SCR-1, which is gated by the control circuit.

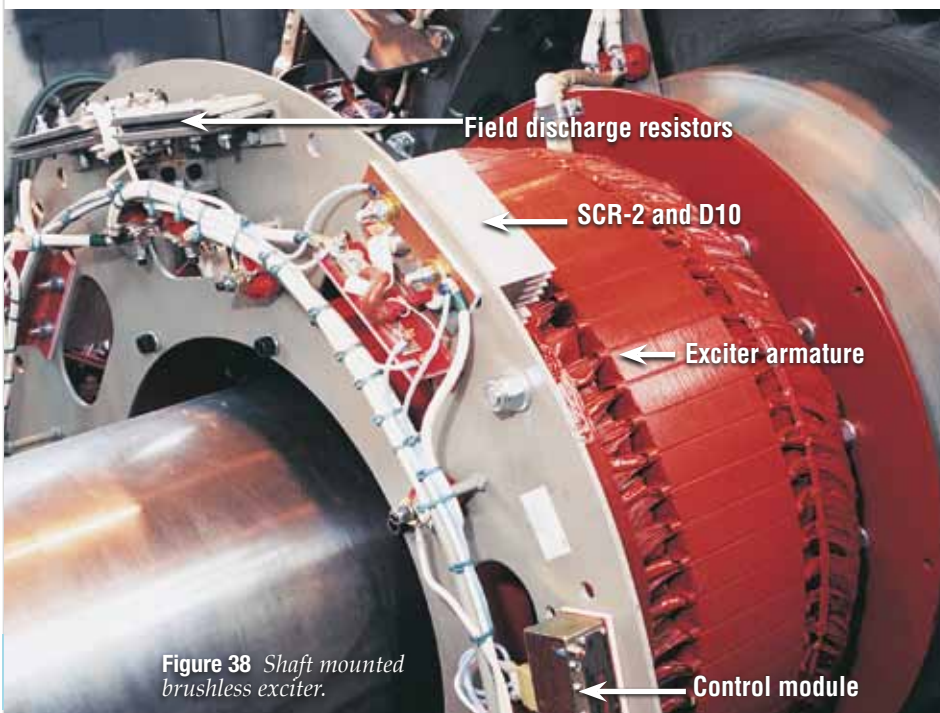

Figure 38 Shaft mounted brushless exciter.

## The ABC's of Synchronous Motors Starting & Excitation

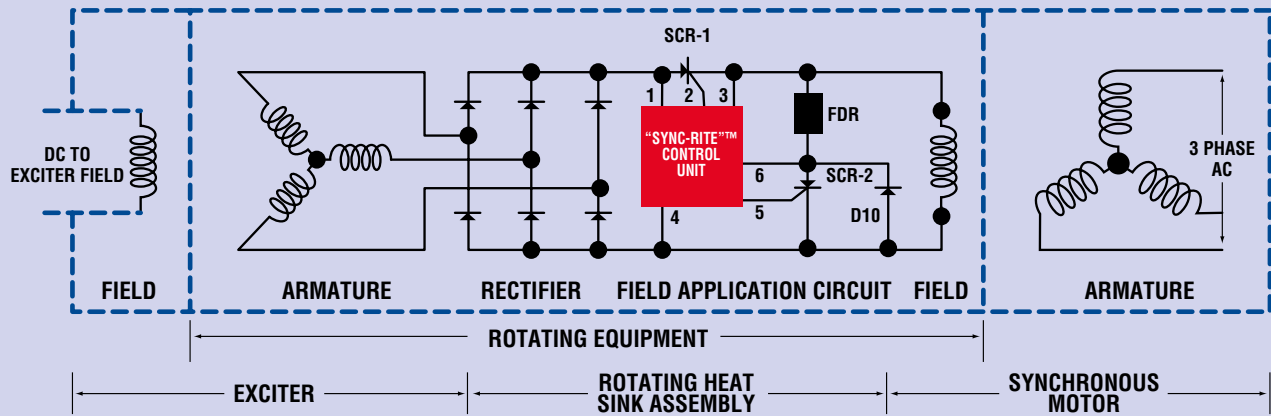

Figure 39

### Control Circuit

The control circuit keeps the SCR-1 from firing until the induced field current frequency is very low, representing a close approach to synchronous speed, and then fires the rectifier SCR-1 at the proper time and applies excitation to the synchronous motor field. At the same time, the field discharge resistor is removed from the circuit. This is done by the inherent operating characteristics of silicon controlled rectifier SCR-2. This frequency sensitive part of the control circuit assures that field excitation is applied at the proper pull-in speed for successful synchronizing and at the proper polarity to give maximum pull-in torque with minimum line disturbance.

The control circuit operates to remove excitation should the motor pull out of step due to a voltage step or excessive mechanical load. On the first half cycle after pull-out, the induced field voltage causes the net field current to pass through zero, turning SCR-1 off, automatically removing excitation. SCR-2 operates to connect the field discharge resistor back in to the circuit. During this time, the motor operates as an induction motor. When conditions permit, field is then reapplied as during starting.

In Figure 39, the voltage from the exciter-rectifier is blocked by SCR-1 until the point of synchronization. The field has an alternating voltage causing current to flow first through SCR-2 and the discharge resistor. On the next half cycle, current flows through the diode and discharge resistor. The control circuit waits until the frequency drops to the preset value, indicating the rotor is at an adequate speed. Then, after a North pole on the stator is in the right position to be attracted to what will be a South pole on the rotor, it triggers SCR-1 to apply excitation.

If the rotor does not synchronize, it will slip a pole; the induced field voltage will oppose the exciter voltage causing the current to go to zero, turning SCR-1 off. SCR-2 is turned on only at a voltage higher than the exciter voltage so it will not be on when SCR-1 is on.

Occasionally, a lightly loaded motor will synchronize without excitation being applied. This is due to the reluctance torque. Reluctance torque results from the magnetic circuit having less reluctance when the poles line up with the stator flux. The EM design includes a "zero slip" circuit to apply excitation in these situations.

While this may seem complex, it has proven to be a highly reliable system.

### Features of the brushless exciter

1. No brushes, no carbon dust problems, no brush maintenance.
2. No commutator or slip rings to resurface.
3. Completely automatic field application at the best angle for sure synchronization.
4. Removal of excitation and application of field discharge resistor in the event of out of step operation and automatic resynchronization.
5. No sparking. Can be used in hazardous areas.
6. No field cubicle with FDR and field contactor to maintain.



# The ABC's of Synchronous Motors Applications

## *Starting & excitation methods for synchronous motors*

Synchronous motors can handle any load which can be driven by a NEMA design B squirrel-cage motor. Whether they should be used for any specific application is a matter of some investigation. A rough rule of thumb is that synchronous motors are less expensive than squirrel-cage motors if the rating exceeds 1 HP per rpm. However, that considers only initial cost and does not take into account:

1. Higher efficiency of the synchronous motor.
2. Power factor improvement of the synchronous motor.

These two factors become important at speeds below 500 rpm where induction motor characteristics leave much to be desired. On the other side of the balance are these:

3. Necessity for excitation source and field control means for the synchronous motors.
4. Relatively low torque/kVA efficiency in starting.
5. Slightly greater maintenance cost, especially with motors with slip rings and brushes.



A few general rules may be established as a preliminary guide in selection of synchronous vs. induction motors, but specific local conditions must govern:

1. If especially low starting kVA, controllable torque or adjustable speed are desired, a synchronous motor and slip coupling may be used.
2. At 3600 rpm, synchronous motors are sometimes used from 10,000-20,000 HP. Above that range they are the only choice.
3. At 1800 rpm, motors show an advantage above 1000 HP. From 2000-10,000 HP, synchronous motors are used if power factor improvement is especially important. Above 15,000 HP, they are the only choice.
4. Induction motors for operation below 500 rpm have lower efficiency and a lower power factor. Synchronous motors are built at unity or leading power factor and with good efficiencies at speeds as low as 72 rpm. For direct connection in ratings above 1000 HP and in speeds below 500 rpm, the synchronous motor should be the first choice for compressors, grinders, mixers, chippers, etc.

Figure 40 is a general sizing chart for synchronous and induction motors.

Leading power factor motors are slightly less efficient than unity power factor motors, but they do double duty. Their application depends on the necessity for power factor correction.

Induction motors require from 0.3 to 0.6 reactive magnetizing kVA per HP of operating load. 0.8 Leading power factor synchronous motors will deliver from 0.4 to 0.6 corrective magnetizing kVA per HP depending on the mechanical load carried. Equal amounts of connected HP in induction motors and 0.8 leading power factor synchronous motors will result in approximate unity power factor.

*Synchronous motors 7000 HP at 327 RPM with TEWAC enclosures driving grinders at a paper mill.*

# The ABC's of Synchronous Motors

## Application

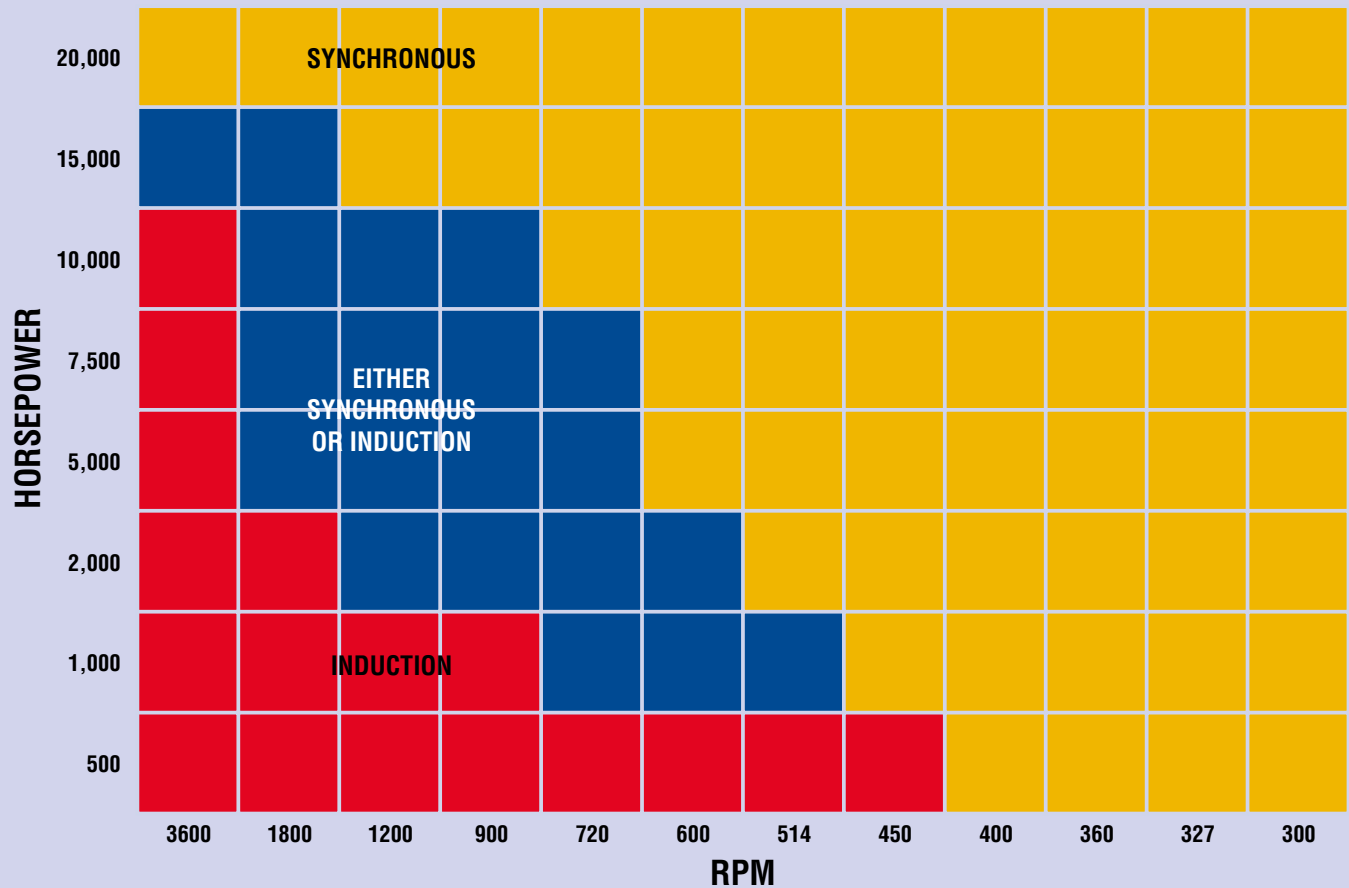

### Synchronous motors for air and gas compressors and vacuum pumps

Air and gas compressors and vacuum pumps may be reciprocating, rotary or centrifugal. Synchronous motors may be used with any of these types. Detailed application information follows:

#### Reciprocating compressors and vacuum pumps

Many more synchronous motors are direct connected to reciprocating compressors than are applied to all other types of loads combined. Factors contributing to this are:

1. Low starting and pull-in torque requirement of unloaded reciprocating compressors.
2. Elimination of belt, chain and gear drives.
3. High efficiency of low speed synchronous motors direct connected to compressors.
4. Power factor of low speed Synchronous motors direct connected to compressors.

5. Minimum floor space requirement.
6. Low maintenance cost.

Motors designed for direct connection to reciprocating compressors are usually engine type or single bearing construction. The stator is mounted on soleplates set in the foundation. A special case is the flange-mounted motor in which the stator frame is mounted on a flange on the compressor frame. In either case, torque requirements are usually within the range of normal design, low speed motors. See Figure 41.

The torque values may be exceeded for certain compressors and vacuum pumps; the manufacturer should be checked for specific values.

NEMA Recommended Torques for Reciprocating Compressors	Torques in % of Full-Load Torque		
	Starting	Pull-in	Pull-out
Air or Gas - Starting Unloaded	40	30	150
Vacuum Pumps - Starting Unloaded	40	60	150

Figure 41

# The ABC's of Synchronous Motors Applications

**Figure 42**

Oscillogram of synchronous motor driving a reciprocating compressor. Line A is envelope of current wave, B-C is current pulsation. B-C divided by rated full-load motor current is percent pulsation = 55.2%.

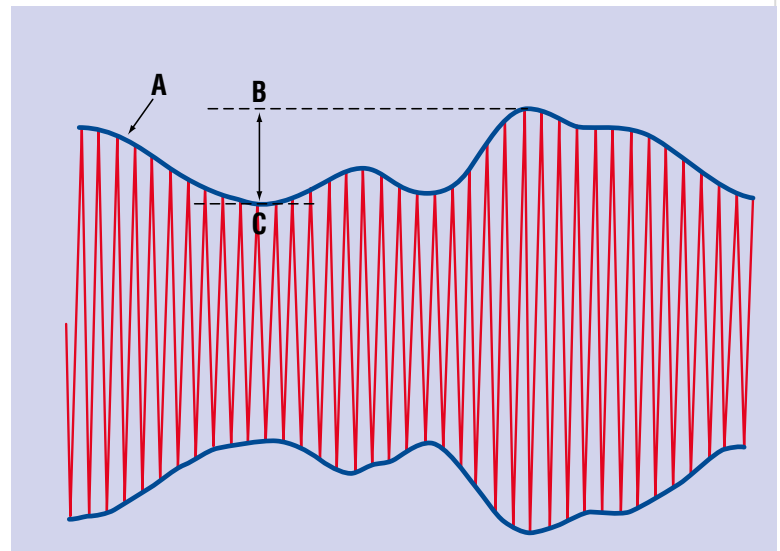

## Current pulsation

A reciprocating compressor has a varying torque requirement per revolution, depending on number of cylinders, crank angle, etc. As discussed previously, the angle of rotor lag and the amount of stator current vary with torque. There will be a cyclic pulsation of the load current during each revolution. This in itself is not too objectionable, but excessive current pulsation may result in appreciable voltage variation and thus affect lights or other devices sensitive to voltage change.

Present standards limit current pulsation to 66% of rated full-load current, corresponding to an angular deviation of approximately 5% from a uniform rotative speed. The current pulsation is the difference between maximum and minimum values expressed in percent of full-load current. Figure 42 shows an actual oscillogram of current input to a synchronous motor driving an ammonia compressor.

In some cases, step unloading of compressors involving successive unloading of various cylinder ends is used. This introduces additional irregularity into the crank effort and usually increases the current pulsation.

## Natural frequency

Any system having mass in equilibrium and having a force tending to return this mass to its initial position, if displaced,

will tend to have a natural period of oscillation. The common pendulum is a good example.

The natural frequency of this oscillation in a synchronous motor is determined by the formula:

$$NF = \frac{35200}{N} \sqrt{\frac{Pr \times Hz}{WK^2}}$$

- NF = Natural frequency in oscillations per minute
- N = Synchronous speed in revolutions per minute.
- Pr = Synchronizing power
- Hz = Line frequency in CPS
- WK<sup>2</sup> = Flywheel effect in foot pounds squared

It is assumed there is no effective damping and the motor is connected to an infinite system. This natural frequency should differ from any forcing frequency by at least 20%.

## Compressor factor

Neglecting inertia and damping forces, a single cylinder, double-acting or a two cylinder, single-acting compressor will have a crank effort diagram similar to Figure 43. A two cylinder, double-acting or a four cylinder, single-acting crank effort diagram is illustrated in Figure 44.

**Figure 43**

Crank effort diagram for a one cylinder, double-acting compressor, or two cylinder, single-acting compressor.

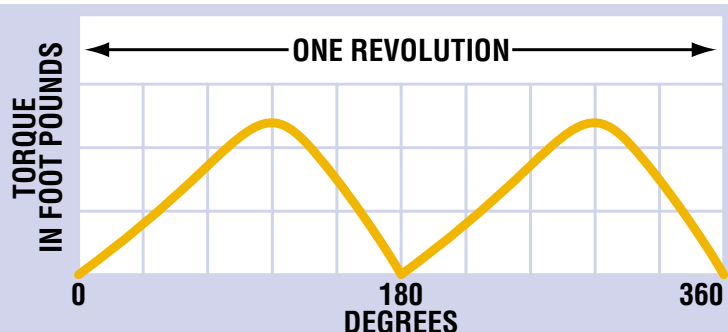



## The ABC's of Synchronous Motors Application

Various factors may tend to disturb the symmetry of the torque effort diagrams illustrated. For instance, on the two cylinder, double-acting compressor with 90° cranks, a “galloping” effect due to acceleration of the unbalanced reciprocating parts is introduced once per revolution.

Two-stage compressors usually do not have exactly equal loading on all cylinder ends. In some cases, reciprocating compressors operate on two or more suction systems operating at different temperatures and at different pressures. Various arrangements to secure part-load operation such as lifting suction valves, opening clearance pockets, cutting in partial by-pass systems, etc., may introduce various degrees of unbalance. Most types of compressors are covered by a NEMA table in which each common application is assigned an application number and “Compressor Factor.” Figure 45 illustrates percent current pulsation for NEMA application No. 5 covering a single stage, two cylinder, double-acting compressor with 90° cranks, plotted against “Compressor Factor” “X” as the abscissa. This curve shows that with “X” values of 2.0 to 6.0, or above 12.0, the current pulsation will not exceed 66%.

### Flywheel effect

The required flywheel effect to limit current pulsation is proportional to the compressor factor “X” shown in this formula:

$$WK^2 = X \times Hz \times Pr \times G$$

$WK^2$  = Total flywheel effect in foot pounds squared  
 $X$  = Compressor factor  
 $Hz$  = Line frequency in CPS  
 $Pr$  = Synchronizing power  
 $G = 1.34 \times \frac{(100)^4}{rpm^4}$

Flywheel effect values calculated by the above formula and using compressor factors established by NEMA will satisfy the condition that the natural and forcing frequencies differ sufficiently to meet allowable pulsation.

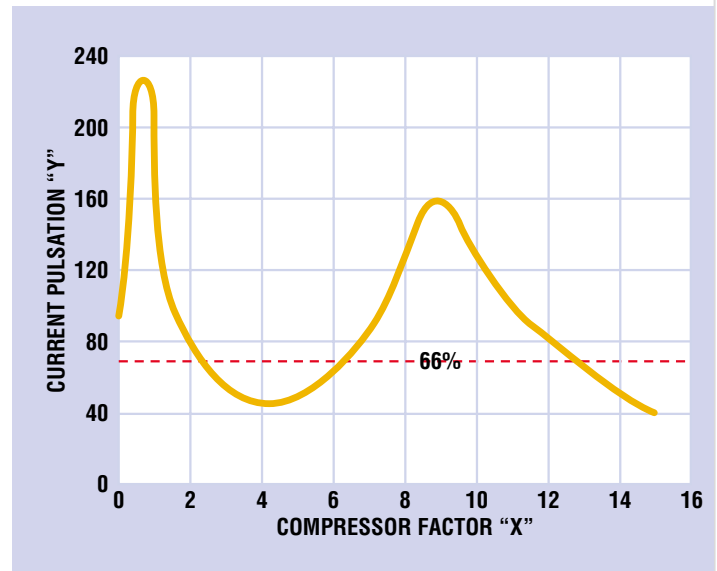

Figure 45 X-Y curve for determining flywheel requirements.

### Centrifugal compressors and vacuum pumps

Various types of centrifugal, positive displacement compressors are used to compress air or various gases or to serve as vacuum pumps. The Hytor, or water seal type, is frequently used as a vacuum pump in paper mills, and NEMA recommends special torque consideration. See Figure 46.

NEMA Recommended Torques for Compressors	Torques in % of Full-load Torque		
	Starting	Pull-in	Pull-out
Compressors, centrifugal - starting with:	30	40-60	150
a. Inlet or discharge valve closed	30	100	150
b. Inlet or discharge valve open			
Compressors, Fuller Company	60	60	150
a. Starting unloaded (by-pass open)	60	100	150
b. Starting loaded (by-pass closed)			
Compressors, Nash-Hytor - starting unloaded	40	60	150
Compressors, reciprocating - starting unloaded			
a. Air and gas	30	25	150
b. Ammonia (discharge pressure 100-250 psi)	30	40	150
c. Freon	30	40	150

Figure 46

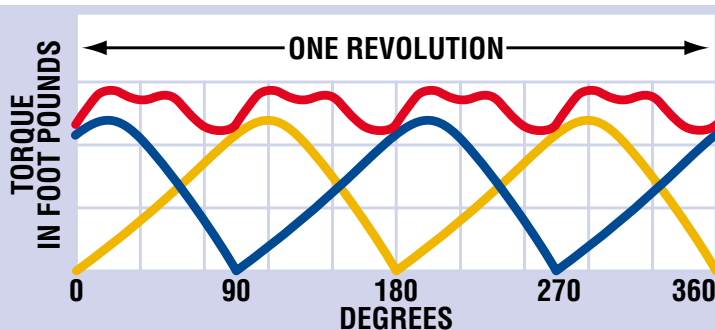

Figure 44  
Crank effort diagram for a two cylinder, double-acting compressor, or four cylinder, single-acting compressor.

# The ABC's of Synchronous Motors Applications

## Centrifugal fans, blowers, compressors, and exhausters

Centrifugal fans, blowers and compressors differ from reciprocating units in that the pressure developed is a function of the density of the air or gas handled, the speed of the impeller, and of restriction to flow. The gas is accelerated in passing through the rapidly rotating impeller, this velocity being converted into pressure in the volute casing surrounding the impeller.

Units operating at pressures above 30 psi are called compressors. For pressures above 100 psi, multi-stage compression is commonly used. These units are especially suited for high volume at low pressure. NEMA recommended torques are shown in Figure 47.

Many of these applications have substantially more than normal load WK2. The actual value should be taken into account in applying and designing motors for such loads. Care should also be taken in applying motors to fans normally handling hot gases. The load, when handling cold air, as in starting, will be substantially higher.

NEMA Recommended Torques	Torques in % of Full-load Torque		
	Starting	Pull-in	Pull-out
<b>Blower, Centrifugal –</b>			
Inlet or discharge valve closed	30	40-60	150
Inlet or discharge valve open	30	100	150
<b>Compressor, Centrifugal</b>			
Inlet or discharge valve closed	40	40-60	150
Inlet or discharge valve open	40	100	150
<b>Fan, Centrifugal (Except Sintering)</b>			
Inlet and discharge valve closed	30	40-60	150
Inlet and discharge valve open	30	100	150
<b>Fan, Sintering</b>			
Inlet gates open or closed	40	100	150
<b>Fan Propeller –</b>			
Discharge Open	30	100	150

Figure 47

Type	Specific Speed	% Torque at Shut-off
Radial-flow	500	45
	1000	50
	2000	60
	3000	70
Mixed-flow	5000	120
Axial-flow	10000	220

Figure 48

## Synchronous motors for centrifugal pumps

The term “centrifugal” may be applied to radial-flow, mixed-flow or axial-flow pumps. In all cases, energy is added to the flowing liquid by means of pressure differences created by vanes of a rotating impeller or propeller. The radial-flow pump discharges the liquid at right angles to the shaft, the mixed-flow discharges it at an angle, and the axial flow propels the liquid in an axial direction.

Hydraulically, the difference is fundamentally one of the “specific speed” used in the design. Mathematically, it is shown by this formula:

$$Ns = \sqrt{\frac{NQ}{H^{3/4}}}$$

- Ns = Specific speed
- N = rpm
- Q = gpm
- H = Total head in feet where Q and H correspond to conditions at which maximum efficiency is obtained

These differences are important in the application of synchronous motors, as can be seen in Figure 48.

The important factor is the torque required at full speed and closed discharge. In the radial-flow centrifugal pump, this is usually about 55% of full load torque. In the axial-flow it may reach 220%. Obviously, no attempt should be made to synchronize a motor driving a mixed-flow or axial-flow pump under shut-off conditions. However, the inertia of the water column alone simulates a partially closed discharge in case of attempted rapid acceleration, as in the case of pulling into step. See Figure 49.

The pull-in torques given above are inadequate where mixed-flow or axial-flow pumps are concerned. In some cases it is possible to start these pumps with partially empty casings, thus reducing pull-in requirements.

On vertical pump motors, additional thrust capacity is usually required where rigid couplings or hollow shafts are used, and the motor thrust bearing must support all rotating parts plus hydraulic load. Where thrust loads are unusually high, the break-away or starting torque required may be considerably in excess of values in Figure 49. In such cases, hydraulic lift bearing should be considered.

# The ABC's of Synchronous Motors

## Application

### Synchronous motors for crushers, grinders, and mills

Crushing, grinding or pulverizing is a necessary step in separation of metal from ore, preparation of crushed rock for the construction industry, preparation of agricultural limestone, and manufacture of portland cement.

Primary crushers, usually jaw, gyratory or hammermill type, are fed the rock or ore directly after blasting. The material next goes to the secondary crusher where reduction to about 1/2" may be accomplished. Secondary mills may be gyratory, cone, hammermill, or roll type.

Rod mills may also be used as secondary grinders. A rod mill consists of a steel shell lined with wear-resistant material and rotated about a horizontal cylinder axis. The mill uses steel rods 2 to 5 inches in diameter running the length of the mill. As the mill rotates, the tumbling action of the rods causes grinding.

Final grinding, possibly down to a material which will pass through a 200 mesh screen or finer, is usually done in a ball mill. This is similar to a rod mill except that steel balls tumble over the material to be crushed. Autogenous mills use the crushed rock to grind itself to powder. See Figure 50 for NEMA recommended torques for the various types of mills.

### Synchronous motors for pulp and paper mills

One of the largest power consuming industries is that of processing wood and wood products in the manufacture of paper and pulp.

Although alternative fibers may be used in relatively small quantities in the manufacture of pulp and paper, by far the largest source is wood. Paper may be made either by the groundwood or chemical process. The application table and recommended NEMA torques shown in Figure 51 cover the usual synchronous motor applications in paper mills, most of which are common to both processes.

Paper mills are large users of synchronous motors for pumps, refiners, chippers and other equipment.

NEMA Recommended Torques for Pumps	Torques in % of Full-load Torque		
	Starting	Pull-in	Pull-out
<b>Pumps, axial flow, adjustable blade – starting with:</b>			
a. Casing dry	5-40	15	150
b. Casing filled, blades feathered	5-40	40	150
<b>Pumps, axial flow, fixed blade – starting with:</b>			
a. Casing dry	5-40	15	150
b. Casing filled, discharge closed	5-40	175-250	150
c. Casing filled, discharge open	5-40	100	150
<b>Pumps, centrifugal, Francis impeller – starting with:</b>			
a. Casing dry	5-40	15	150
b. Casing filled, discharge closed	5-40	60-80	150
c. Casing filled, discharge open	5-40	100	150
<b>Pumps, centrifugal, radial impeller – starting with:</b>			
a. Casing dry	5-40	15	150
b. Casing filled, discharge closed	5-40	40-60	150
c. Casing filled, discharge open	5-40	100	150
<b>Pumps, mixed flow - starting with:</b>			
a. Casing dry	5-40	15	150
b. Casing filled, discharge closed	5-40	82-125	150
c. Casing filled, discharge open	5-40	100	150
<b>Pumps, reciprocating - starting with:</b>			
a. Cylinders dry	40	30	150
b. By-pass open	40	40	150
c. No by-pass (three cylinder)	150	100	150

Figure 49

Application	Torques in % of Full-load Torque		
	Starting	Pull-in	Pull-out
Gyratory (unloaded)	100	100	250
Cone (unloaded)	100	100	250
Hammermill (unloaded)	100	80	250
Roll crusher (unloaded)	150	100	250
Rod mill - ore	160	120	175
Ball mill - ore	150	110	175
Ball mill - rock or coal	150	110	175

Figure 50

NEMA Recommended Torques	Torques in % of Full-load Torque		
	Starting	Pull-in	Pull-out
Refiners (unloaded)	50	50-100	150
Conical (Jordan) disc	50	50	150
Chippers - empty (1)	60	50	250
Grinders (unloaded)			
Magazine	50	40	150
Pocket (unloaded)	40	30	150
Vacuum pumps (Hytor)	60	100	150

(1) These are high-inertia loads and motor torque requirements can not be determined from load value alone. WK<sup>2</sup> values must be known to permit proper motor application.

Figure 51



# The ABC's of Synchronous Motors

## Speed

### Adjustable speed

Some applications have varying requirements. For example, a process may at times require more water or air. The pump or compressor and motor are sized for the maximum, and a throttle is used to reduce the flow. This does not reduce the power used substantially, since the reduced quantity is offset by the greater head caused by the throttle. See Figure 52.

To overcome this, a slip clutch (eddy current drive) is sometimes used. Electric Machinery manufactures a magnetic drive for this use. Here the motor runs at rated speed and the magnetic drive slips, allowing the load to run at a lower speed. At the lower speed the output and the torque required are reduced. Although the torque is reduced, the motor still runs at rated speed, so the HP is down in proportion to the torque. There is some slip loss in the slip clutch. This type of variable speed drive is declining in use.

### Adjustable speed with synchronous motors

When one thinks of synchronous motors, the idea of a motor running at an absolutely constant speed comes to mind. While this mental picture is correct it is so only because the power line frequency is a constant, and synchronous motors are “locked in” to the line frequency.

As technology has advanced over the latter third of the twentieth century, the ability to change the frequency of the incoming line power — and thus, to control the speed of “constant speed” motors — has become a reality. This has led to adjustable speed drives for pumps, fans, compressors and other loads, yielding higher operational efficiencies, lower wear rates, softer starting, lower starting currents, and even quieter operation as machines run at reduced speeds. See Figure 54 and compare it with Figure 53 to see potential efficiency improvements with adjustable frequency vs. eddy current drive.

A “tool” which has come out of development efforts and is finding application is the Load Commutated Inverter, or LCI. The LCI is reminiscent of the “incher,” an array of six contactors used to switch direct current in sequence, first positive polarity and then negative, to the three phases of a normally excited synchronous motor, thus enabling it to slowly “inch” its load around to position it for maintenance reasons. The difference is that the LCI can do this job at a wide variety of frequencies, including frequencies higher than line frequency, thus even enabling supersynchronous (>synchronous speed) operation. The incher was limited to one slow speed.

The LCI drive (also commonly referred to as “VFD,” or variable frequency drive) consists of an incoming section which supplies direct current via a current-smoothing choke to an inverter section. The inverter supplies dc power to the synchronous motor by switching it between phases at the desired frequency corresponding to speed. Because of the functions being accomplished, the inverter and motor together are sometimes referred to as a brushless dc motor. Refer to Figure 55.

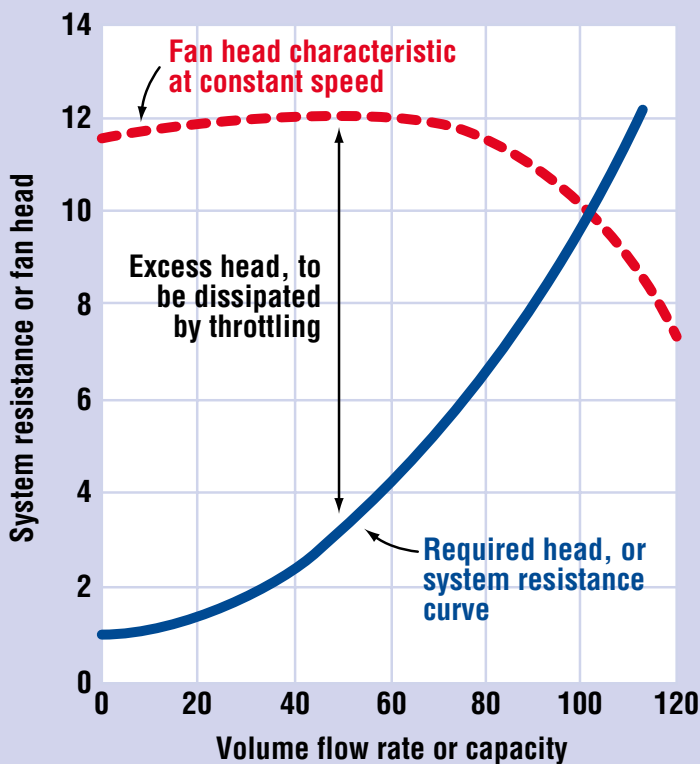
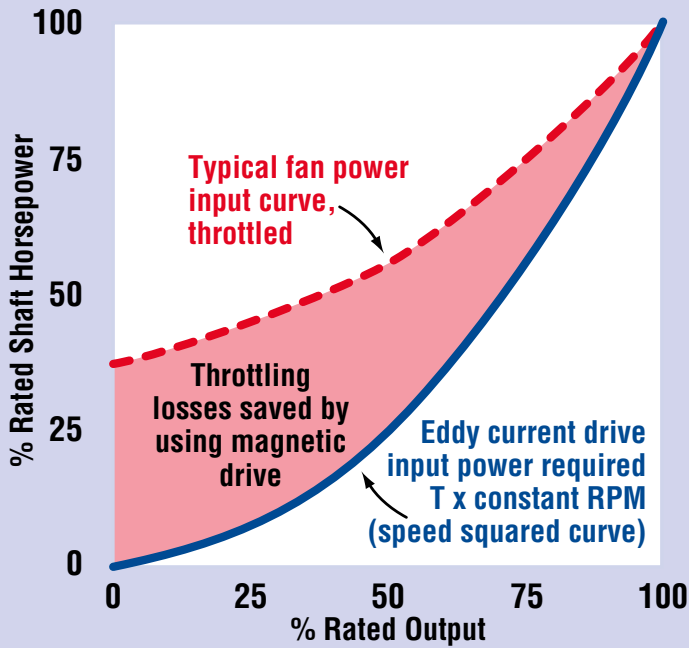

Figure 52 System resistance and fan head characteristic.



# The ABC's of Synchronous Motors

## Speed



**Figure 53** Power into eddy current drive is product of torque required and constant input rpm. With an unthrottled fan or pump, the torque requirement is nearly a direct function of speed squared, thus, input power varies as the output speed squared.

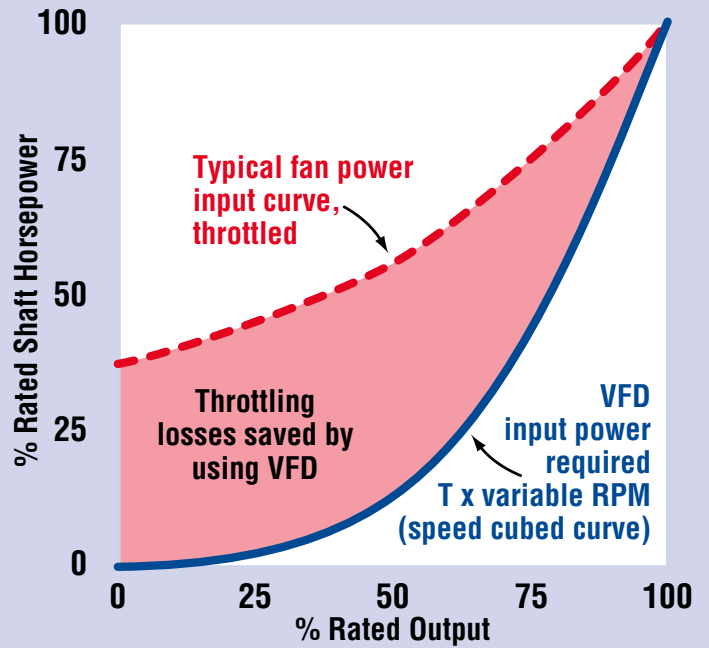

**Figure 54** Power into variable frequency drive is the product of the torque required and the output rpm. With a load as in Figure 53, the input varies as the speed cubed.

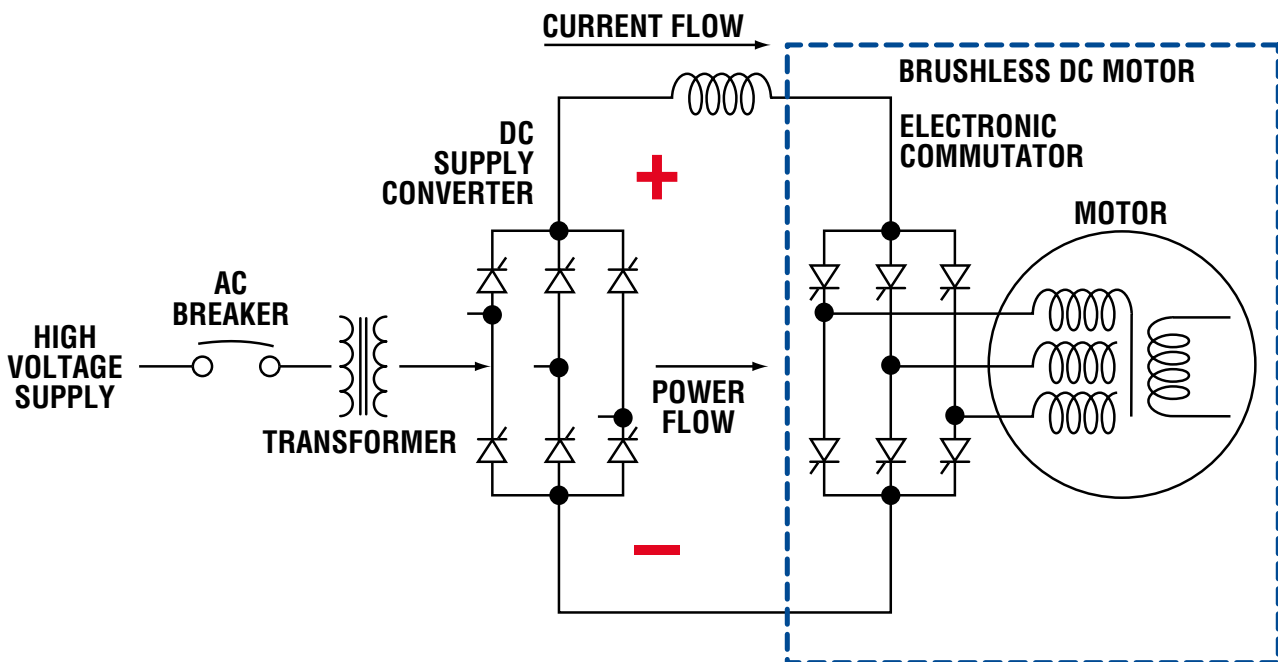

**Figure 55** Load commutated variable frequency drive (6-pulse).



## The ABC's of Synchronous Motors Speed

As with any thyristor circuit, once a thyristor is turned on, the current must be reduced to zero before the thyristor returns to the non-conducting state. With an excited synchronous motor as the load, the commutation is accomplished using the open circuited winding to generate opposing voltages in the machine. (Figures 56 and 57.) To provide reliable operation at low speeds, encoders are sometimes used to indicate the instantaneous position of the rotor to the control so that succeeding thyristors can be turned on at the proper instant. Variations in technologies also exist which use no encoders, but work by sensing the back voltages from the machine. Whichever method is used, a rotating magnetic field is established.

The simplest type of LCI uses a six-step approach. Refer to Figure 59 and note the progression of the resultant vector as dc is applied in sequence and at alternating polarity to each phase of the machine. The vector, representing the magnetic field, progresses around the stator in one complete cycle.

The six-step approach, while the simplest, is not the smoothest. The pulsations associated with the finite progression of magnetic fields around the stator are reflected in torque pulsations and magnetic noise. Care must be exercised to avoid critical frequencies in the motor shaft and other elements which could respond to pulsations set up by the inverter action. In some cases, special couplings must be applied to avoid premature failures. The six-step approach is commonly used for horsepower in the 500-2500 range, sometimes up to 6000 HP. Refer to Figure 60.

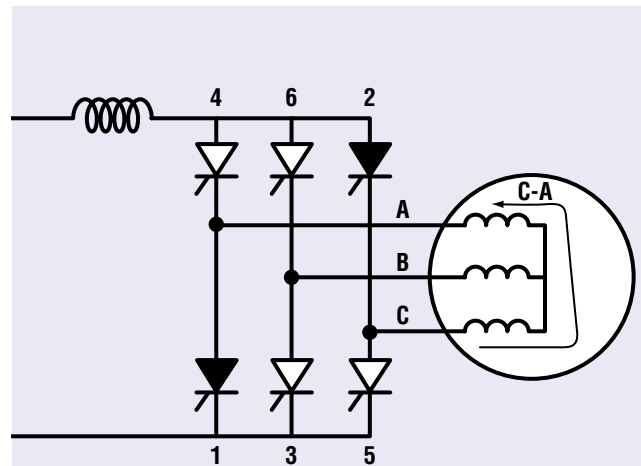

Figure 56 Load Current Path (C-A)

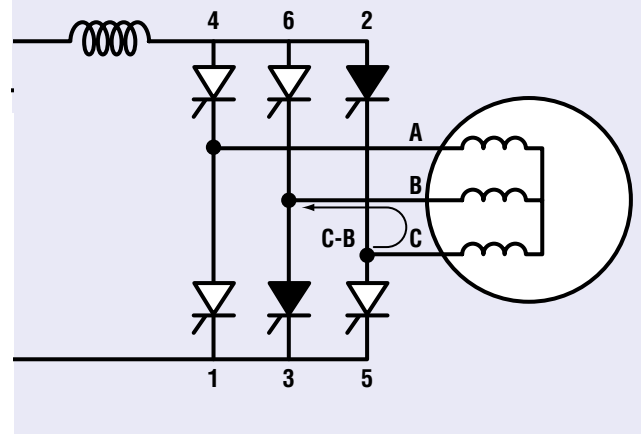
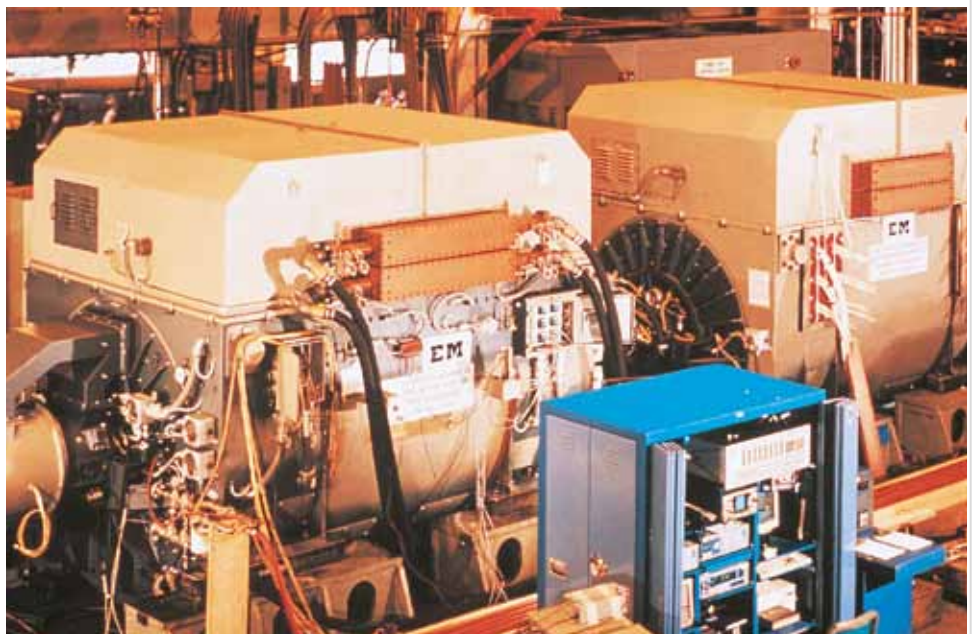

Figure 57 Load Current Path (C-B)

A smoother-acting system can be assembled by taking advantage of the 30° difference between the secondary voltages in wye and delta connected transformers. Using this motor and transformer combination, a twelve-step inverter can be applied.

**Figure 58** Back-to-back test of 2-14200 HP 3200 rpm 2 pole synchronous motors for VFD application. The shaft extensions are coupled together, and with their respective VFDs one operates as a motor and the other operates as a generator, achieving essentially full load operation of each machine. In this type of test, the local utility must only make up the losses of the machines and VFDs.



# The ABC's of Synchronous Motors Speed

In Figure 61, the progression of the vector can be followed as above, but the steps now are at 30° intervals rather than at 60°, as in the six-step inverter. Another significant advantage is a reduction in harmonics imposed on the incoming line as well as torque harmonics to the load. Figures 62 and 63 further illustrate the differences between six- and twelve-step inverter actions. The fifth, seventh, seventeenth, nineteenth, and many higher order harmonics cancel in the wye and delta secondaries; they do not appear in the incoming power to the twelve step converter. The result is smoother operation, fewer concerns about torsional stresses, quieter running, lower harmonics on the incoming line, and a reduced output requirement from each thyristor bridge.

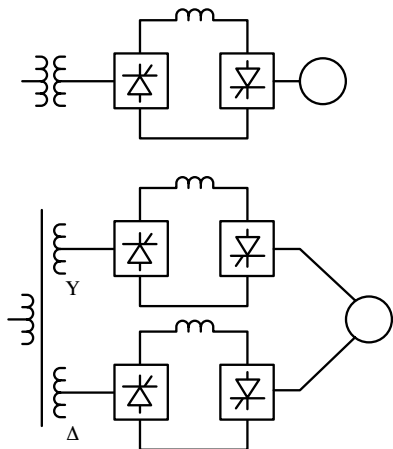

**Figure 60** Top: 6 Pulse single winding.  
Bottom: 12 Pulse dual winding.

While two transformers could be used to feed the twelve-step converter, a three-winding transformer is frequently used (note in Figure 60). This could be done with transformers between the inverter and the motor, but the motor is frequently wound with a dual winding to isolate the outputs of the two inverter sections. The two separate windings are shifted 30 electrical degrees. Each part of the motor stator actually sees a six-step progression, but the rotor sees the twelve-step sum of the two inputs to the machine. The twelve-step approach is typically used for horsepower of 2000 and larger, even up to 50,000.

Current-limiting functions are often employed during starting, keeping currents to values considerably under normal locked rotor values. The current limit is adjustable and is set as a function of the amount of torque required. Available starting torque, when operating with an LCI, is more like the maximum operating torque of the motor, since it is

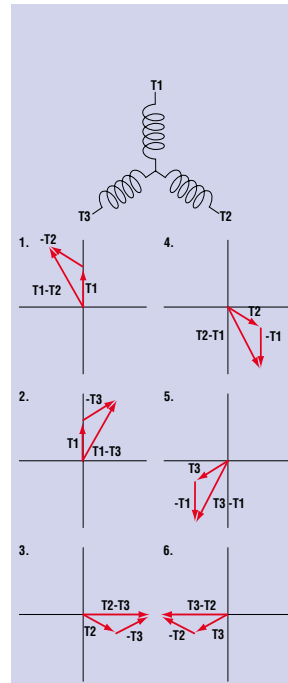

**Figure 59** Single winding 6 pulse.

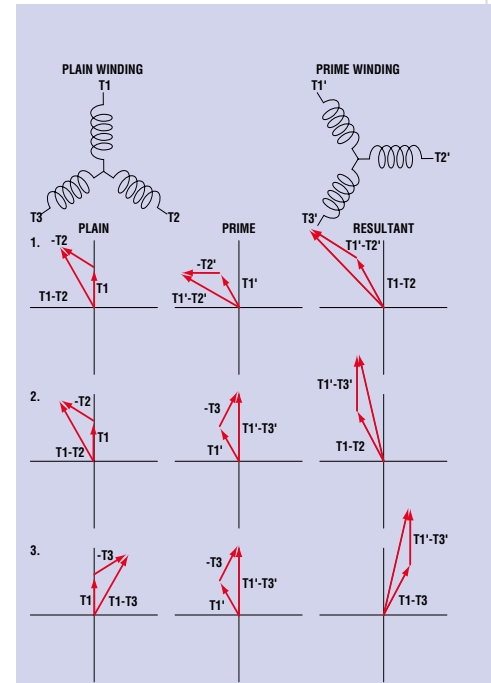

**Figure 61** Single winding 12 pulse. (Only 3 of the 12 pulses are shown)

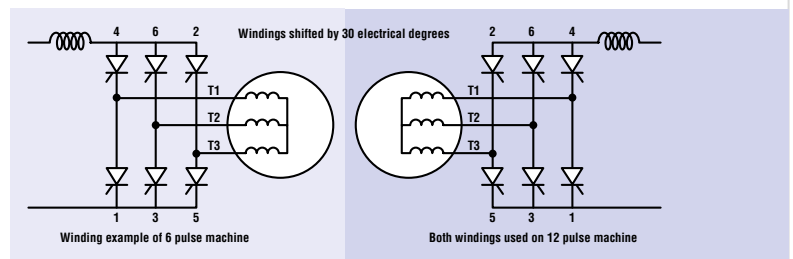

Degrees	SCR						Current In	Current Out	SCR						Current In	Current Out	Comments
	1	2	3	4	5	6			1	2	3	4	5	6			
<b>Single Winding</b>																	
60			X	X			T1	T2									
120				X	X		T1	T3									SCR's
180					X	X	T2	T3									Switch Every
240	X					X	T2	T1									60°
300	X	X					T3	T1									
360			X	X			T3	T2									
<b>12 Pulse Dual Winding</b>																	
30			X	X			T1	T2			X	X			T1'	T2'	
60			X	X			T1	T2			X	X			T1'	T3'	
90			X	X			T1	T2			X	X			T1'	T3'	
120				X	X		T1	T3				X	X		T2'	T3'	
150				X	X		T2	T3				X	X		T2'	T3'	SCR's
180				X	X		T2	T3	X				X		T2'	T1'	Switch Every
210	X				X		T2	T1	X						T2'	T1'	30°
240	X				X		T2	T1	X	X					T3'	T1'	
270	X	X					T3	T1	X	X					T3'	T1'	
300	X	X					T3	T1		X	X				T3'	T2'	
330		X	X				T3	T2		X	X				T3'	T2'	
360			X	X			T3	T2			X	X			T1'	T2'	

**Figure 62** SCR firing sequence for 6 pulse and 12 pulse drive.

# The ABC's of Synchronous Motors

## Speed

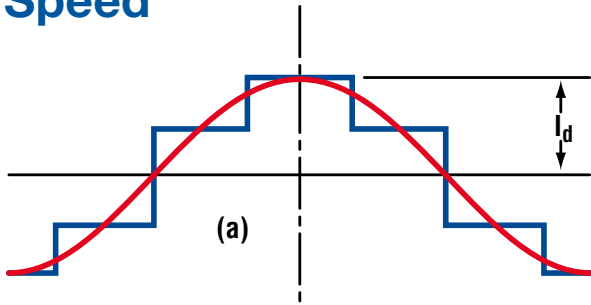

### 6-Pulse Converter With Delta/WYE Transformer

Fourier Series:

$$i = \frac{2\sqrt{3}}{\pi} I_d [\cos \theta + \gamma_5 \cos 5\theta - \gamma_7 \cos 7\theta - \gamma_{11} \cos 11\theta + \gamma_{13} \cos 13\theta + \gamma_{17} \cos 17\theta - \gamma_{19} \cos 19\theta -]$$

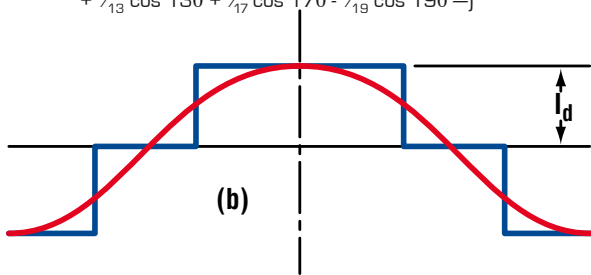

### 6-Pulse Converter With Delta/Delta Transformer

Fourier Series:

$$i = \frac{2\sqrt{3}}{\pi} I_d [\cos \theta - \gamma_5 \cos 5\theta + \gamma_7 \cos 7\theta - \gamma_{11} \cos 11\theta + \gamma_{13} \cos 13\theta - \gamma_{17} \cos 17\theta + \gamma_{19} \cos 19\theta -]$$

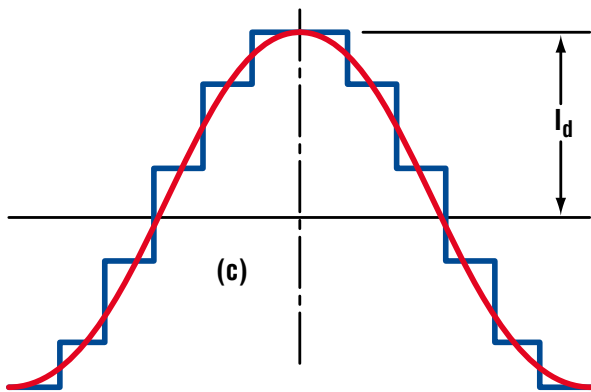

### Current in Delta/Delta and Delta/WYE Transformers

Fourier Series:

$$I_{total} = \frac{2\sqrt{3}}{\pi} I_d [\cos \theta - \gamma_{11} \cos 11\theta + \gamma_{13} \cos 13\theta - \gamma_{23} \cos 23\theta + \gamma_{25} \cos 25\theta -]$$

**Figure 63** Sine wave simulation of VFD output.

synchronized with the very low frequency source. Greater starting torques may be available at the same time that lower starting currents are demanded when compared with across-the-line starting. Reduced speed operation is controlled at a constant volts-per-hertz basis so the magnetic structure is not saturated.

Occasionally, a by-pass contactor or circuit breaker will be supplied to connect the line directly to the machine. This will affect the cost of the installation, but it may also be desired by the user as a backup system. It is also possible to start or operate multiple machines while using only one LCI. For example, there may be two pumps; one may be operating via the LCI, but its capacity has been exceeded by the demand. This machine can be transferred to across-the-line operation via the by-pass contactor and the LCI transferred to the second machine, which it can bring up to operating speed, increasing the total capacity in a very smooth and bumpless manner. Refer to Figure 64.

Occasionally, it will be desired that voltage will be increased to rated level at speeds over 80% (of line frequency rating). For this condition, the motor is built with enough iron so that magnetic saturation does not become problematic. The result is that the machine can run without a power factor penalty. Low voltage means delayed firing angles in the front (input) end of the converter, and that translates into a low power factor. Since it is common for large machines (forced draft and induced draft fans) to run at speeds between 80% and 100%, it is desirable to operate at 100% voltage and realize the benefit of the improved power factor (as seen by the line) available from 80% to 100% speed.

While unity or leading power factors are generally associated with synchronous motors, this feature does not hold true when the motor is operated through an LCI. The motor will be operating at a leading power factor, but the line does not see the motor; it sees the input section of the LCI, and that is always a lagging power factor load. The lower the speed (voltage) the more lagging the power factor, and the best power factor is still only about 90% when output voltage to the motor is at maximum.

Cooling the machine may be by use of an integral fan if the load is variable torque and is not expected to operate at speeds below about 50% for extended periods. If a constant torque load is being driven, however, and particularly if the speed will be less than 50% rated, external cooling fans must be employed. Often, the motor will be oversized to lessen the effects of reduced cooling at lower speeds.

Sometimes present in the output supplied to the motor from the LCI are common mode voltages which may impose higher-than-usual stresses to ground from the machine winding. Accordingly, it is necessary to provide groundwall insulation with 1.3 to 1.8 times the normal dielectric strength compared to ordinary machines when the unit is to be operated from an inverter.



# The ABC's of Synchronous Motors Speed

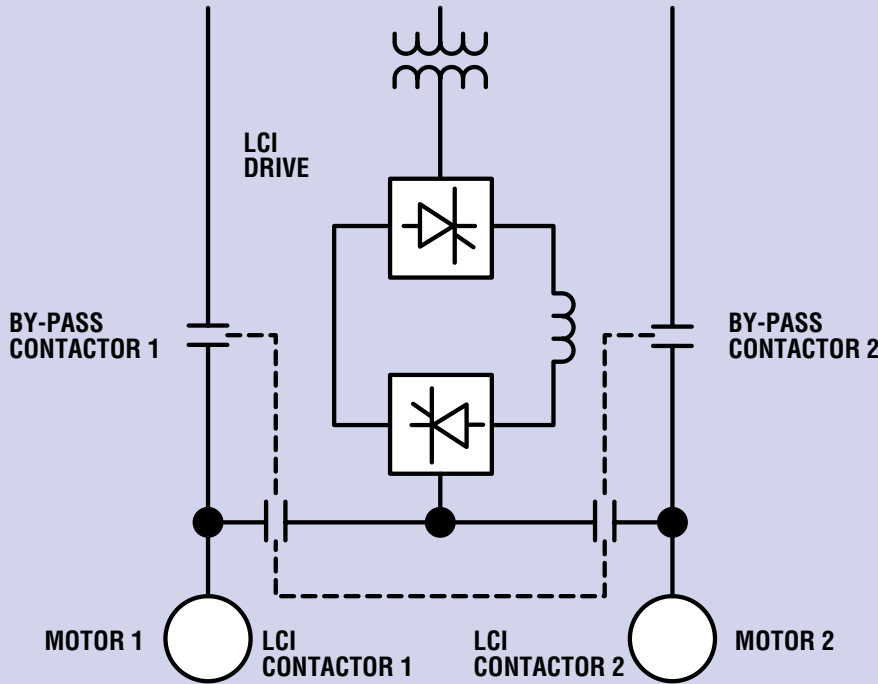

**Figure 64**  
*By-Pass and LCI  
Contactor are  
interlocked to be  
mutually exclusive.*

the speed and loads for centrifugal pumps and fans are related to the cube of the speed. Realizing this, it soon becomes apparent that a small increase in speed results in much larger changes in centrifugal stresses and in loading; thus, these expectations must be known by the machine designer so that proper capabilities can be incorporated into the design. Critical frequencies, which, might otherwise occur at speeds only slightly above normal synchronous speed, could also be avoided.

The exciter design must differ from conventional designs in that conventional exciters extract energy from the rotating shaft, whereas, that source would be such a variable factor — even approaching zero at very low speeds — the energy must be transmitted to the rotor by another means. Exciter designs for these motors use three-phase ac excitation on the stator, applied so the rotating field is counter-rotating to the rotor. In a very real sense, it is a rotating transformer with an air gap in the magnetic circuit, and all of the power developed in the rotor comes from the excitation source. The exciter may or may not have the same number of poles as the motor; however, the frequency in the rotor circuit is not critical, since it is rectified.

An advantage of the LCI drive which has not been discussed is the ability to run at supersynchronous speed (higher than the synchronous speed of a machine with the same number of poles when connected to the line). If this kind of operation is planned, it must be kept in mind that centrifugal forces are a function of the square of

We have seen that the motors used with inverters are much the same as those which are applied only at line voltages and frequencies; the major differences being in two-winding stators for the twelve-step inverter applications, possible heavier ground-wall insulation, cooling, and three phase exciter stator windings, plus torsional considerations and, possibly, provisions for supersynchronous operation which affects the mechanical facets of the design as well as the electrical. However, these are but refinements to the machine to adapt it to a special application.

Advances in technology, bringing about such equipment as the Load Commutated Inverter, continue to open new doors of opportunity for application of that old, reliable workhorse of industry, the Synchronous Motor.

Synchronous motors fill an important place in industry. They are usually associated with loads of major importance. A corresponding degree of care in their applications is well advised and worth the extra effort.



## The ABC's of Synchronous Motors

### About the Authors



#### Gerry Oscarson

Now deceased, Gerry Oscarson was the original author of this special issue of the *EM Synchronizer*. He held Electrical Engineering degrees from the University of Minnesota. Specializing in electric power apparatus, Mr. Oscarson was directly associated with the industrial application of motors, generators, and controls. For many years, he was Chief Application Engineer of the Electric Machinery Manufacturing Company. The ABC series of EM Synchronizers are Gerry's work. These remain as standard references for industrial plants around the world, and are often used as texts by engineering schools.



#### Jack Imbertson

Jack Imbertson holds an Electrical Engineering degree from the University of Minnesota. While at EM, he held the positions of Design Engineer, Programmer, Manager of Synchronous Machines, and Manager of Turbo Generators. He has been active in IEEE and was a past chairman of the IAS section. He also served as a member of the ANSI C50 standards committee on synchronous machines.

Since retirement, he has taught electro-mechanics at the University of Minnesota and does some consulting.



#### Ben Imbertson

Ben Imbertson holds a Bachelors degree in Electrical Engineering from the University of Minnesota and is a registered Professional Engineer. While at EM, he worked as a Control Design Engineer, Control Engineering Section Head, and Principal Engineer-Control Products.

His EM experience included applications in synchronous and induction motor control, generator control, as well as adjustable-speed drives. His post EM experience has been in similar areas.

Ben's writing has appeared in several EM publications including *the Synchronizer*, "The ABC's of Motor Control."



#### Steve Moll

Steve Moll is presently Senior Marketing Representative with Electric Machinery. He holds a Bachelor of Electrical Engineering degree from the University of Minnesota.

His experience at EM includes Senior Design Engineer where he worked with motor and generator controls, as well as high voltage switchgear and controls for gas turbine driven generators. In his present position, his area of specialty is application and marketing of 2-pole turbine driven generators. He has significant experience with synchronous and induction motors as well.

Several of Steve's articles have appeared in trade as well as company publications.





WEG Electric Corp. offers the following products, and more! With a full range of IEC/NEMA Global Certifications and a full line of products, WEG can supply the right solution for your needs anywhere in the world. To learn more about WEG's products and solutions or to locate a Distributor near you, please call **1-800-ASK-4WEG** or visit **www.weg.net/us**.

**Low Voltage Motors,**

**Single and 3-Phase, 1/8 – 700HP**

- General Purpose Motors
- Explosion Proof Motors
- Crusher Duty Motors
- IEC Tru-Metric Motors
- Pump Motors including JP/JM
- P-Base Pump Motors
- Oil Well Pumping Motors
- Pool & Spa Motors
- Brake Motors
- Compressor Duty Motors
- Farm Duty Motors
- Poultry Fan Motors
- Auger Drive Motors
- IEEE 841 Motors
- Stainless Steel Wash Down Motors
- Saw Arbor Motors
- Cooling Tower Motors
- Commercial HVAC Motors
- Pad Mounted Motors
- Vector Duty Motors

**Large Electric Motors**

- Low Voltage 3-phase motors up to 2,500HP
- Motors up to 150,000HP and 14,400 V
- Wound Rotor Systems (including starters) up to 70,000HP and 13,200V
- Synchronous Motors up to 70,000HP and 13,200V
- Explosion proof motors (Ex-d) up to 1,500kW and 11kV
- Ex-n, Ex-e, Ex-p motors

**Variable Frequency Drives**

- Low Voltage 1/4 to 2500HP, 230V – 480V
- Medium Voltage 500-8000HP
- Multi-pump systems
- NEMA 4X
- Dynamic braking resistors
- Line and load reactors
- Plug and play technology
- Network communications: Profibus-DP, DeviceNet, Modbus-RTU
- PLC functions integrated
- Complete line of options and accessories

**Soft Starters**

- 3-1500HP
- Oriented start-up
- Built-in bypass contactor
- Universal source voltage (230-575V, 50/60Hz)
- Network communications: Profibus-DP, DeviceNet, Modbus-RTU
- Complete Line of options and accessories
- MV Soft-starter 3.3kV, 4.16kV: up to 3500HP, Withdrawable Power Stacks, & 8x PT100 Temperature monitoring

**Controls**

- Mini – Contactors
- IEC Contactors
- Thermal Overload Relays
- Manual Motor Protectors
- Molded Case Circuit Breakers
- Smart Relays
- Enclosed Starters: combination & non-combination,
- Pushbuttons & Pilot Lights
- Timing & Motor Protection Relays
- Terminal Blocks

**Custom Panels**

- Custom configured to your specification.
- NEMA 1, 12, 3R, 4 and 4X cabinets
- Quick delivery of preconfigured drives and soft starters
- UL 508 certified
- Low Voltage (230-460)
- Made in the U.S.A.

**Generators**

- Brushless Synchronous Generators for diesel gensets up to 4,200kVA
- Hydro-generators up to 25,000kVA
- Turbo-generators up to 62,500kVA

**Power Transformers**

- Built and engineered in North America
- Voltages < 500kV
- Ratings 5-300MVA
- Station class, oil filled, round core, copper windings
- Special configurations and designs available!
- Ask your WEG Sales Representative for details.
- Designed, built, and engineered to ANSI standards.

**Custom Solution Package Sales**

- WEG can package any of its products for ease of sale! Enjoy a single point of contact for the entire package of products and assistance from quote through after-sales support. Ask your WEG Sales Representative for details.

**Magnetic Drives**

- Ratings range from 300-1800 rpm and 200-2700 HP. Simple air-cooled design requires no auxiliary cooling and are available in horizontal and vertical constructions. No torque pulsations or harmonic pollution eliminates the need of filters. Suitable for pump and fan applications by matching equipment speed to meet flow demands.



Electric Machinery  
800 Central Avenue NE  
Minneapolis, Minnesota 55413  
United States  
Tel: +1 612 378 8000  
Fax: +1 612 378 8051  
[www.electricmachinery.com](http://www.electricmachinery.com)

Please contact your authorized distributor:

