

# Screening for Maximum Accuracy

Presented By: George Schlemmer



---

**QUARRY  
ACADEMY**

**LIGHTEN UP!**

# Today's Agenda

- Screening to promote a safe, cost efficient operation.
  - Value Chain Synopsis: The critical link... a golf course green.
- Topics covered:
  - Screens in the “Value Chain”.
  - Screening, media and accuracy.
  - Review of screening theories.
  - Selection criteria.
  - Duties and performance.

# Definition of Screening

- A mechanical process which stratifies (divides) particles according to size. The media (screening surface) opening then accepts or rejects the particles.

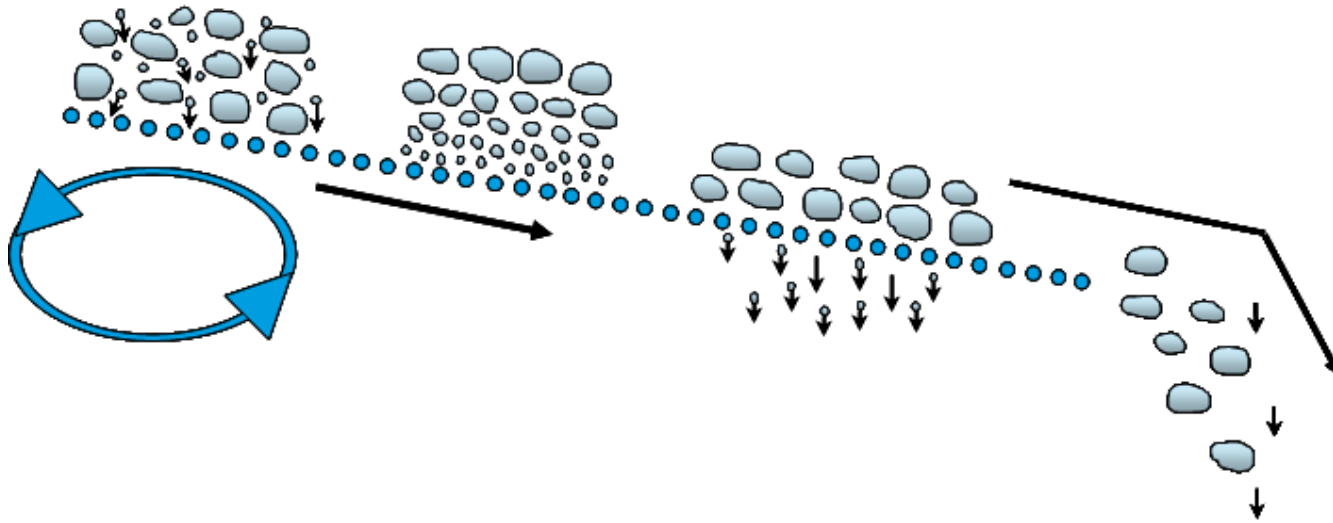

- Take home message: Size control, the process of separating solids into two or more products on the basis of their size.

# Definition of a Screen

- A screen is a device which separates a mix of particles into two or more groups depending on size.
- Where do we need sizing screens?
  - Decrease the load on other processes, like crushing.
  - Ensure a correct particle size for further processing or product stock piles.
- Take home message: Send the “Gold” to the sell pile, not recirculating through a circuit.

# Definition of Screen Media / Surface

- A screening medium with predetermined openings used to classify (size) two fractions of a feed material. Typically aggregate (sand, gravel, all stone types) whereas a top size product is retained (overs) and a through (fines) product is passed.
- **Clear opening** is the actual measured opening between two wires, such as in the case of wire cloth media.
- **Mesh** is defined as the number of openings per linear inch.

## The Definition of Mesh

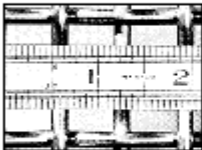

Mesh is defined as the number of openings per linear inch (primarily woven wire cloth or other synthetics). To count mesh, start from the center of one wire and count the number of openings to a point one inch in distance.

# All Three Together Equal the Fundamental Basics of Screening

## Throughput along the length of a screen

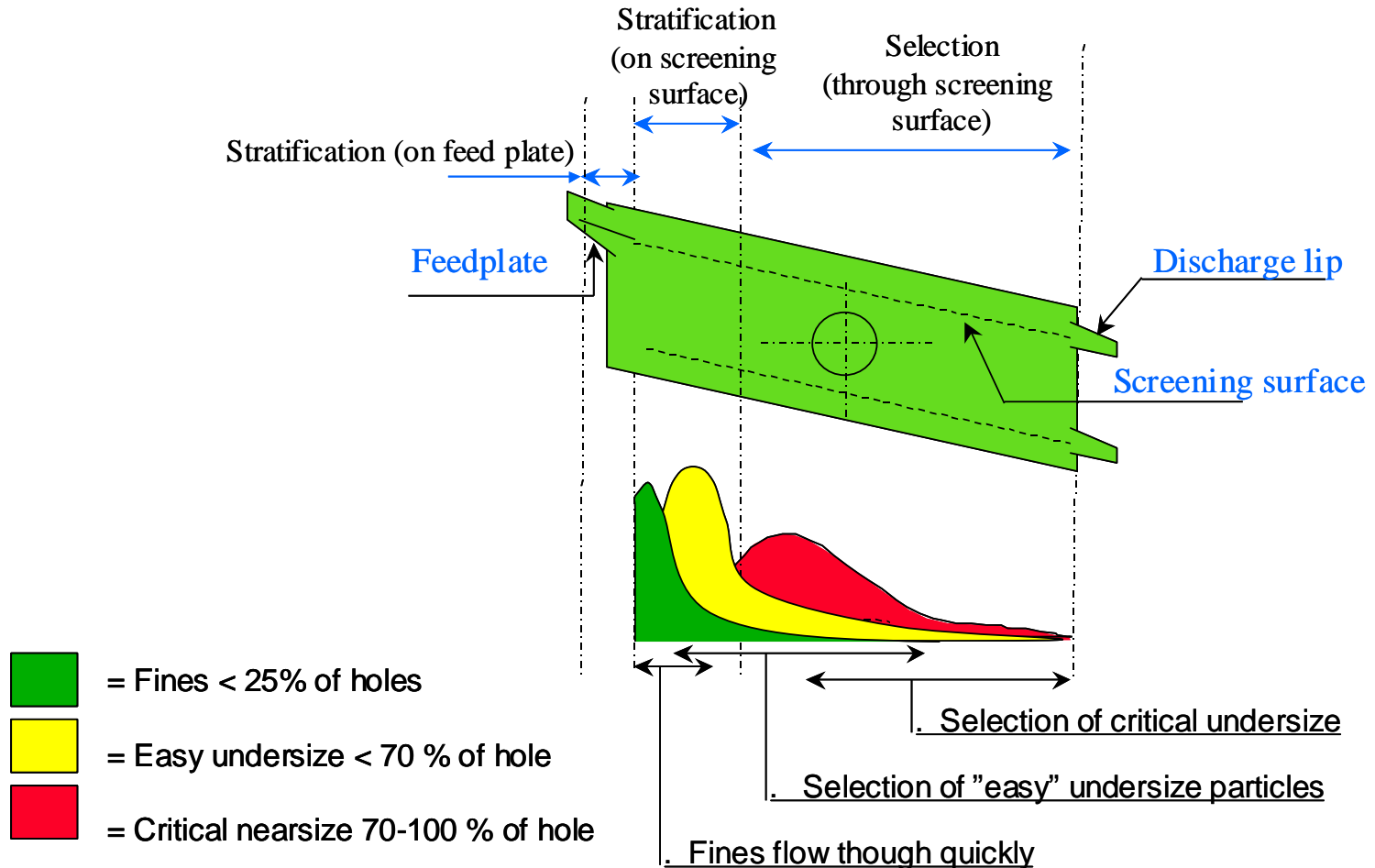



# Screening Throughput in Practice



Throughput: The quantity or amount of raw material processed within a given time.

# Screening Theory

The performance of a screen will revert back to five main parameters:

- Motion
  - Incline (Circular): Speed/RPM, stroke/throw and direction of rotation.
  - Horizontal (Elliptical or straight line): Speed/RPM, length of stroke/throw, throw angle (Ex. 45° line of action) and direction of rotation.
- Install angle of the unit.
- Screening media and available open area.
- Carrying capacity of the screen.
- Material characteristics (Dry, damp, wet, sticky, etc).
- Take home message: All are related and effect the performance of a screen.



# Conventional Screening - Stratification

This is Conventional Screening –  
it is based on stratification

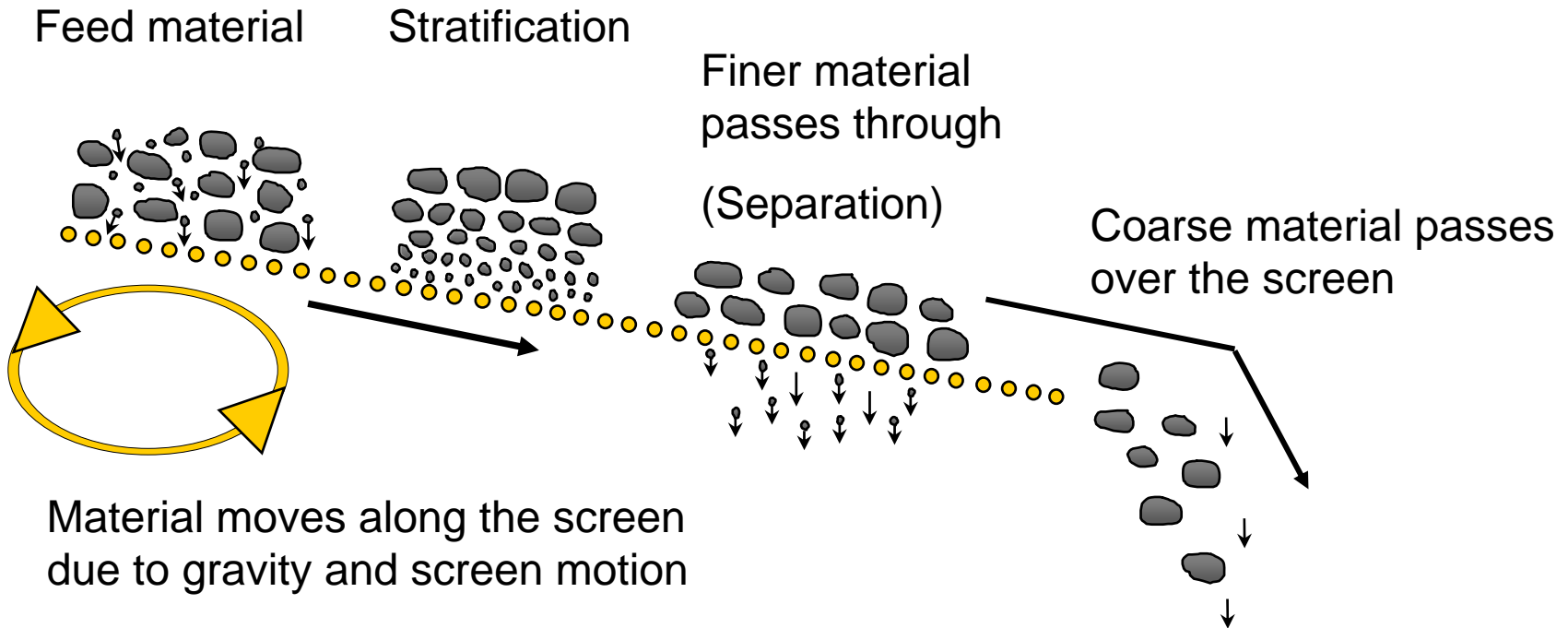

# Free-Fall Screening

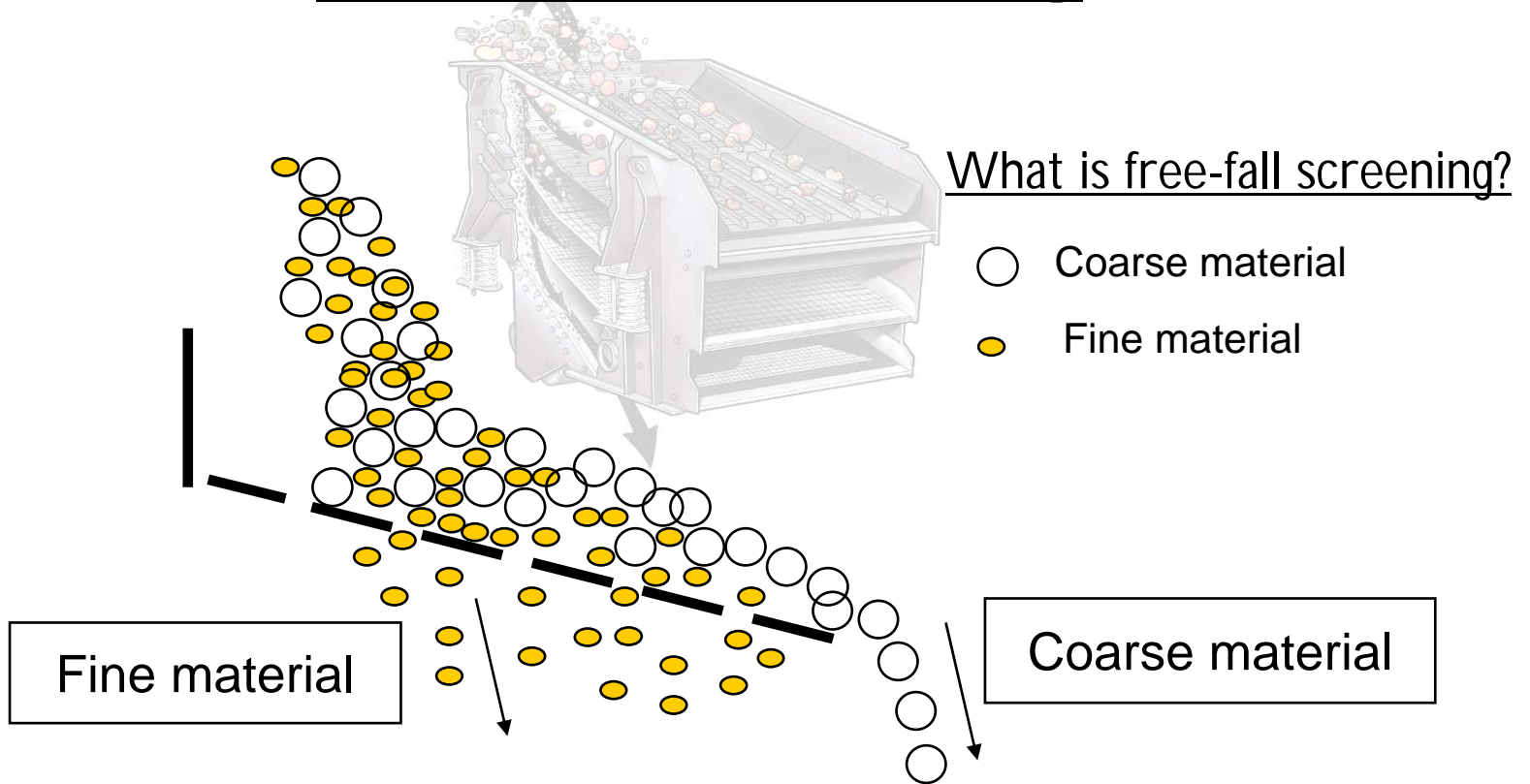

- Free-fall screening is based on the principle of free-fall of the material through and over the deck. I.e. No particle layer will build up on the screen deck.
- Optimal free-fall screening demands at least 70 % of the feed through the deck. I.e. High % of fines in the feed, high capacity.

# Types of Vibrating Screens



Incline



High Frequency



Horizontal



Scalper



Differential Deck



Roller Screen = non-vibrating

# Vibrating Screen Components

## Terms

1. Screen body
2. Media
3. Drive: Motor(s) with v-belts or cardan shaft kit
4. Mechanism/Exciter
5. Spring support assemblies

Options not shown:

- Dust encapsulation
- Spray bar system
- Galvanized
- Support structure...

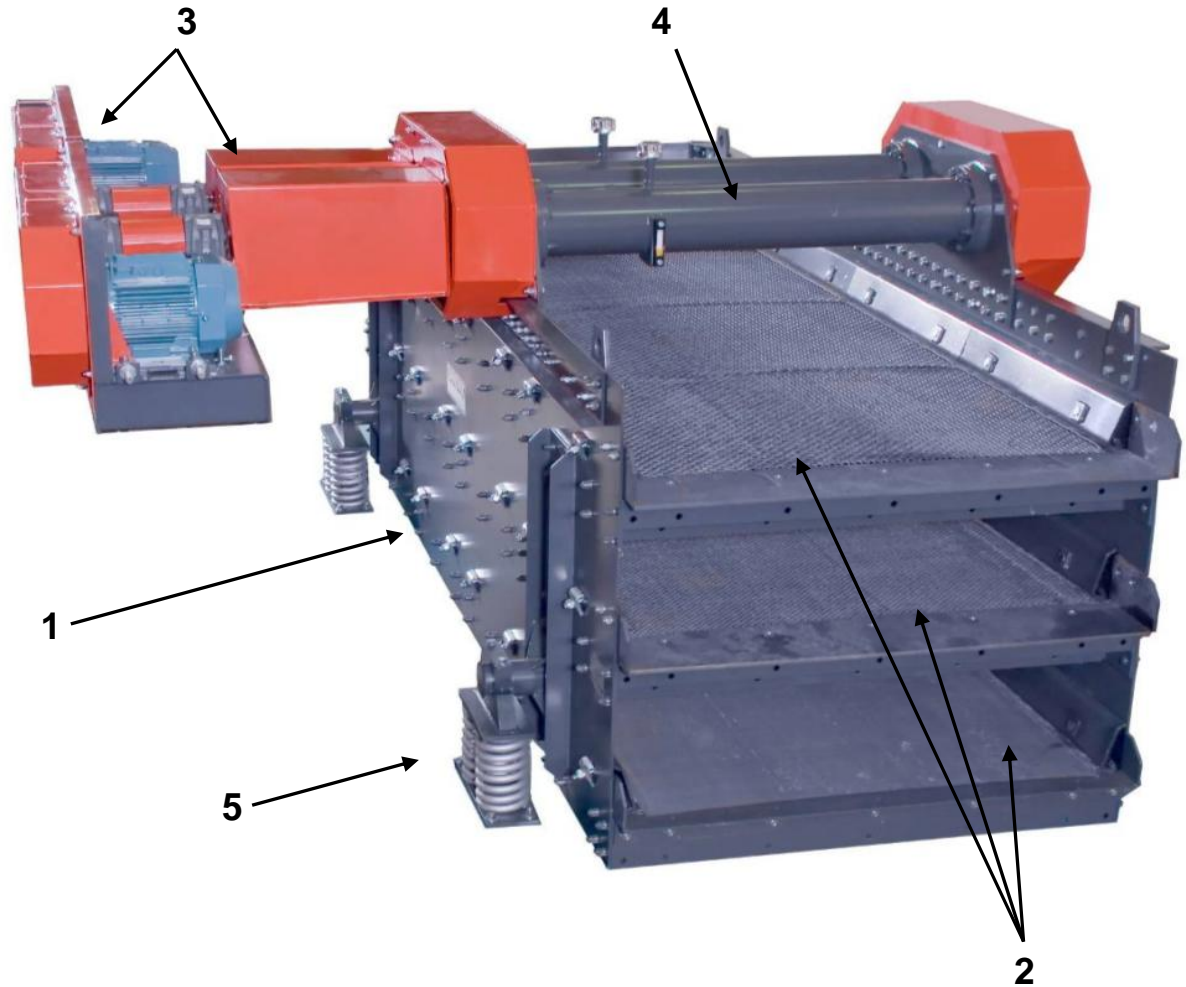

# Vibrating Screen

## TERMS

- Feed end
- Discharge end
- Hand of drive
  - ✓ Determined by looking from feed end to discharge end. I.e. Material flow direction.
  - ✓ In this case screen is right handed.
- Stroke angle
- Stroke length
- Equipment/serial number

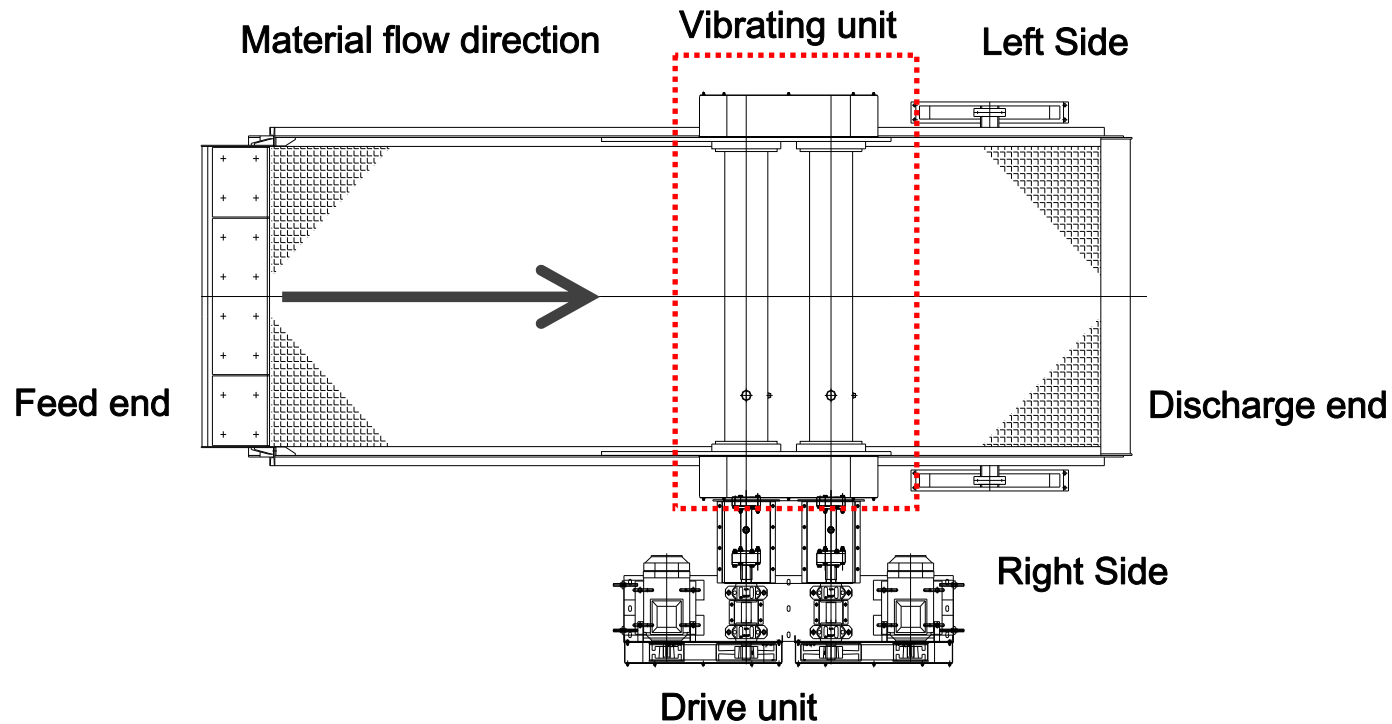



# Why is Accurate Screening Important !

- **Vibrating Grizzly Feeder (VGF)** – Removes fines from the feed material prior to the primary crusher. Another application would be to scalp-off dirty material which may be in the feed.
- **Primary Scalper** - Size primary material for secondary reduction and or to classify products (gabion or rip-rap stone).
- **Secondary Screen** - Size material for tertiary feed.
- **Tertiary Screen** - Final size and or separate material for quaternary circuit.
- **Final Screens** – Open circuit, to product piles.

# Why is Accurate Screening Important !

- Increase plant capacity.
- Reduce wear at all crushing stages (Keep the fines out of the crusher).
- Send material in the desired gradation to the correct stockpiles.
  - i.e. Inventory management
- Separate clean material for future reduction.

# Screening Theory

- Chemical crushing and mechanical crushing produce a sized and shaped material.
- Screens classify particles by size.
- All are related and effect the performance of each piece of equipment in the processing plant.
- Take home message: Value Chain – All are related and effect the profitability of the complete plant.

# Screening Theory

Accuracy defined:

- The degree of correctness of a quantity, expression, etc.
- Expressed as the ratio of allowable percentage of maximum oversize and undersize in the final product. I.e. 10/10, 10/20, 15/20...

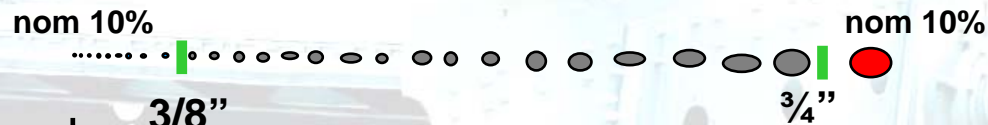

Efficiency defined:

- The percentage of work done.
- Normally expressed as; 80%, 85%, 90%, 95% objective screening efficiency, with no specific or defined reference to the allowable percentage of oversize or undersize in the product.
- Take home message: Afternoon workshop: Espada room, 3<sup>rd</sup> floor.

# Types of Feeders



Reciprocating Plate



VGF with Screen Deck



Vibrating Grizzly



Pan Feeders



XHD Scalper



Grizzly Screen

Including Belt Feeders  
\*\* Not pictured above



# Types of Motion

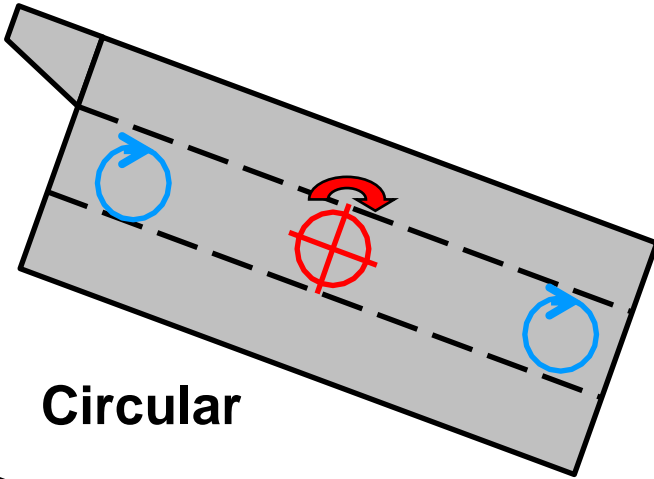

**Circular**

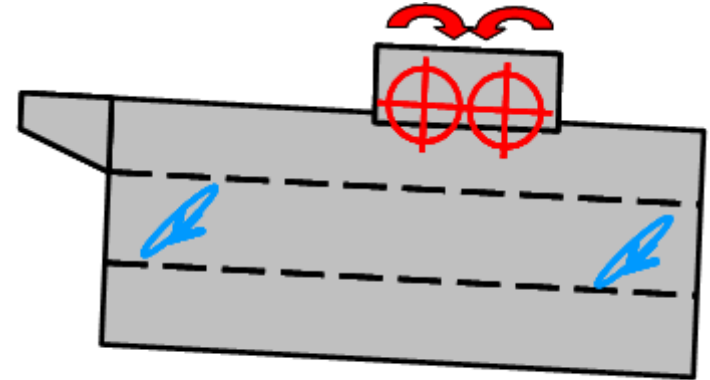

**Elliptical**

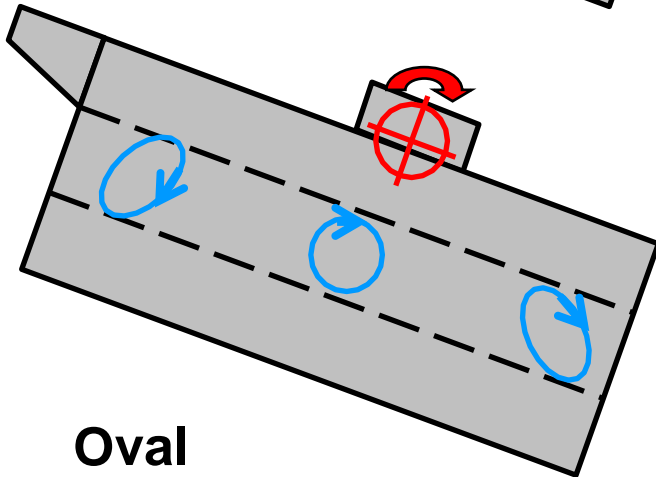

**Oval**

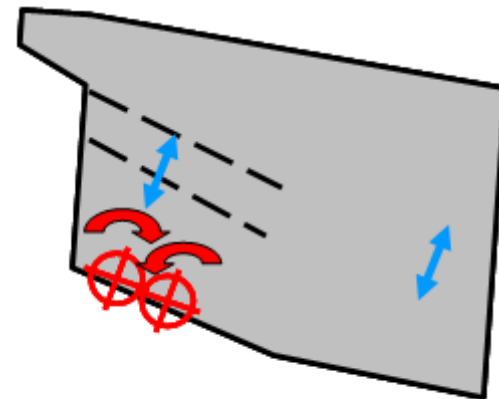

**Straight Line**

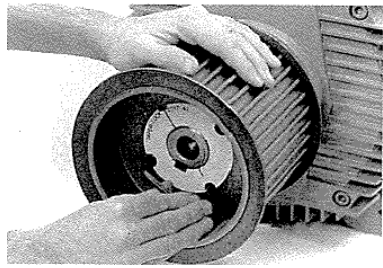

# Machine Drive (Exciter)

## Two bearing (per shaft line)

- Eccentric shaft design
- Concentric shaft design
- Counterweight

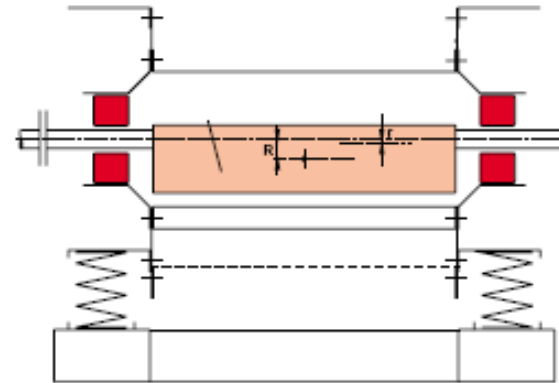
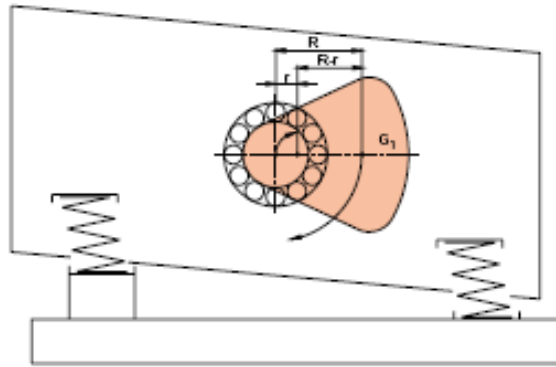
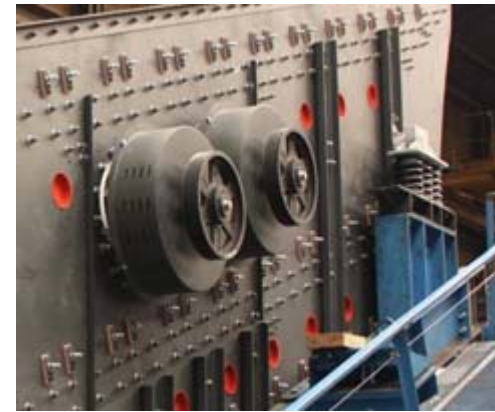

### Notes:

- Resultant circular throw if the exciter is located on the “center of gravity” of the screen box as illustrated above.
- If the exciter is located above the “center of gravity” or on top of the screen box, it will produce a forward ellipse at the feed end, circle throw below the exciter shaft line and reverse ellipse at the discharge end.
- If two shaft lines are required for increased bearing life or carrying capacity, the shafts are normally timed via a timing belt. In this scenario the shafts rotate in the “same” direction.



# Machine Drive (Exciter)

## Four bearing positive stroke

- Single eccentric crankshaft design
- Counterweight
- Circle throw - only

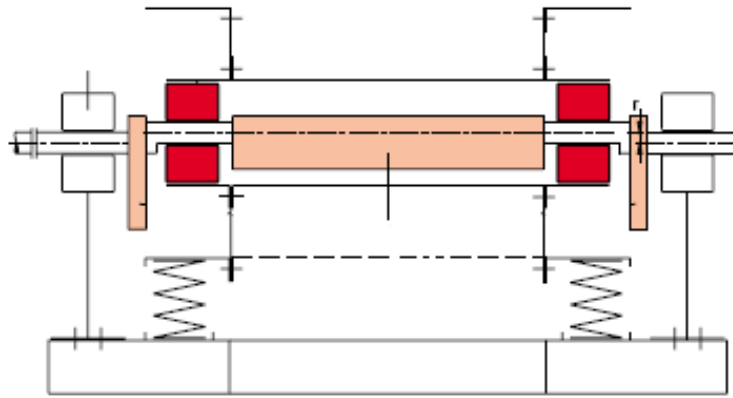

### Notes:

- Referred to as a “positive stroke” machine. Crankshaft design always produces a positive stroke similar to the crankshaft in a car. Used in the mining industry or in applications where high surge loads are common.



# Machine Drive (Exciter)

## Offset motors (Electric)

- Stub-shaft with counterweights
- Typically produce a straight line motion



Motor

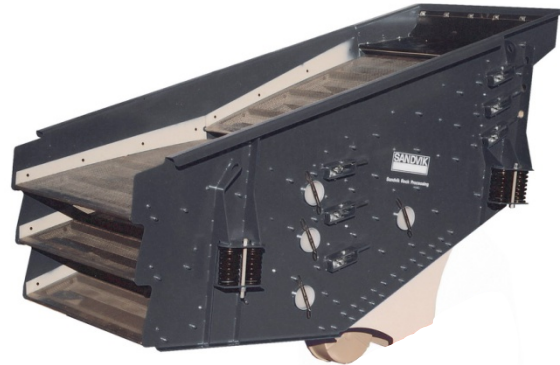

Motor



# Selection of your Screen: Application Information Required



- Duty/service
  - Secondary screen
  - Operating schedule
  - Stationary application
- Quality requirements/separation accuracy
  - Product sizes/specs required
- Feed gradation
  - (Sieve analysis)
- Bulk density of material
- Material characteristics
  - Wet, dry, sticky...
- Desired capacity
  - Feed rate
- Sizing media
  - Material (PU, W/C, Rubber...)
  - Brand (Stringers, side liners)
  - Openings (Per deck)
- Existing footprint
  - Size
  - Inclined (install angle)
  - Horizontal
  - Feed/discharge points
  - Motor horsepower
  - Spray system
  - Spring brackets
  - Weight
  - Hand-of-drive (From the feed end)

# Duties

Scalping Screen

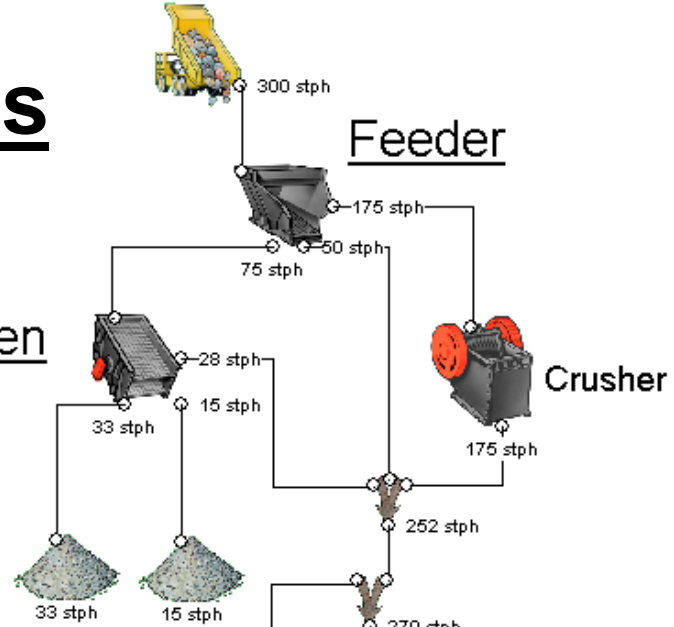

**Different duties in a plant**

Closed-Circuit

Finishing Screen

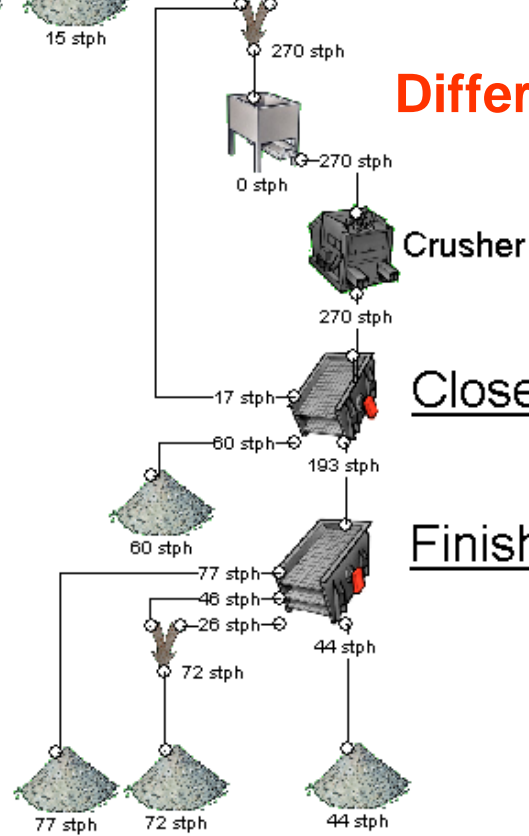

# Screen Duties

- To prevent undersize in the feed from obstructing the performance of the next reduction stage.

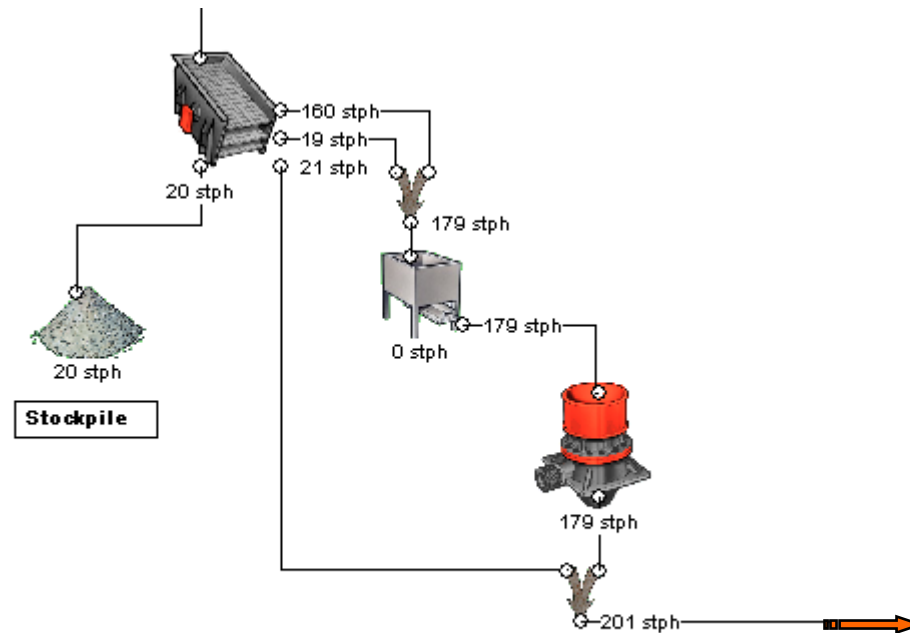

- **Take home message:** Keep the fines or sized product out of the next crushing circuit.

# Screen Duties

- To prevent oversize in the feed from moving onto the next process (Closed circuit).

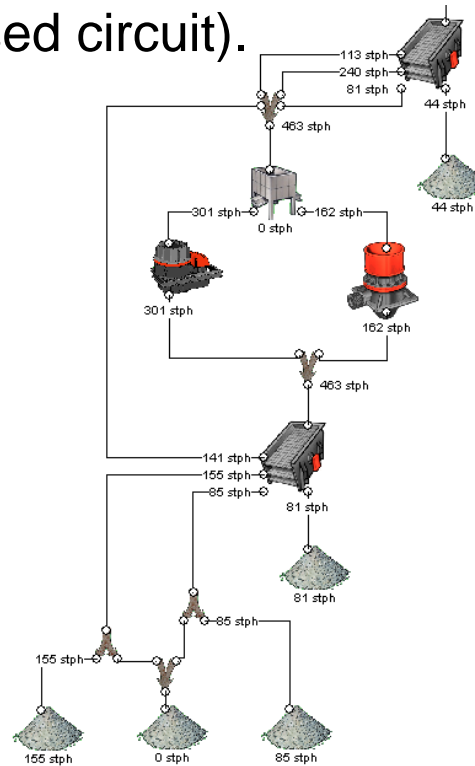

- Take home message: Closed circuit operation.

# Screen Duties

- To prepare a sized product.

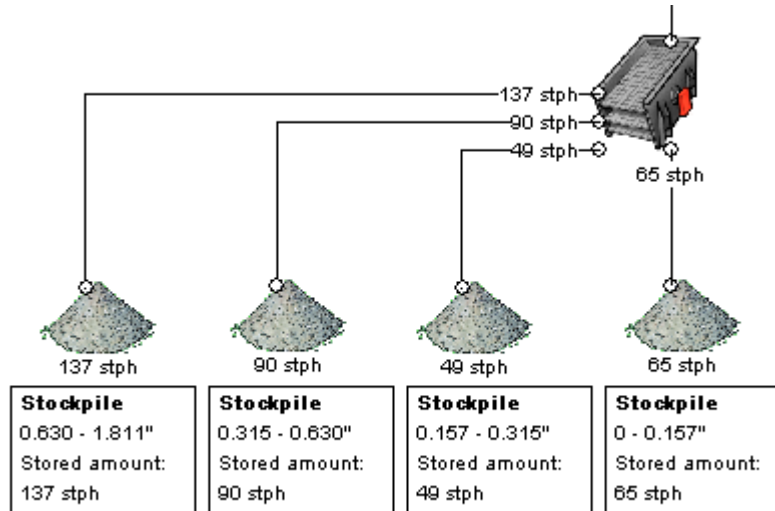

- Take home message: Final product sizing.



# Screen Performance

- Stratify the material.
- Prevent pegging.
- Prevent blinding.
- Separate the material into two or more fractions.
- Transport the material to provide the screen its carrying capacity!

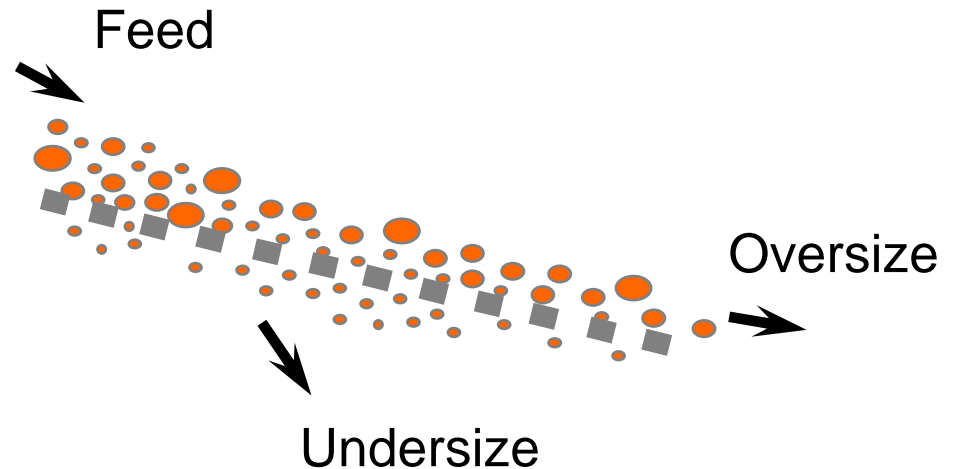

**Carrying Capacity**...the amount of material a screening machine can carry over the decks before the momentum of the screen body is overcome by the weight of the material.

# Which Bed Depth is Correct for Accuracy? (Discharge end)

- Maximum bed depth at discharge end is 4x the separation.
  - If too thick, probability is decreased for sized aggregate to properly stratify and pass through an opening.
- Minimum bed depth is 1x the separation.
  - If too thin, material can bounce, stay suspended and not stratify or find an opening, thus reducing accuracy.

# Which bed depth is right for stratification?

- ***A thin bed:***



- Becomes easily fluid, helps stratification.
- Shorter distance for fine particles to sift down to the deck.
- Less pegging tendency, stones are not forced down.

- ***A thick bed:***



- Can reduce accuracy.
- Overload the screen – carrying capacity.

# Factors Effecting Material Speed

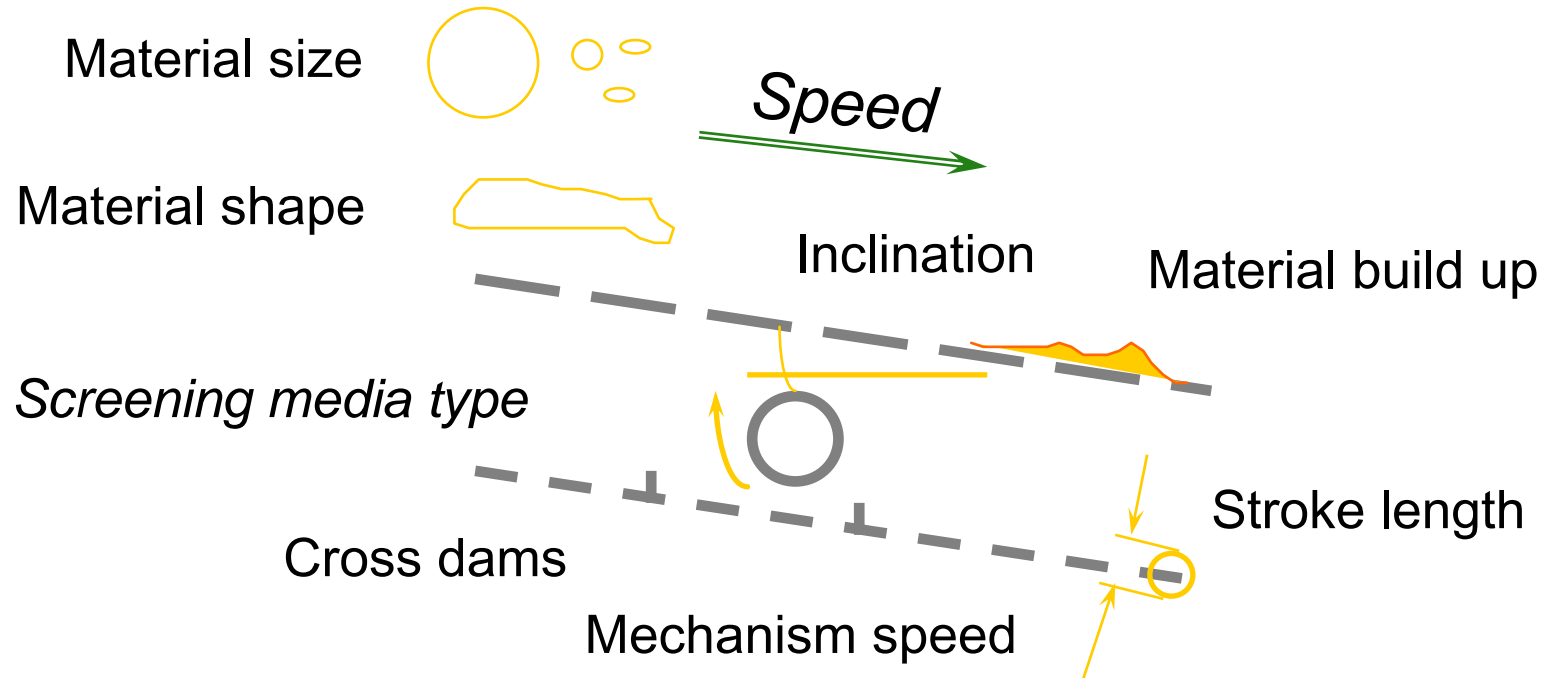

Gravity Free Fall = 32.2 ft/second

$$G_{\text{force}} = \frac{\text{RPM}^2 \times \text{Throw}}{70418}$$

$$G_{\text{force}} = \frac{800^2 \times 7/16''}{70418} = 3.9$$

# Steps to Improving Screen Performance

- Identify the improvement you want or determine the problem that you have with your vibrating screen.
  - *Examples: Increase tph, improve accuracy, cleaner product, reduce recirculating load, etc.*
- If you have a new problem, determine if something has changed in the circuit, material characteristics, crusher setting, screen opening, screen speed and stroke.
- Gather specific application data as it applies to that unit and seek assistance from the local dealer or manufacturer.
- Take home message: Every question is a good question!

# Options: Screening Media

- Woven wire cloth
- Plastic (Monofilament)
- Piano wire
- Rod deck
- Grizzly bar
- Louvered deck
- Profile deck
- Polyurethane (PU)
- Rubber
- Perforated plate
- Cast plate deck
- Rubber clad perforated plate





# Options: Dust Encapsulation

- Safety
- Good neighbor
- Sound
- Dust

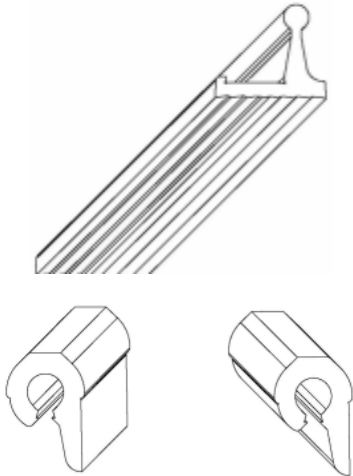
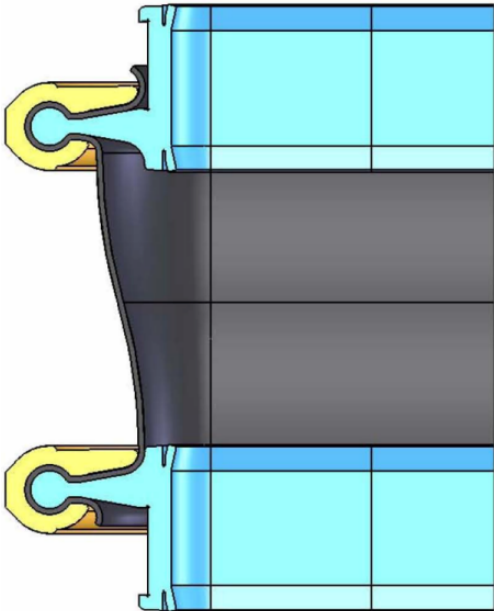
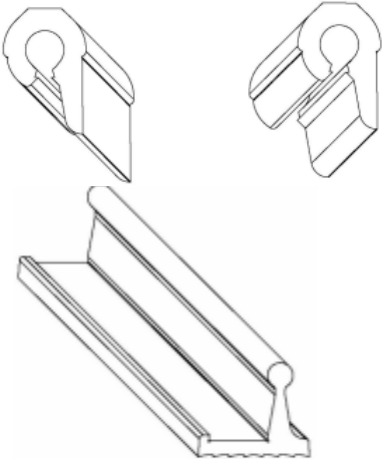
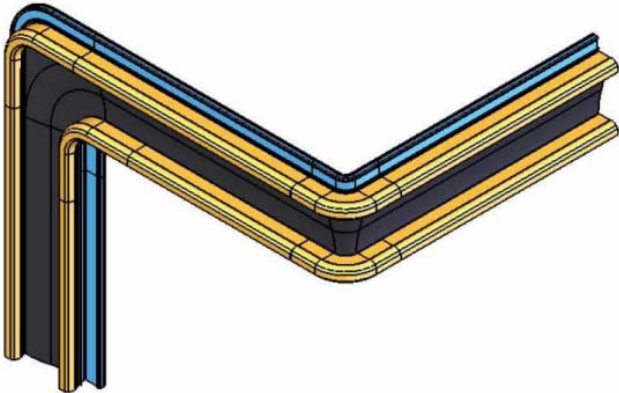

# Options

- Base frame
- Cardan shaft drive
- Liners
- Motor(s)
- Pivot type motor base
- Special paint or coating
- Steel structure
- Spray bar system....



# Conclusion

- It has been said that screening is part “Science” and part “Art”. Today we have many tools and empirical data to assist with correct unit sizing, media and open area selection for almost any application.
- My best advice is safety first. When a screening issue arises, always look for the obvious (broken spring, belt too tight or too loose, broken cross member, loose bolting hardware).

Take home message:

Lockout – Tagout always.

Screens are often the critical link in the value chain.



*[www.quarryacademy.com](http://www.quarryacademy.com)*



---

**QUARRY  
ACADEMY**

**LIGHTEN UP!**