

# Crushing

## Principles of Mechanical Crushing



Improving Processes. Instilling Expertise.

• **SUSTAINABILITY** •

• PROFITABILITY •

• PRODUCTIVITY •

BREAK  
ROCK

Chemical  
Crushing

MOVE  
ROCK

Load and  
Haul

SIZE  
ROCK

Mechanical  
Crushing and  
Screening

• PLANNING AND METRICS •

• **SAFETY CULTURE** •

# Objective

Explain the interaction between  
rock material  
and  
crusher



# Take home messages

The Take Home Messages will address:

- Trouble Shooting
- Improve Yield
- Improve Performance



# Agenda

- Crusher Application
- Cone Crusher Operating Principle
- Crusher Capacity
- Crusher Operation
- Optimization and Crusher Performance Map
- Conclusions

# Crusher Selection

Feed size

5"

15"

20"

40"

60"

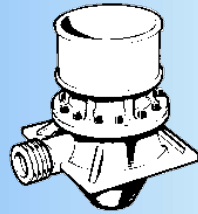

[< 5]

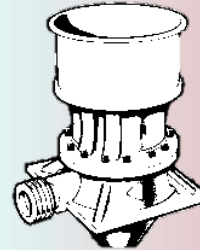

[< 5]

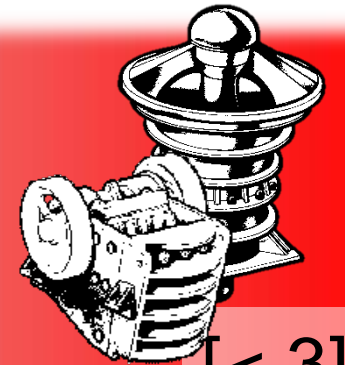

[< 3]

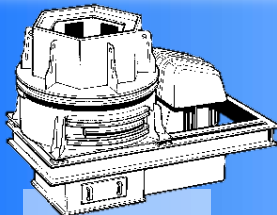

[< 5]

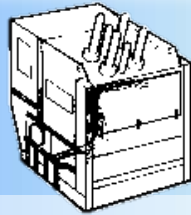

[< 10]

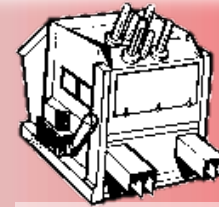

[< 10]

[Reduction Ratio]

# Crusher Selection

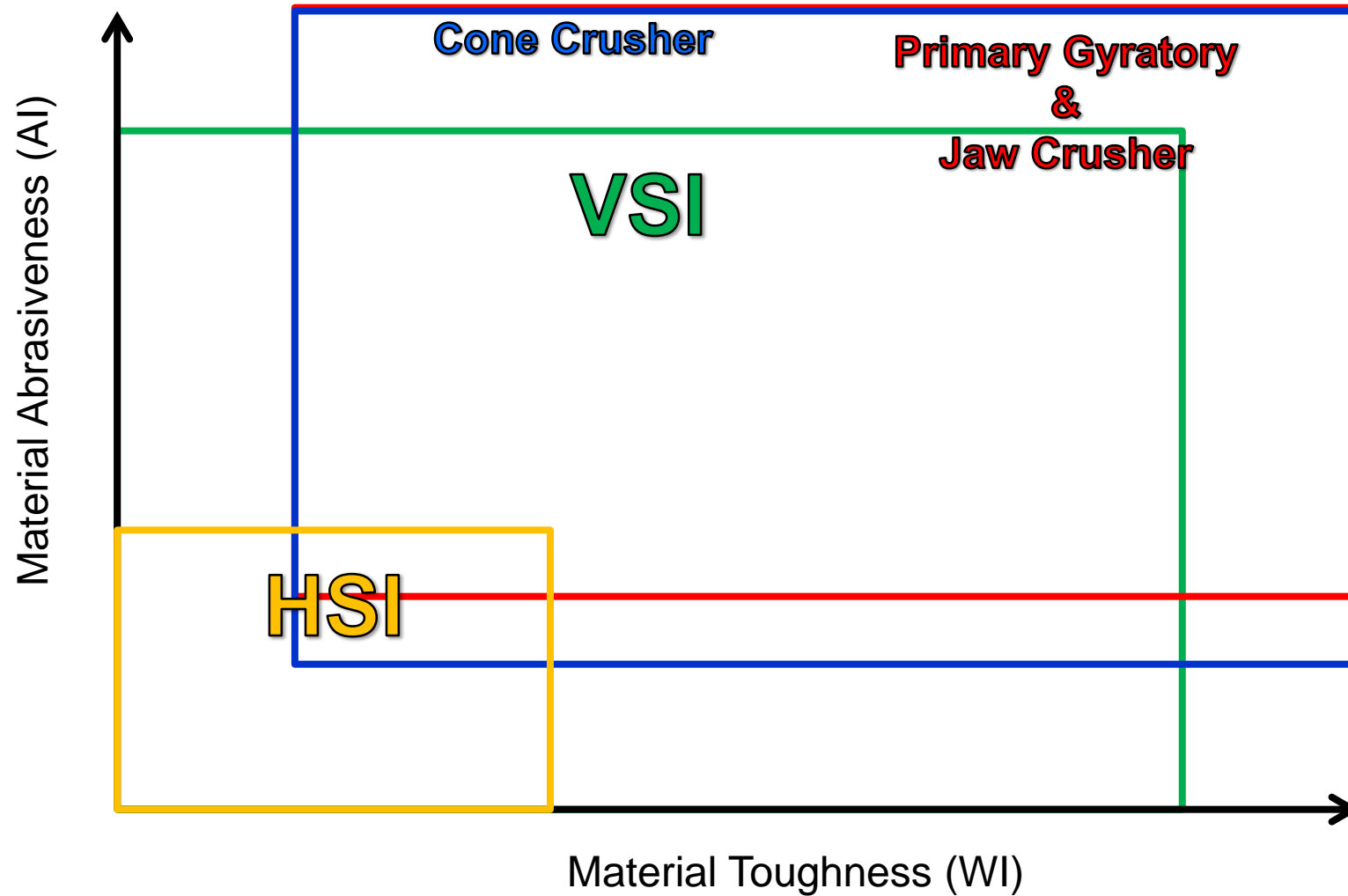

# Crusher Selection

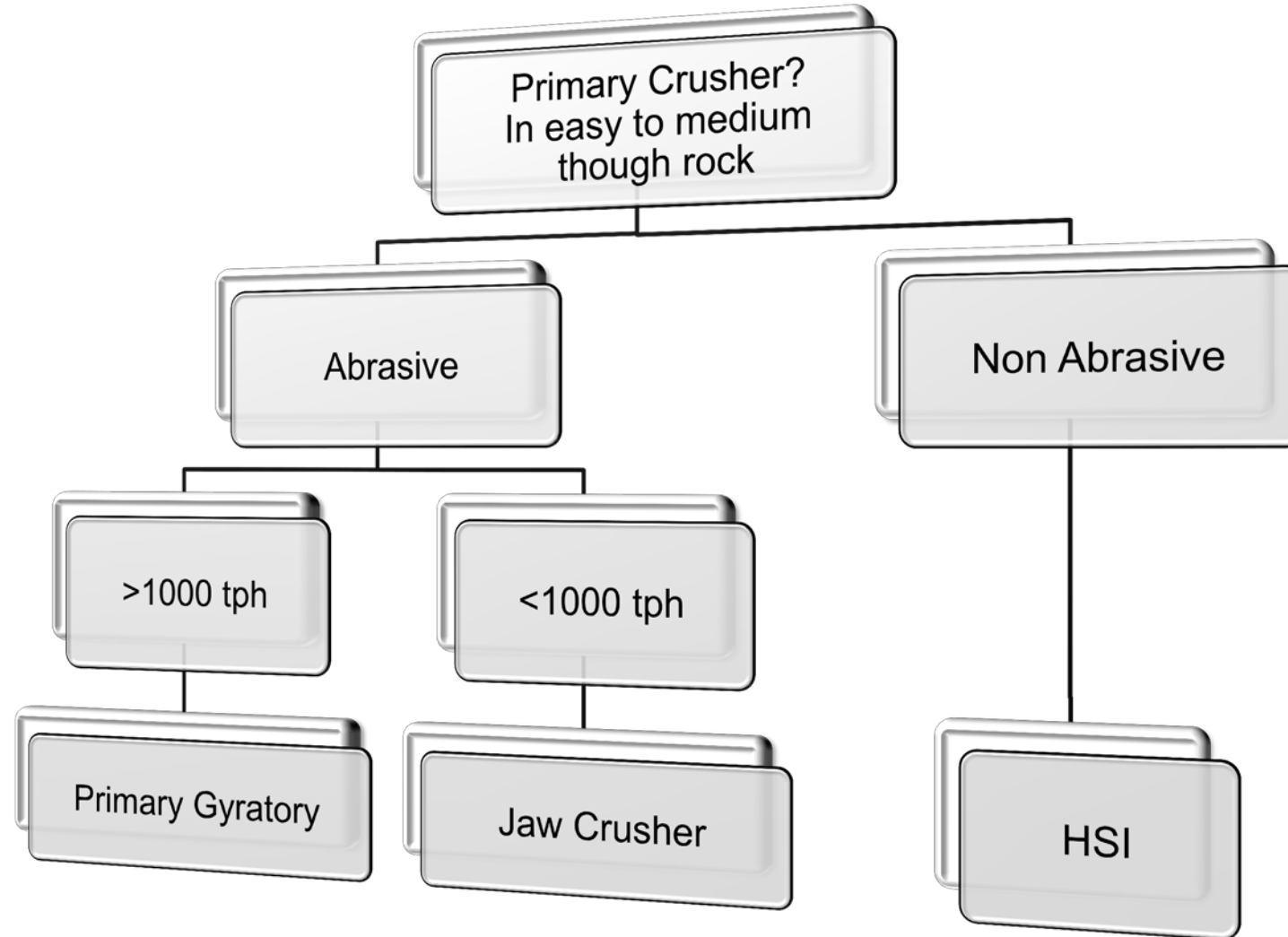



# Cone Crusher

- Why Cone Crusher?
- The cone crusher design concept is an effective and smart way of realizing compressive crushing
- Aggregate Production
- Mechanical Liberation of Valuable Minerals



# Operating Principle

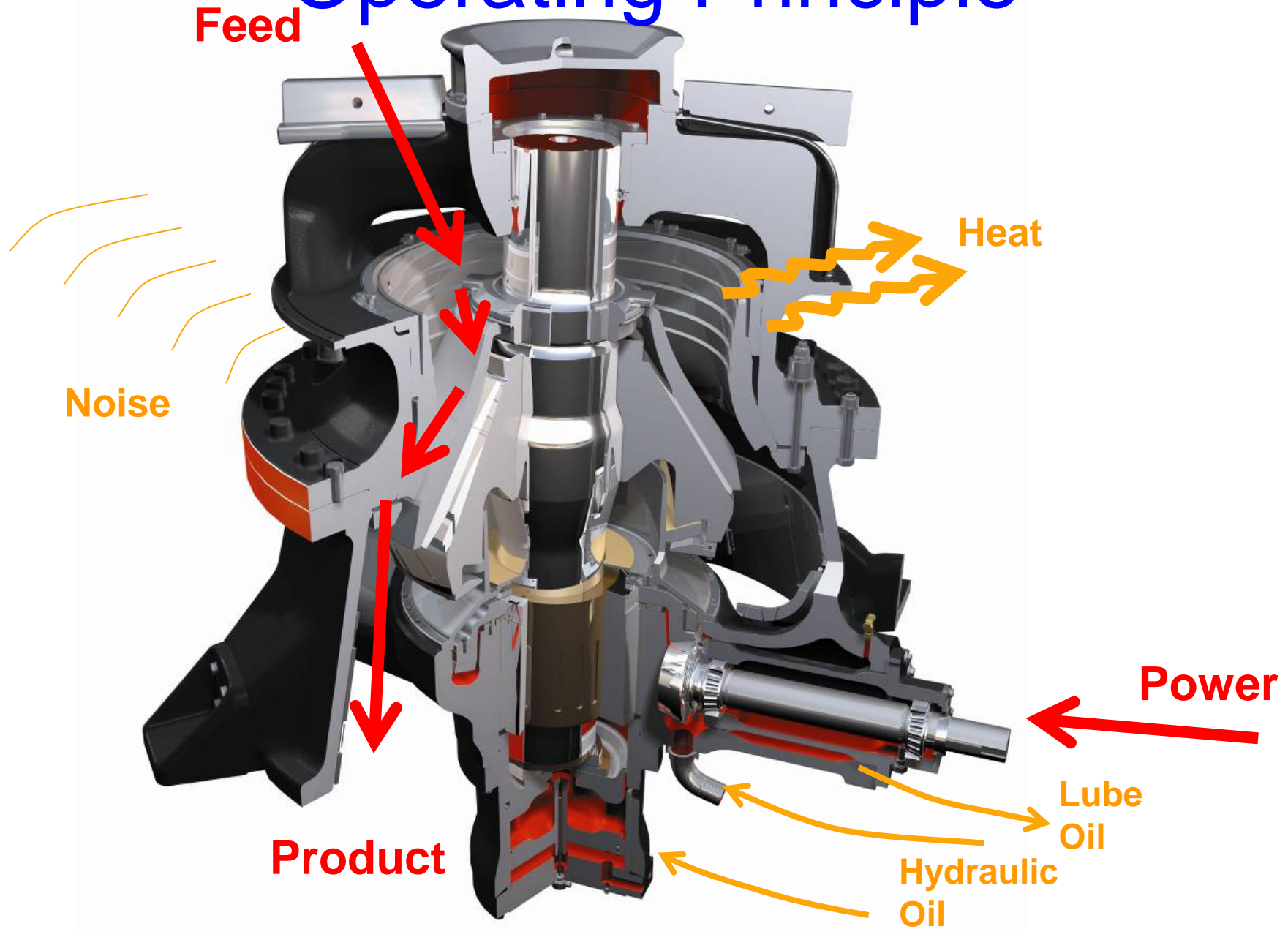

# Operating Principle

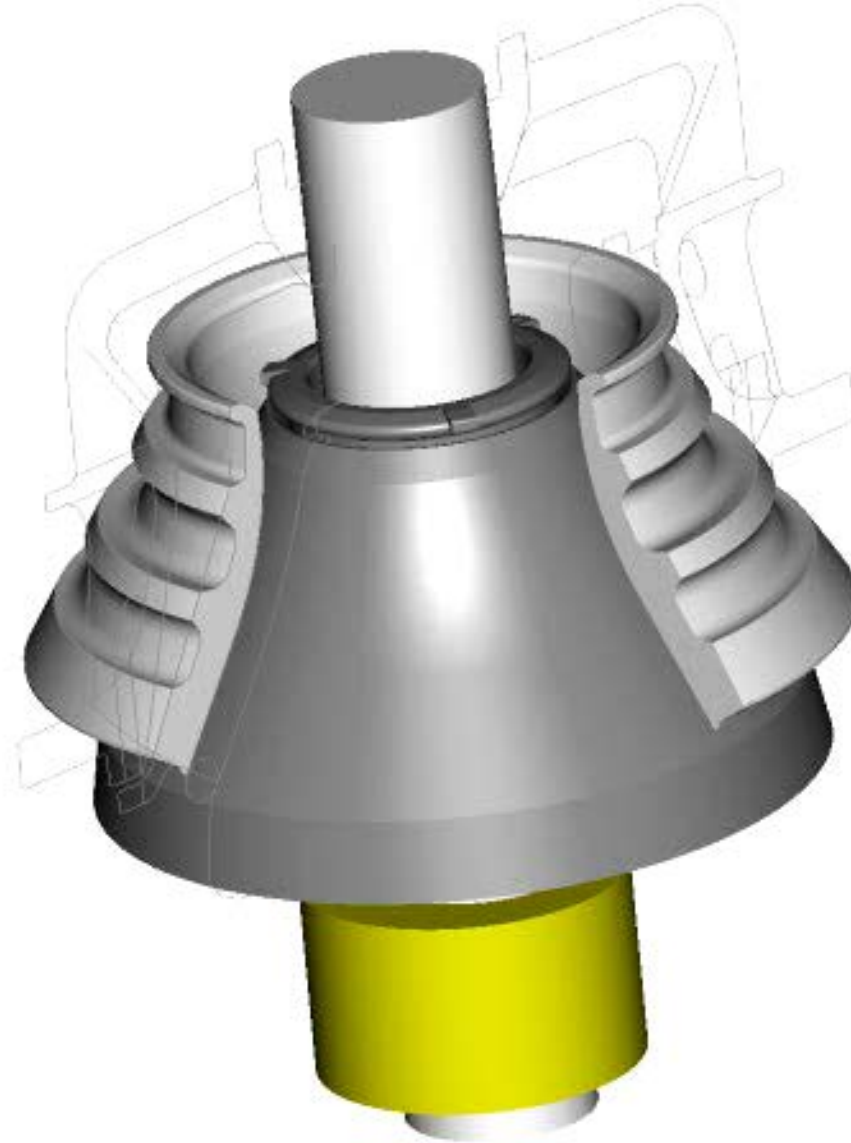

# Operating Principle

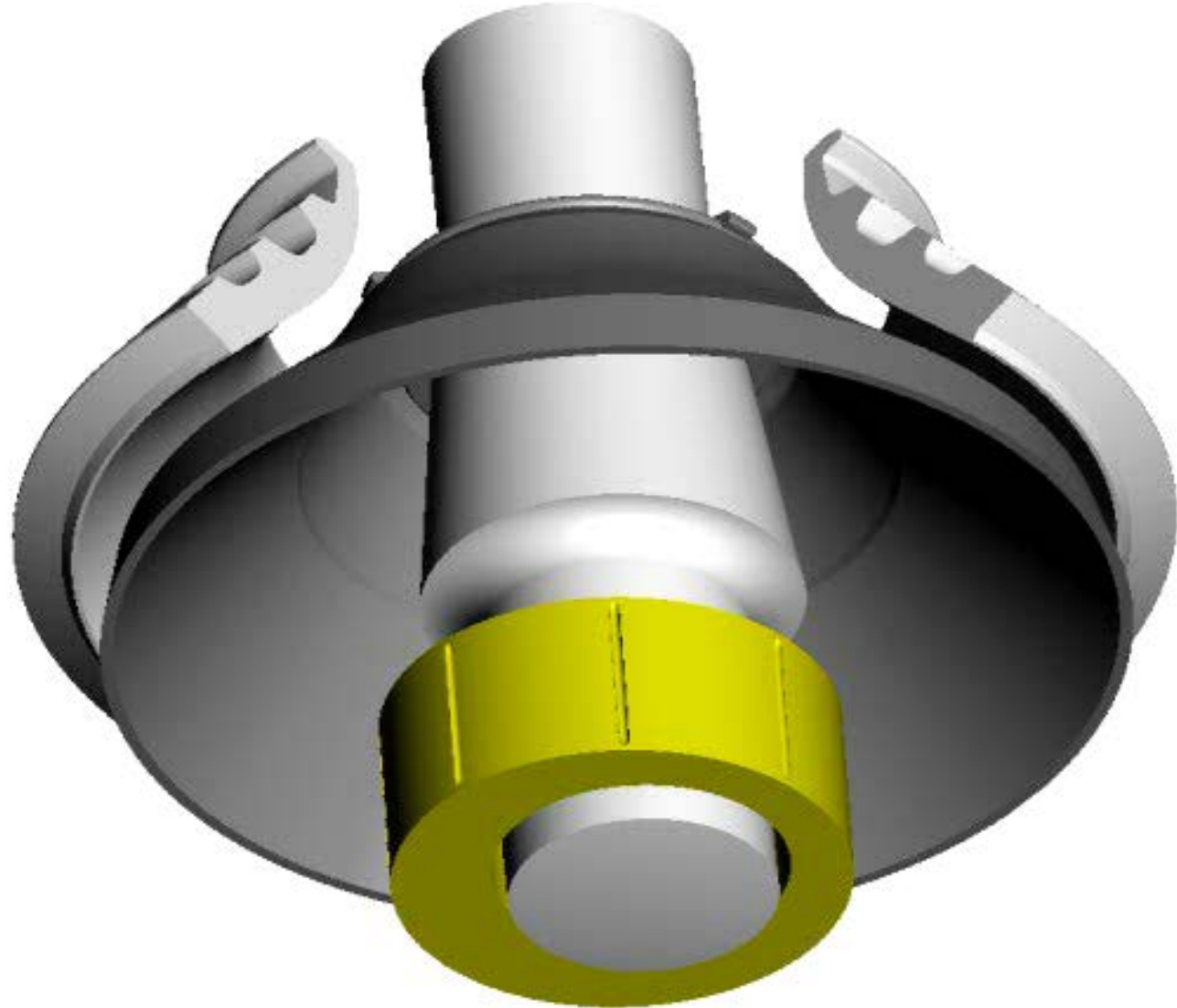

# Operating Principle

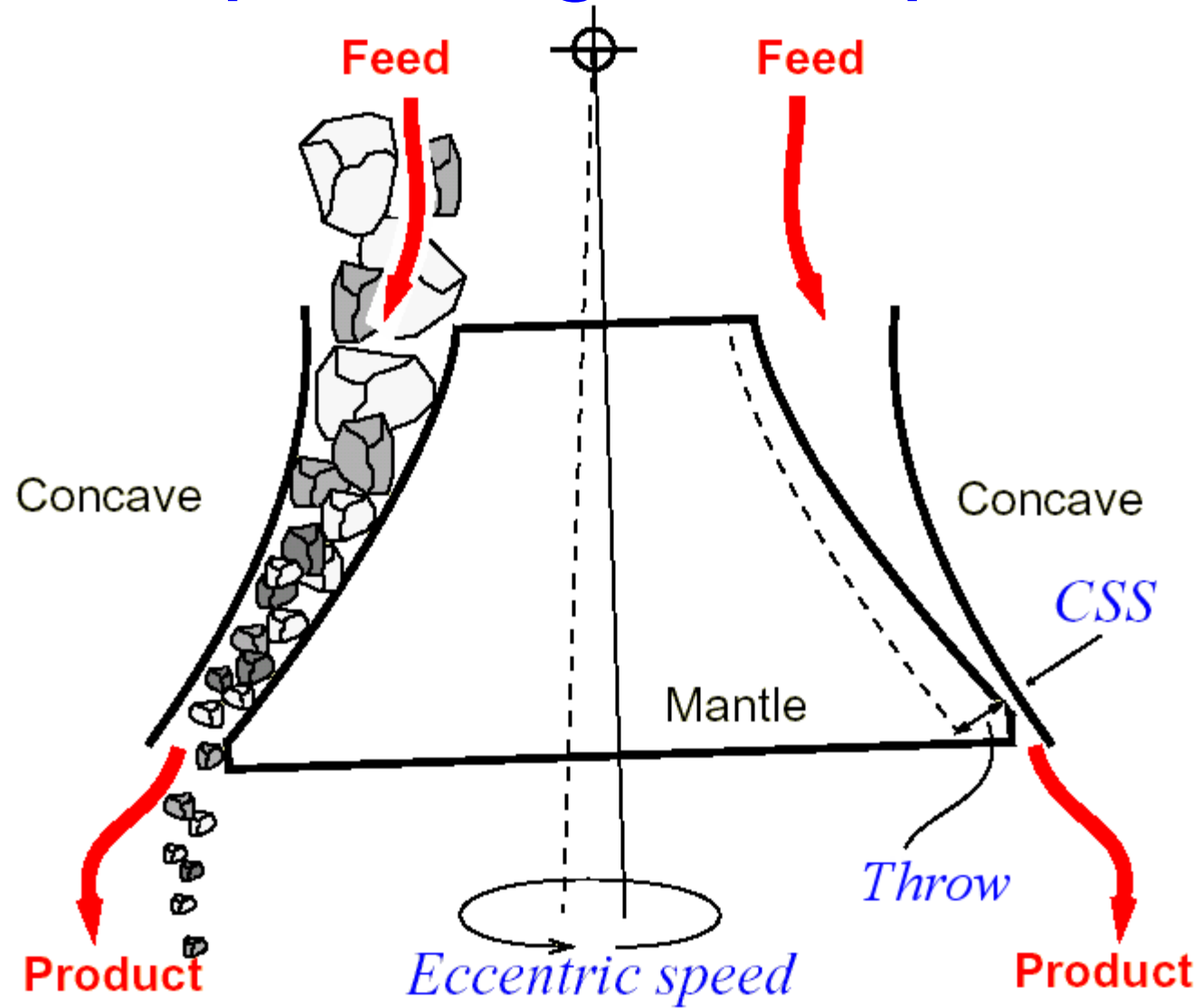



# Operating Principle

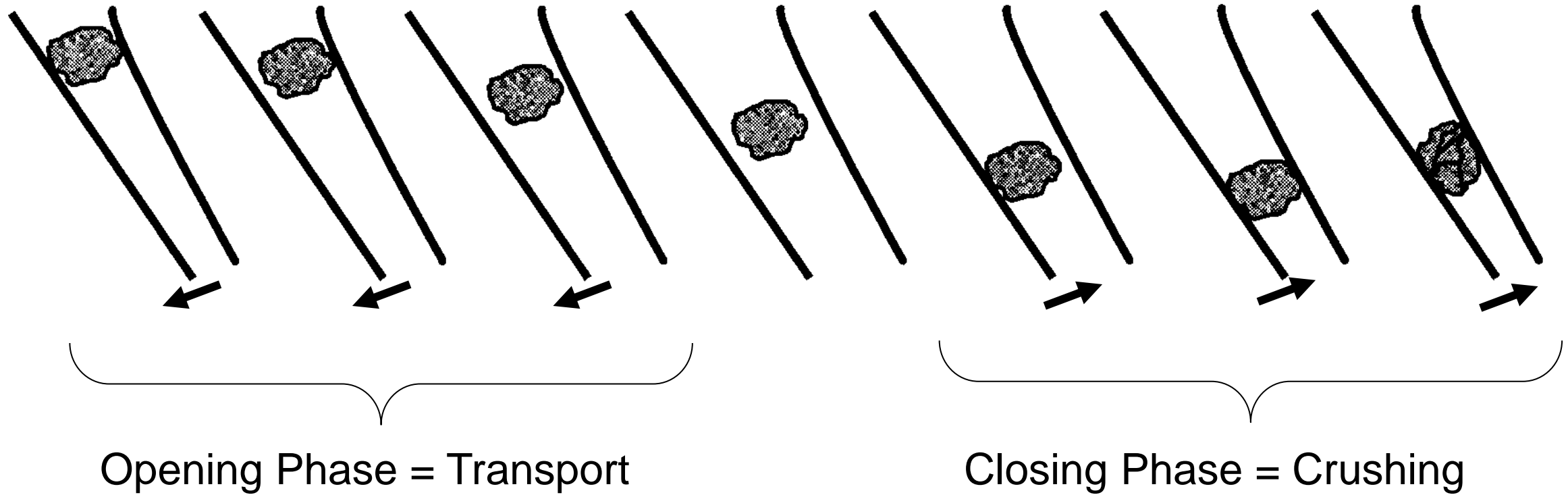

# Operating Principle

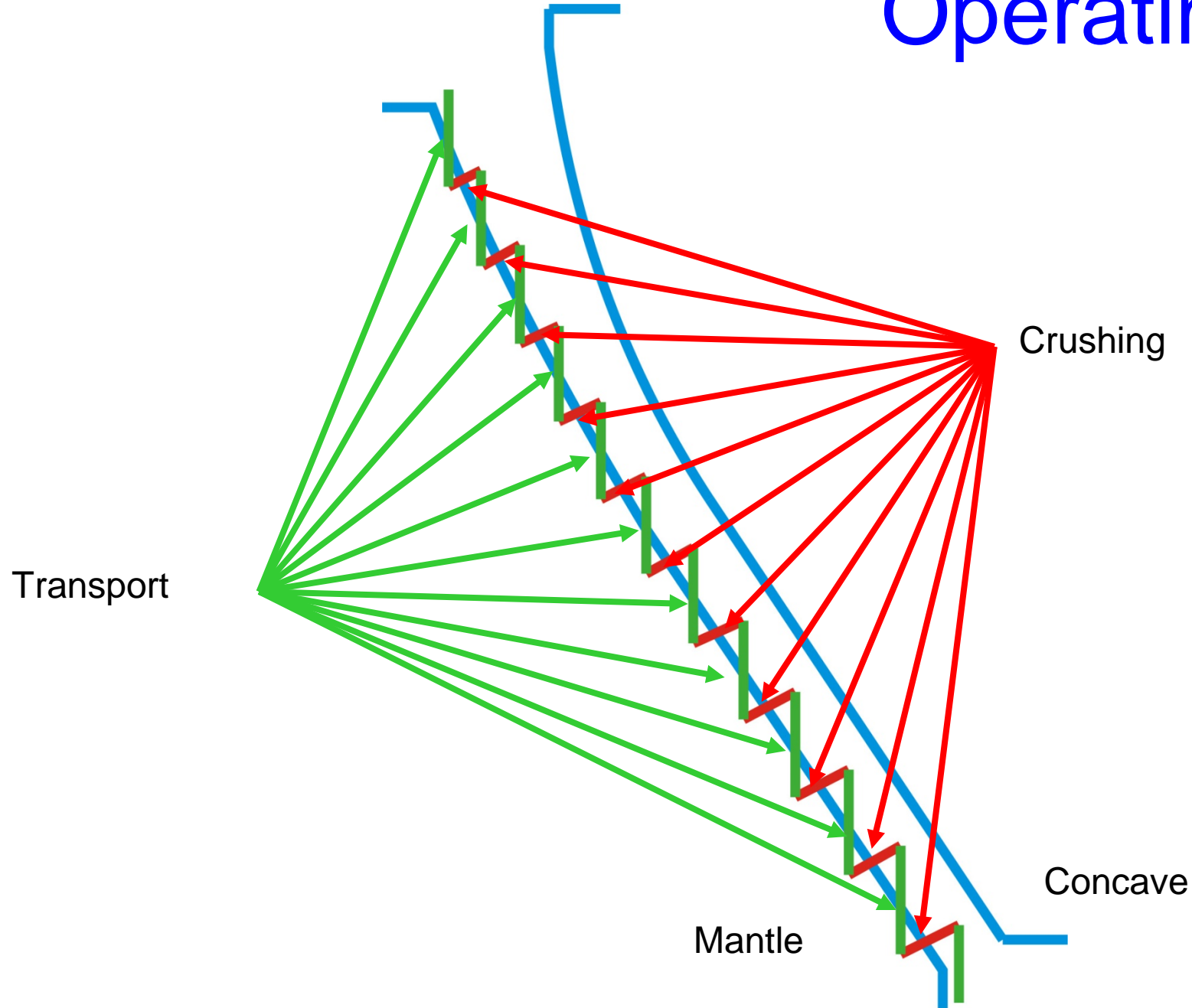

# Operating Principle

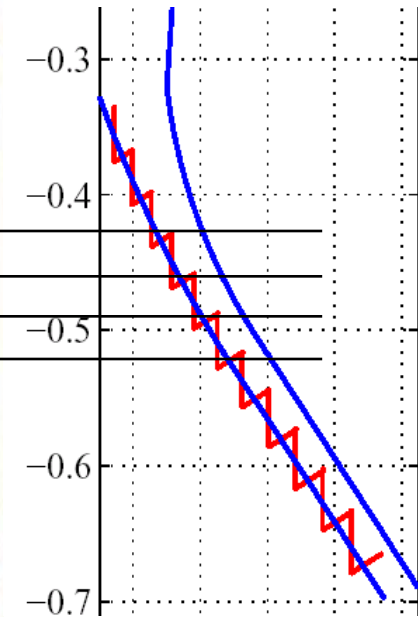
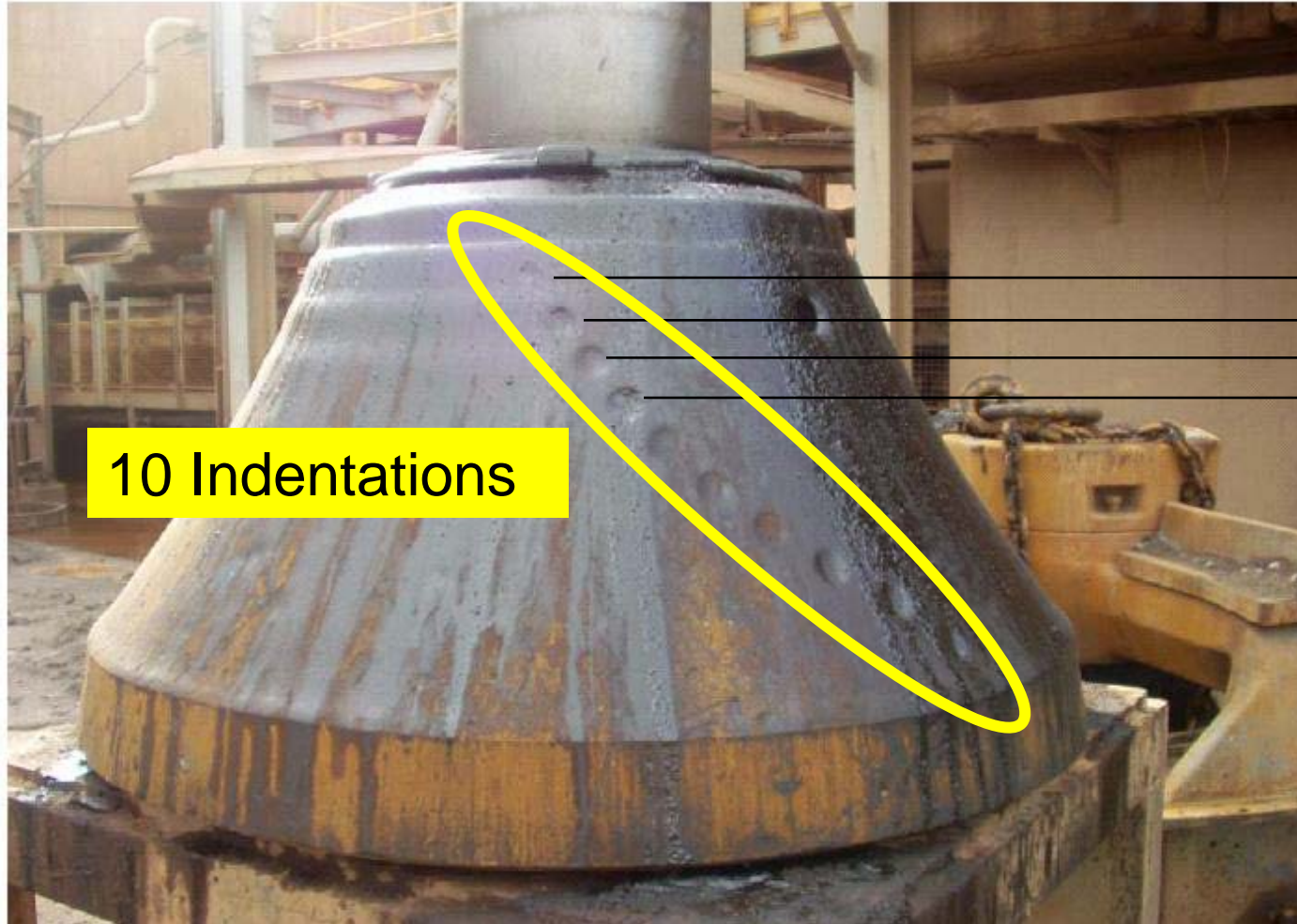

# Operating Principle

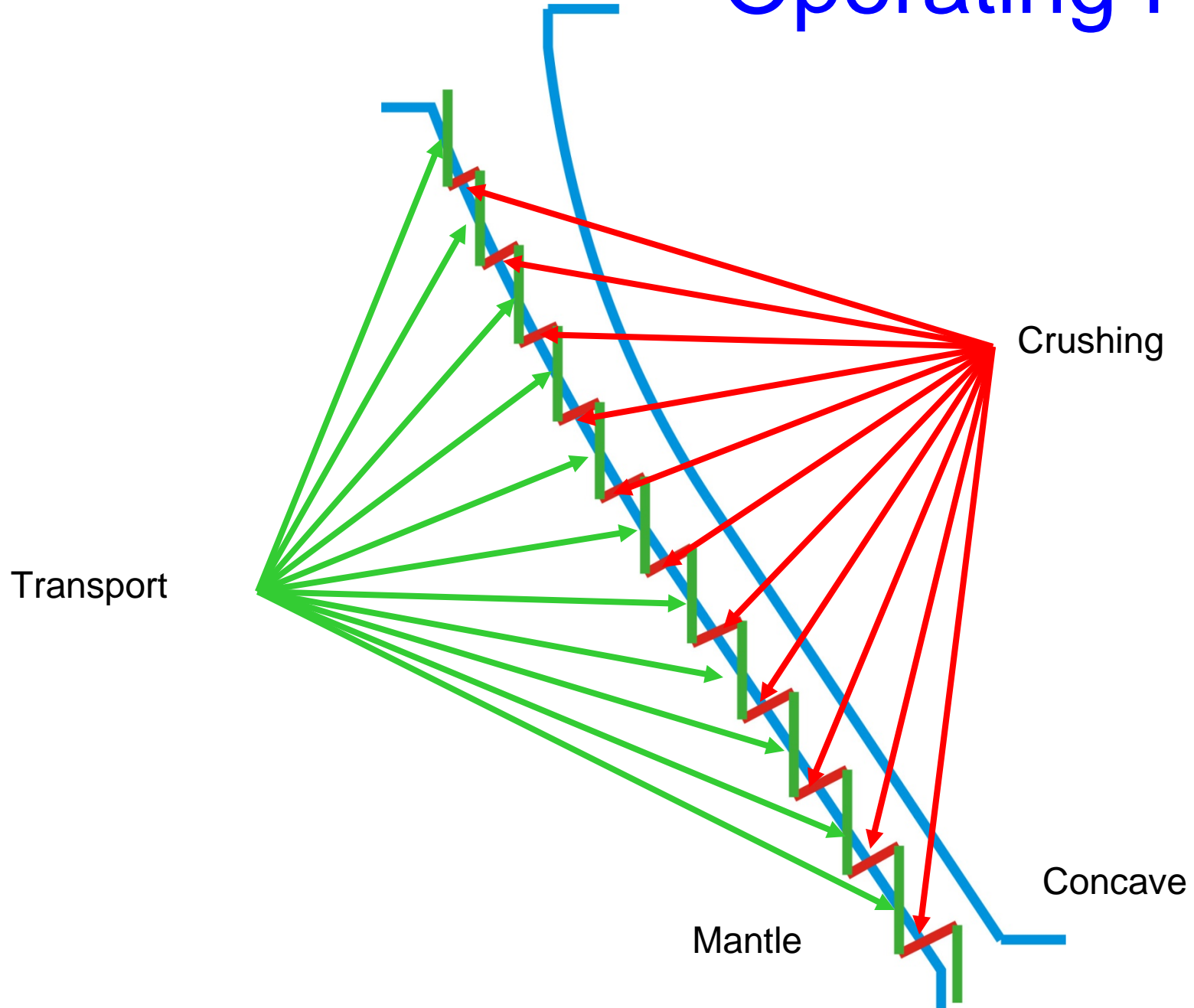

# Operating Principle

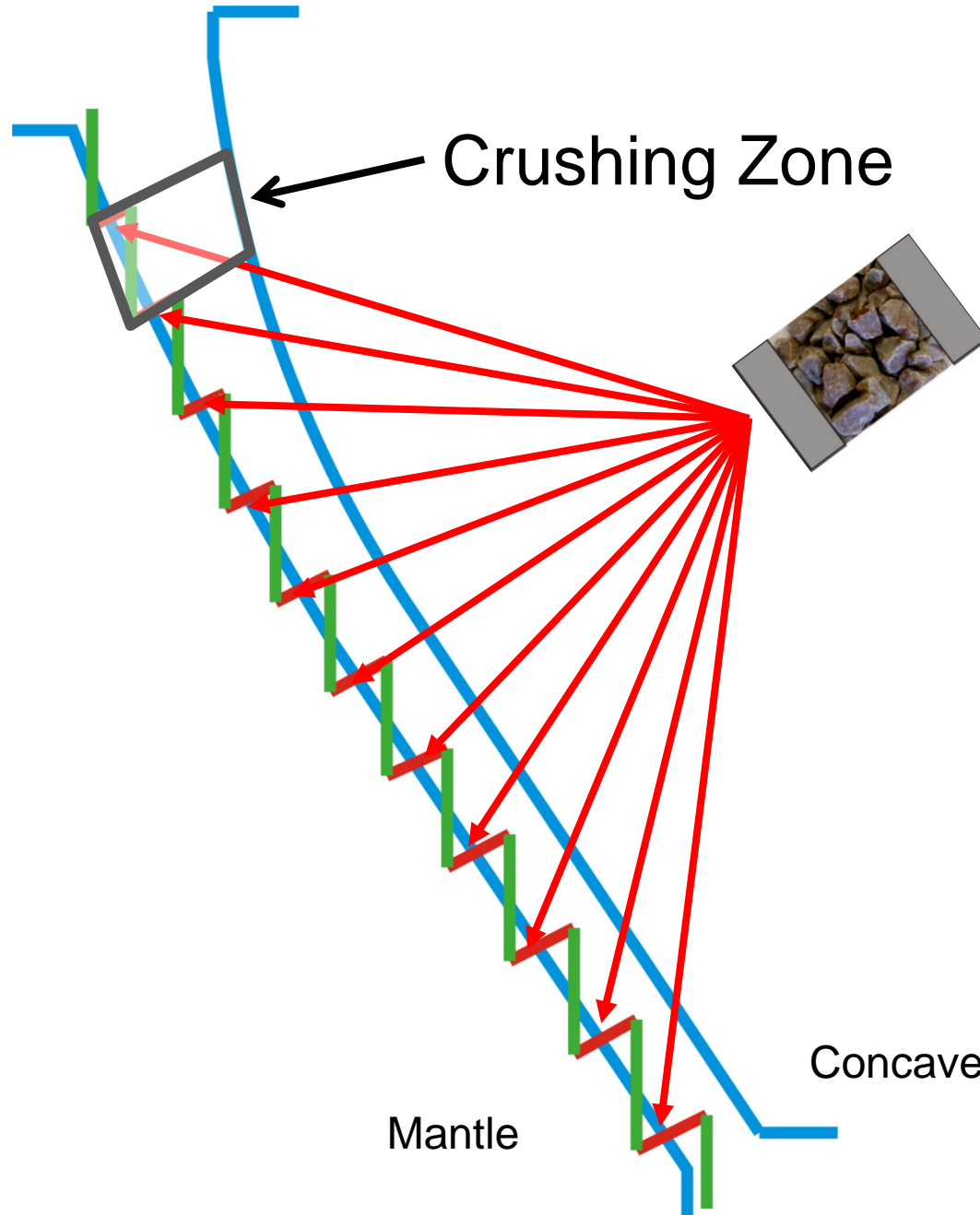

## Single Particle Breakage SPB



## Inter Particle Breakage IPB





# Operating Principal

- In a cone crusher the stones are crushed with both SPB and IPB as the material moves down through the chamber.
- The relative amounts of IPB and SPB depends on factors like chamber design, crusher geometry, speed, css, eccentric throw, and others.

**SPB**



**IPB**



Fines	Less	More
Shape	Flaky	Cubic
Force	Low	High

# Crusher Capacity

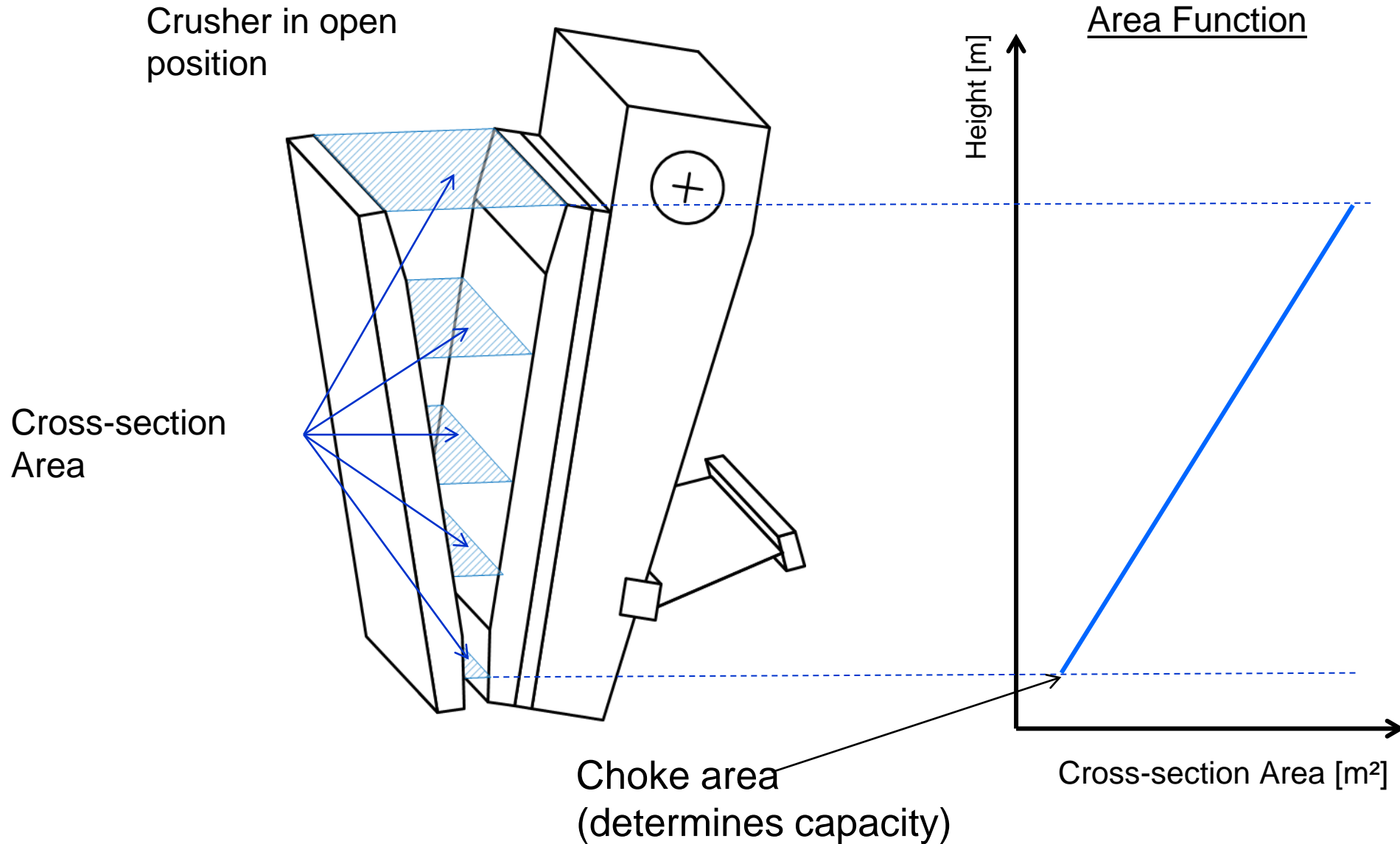

# Crusher Capacity

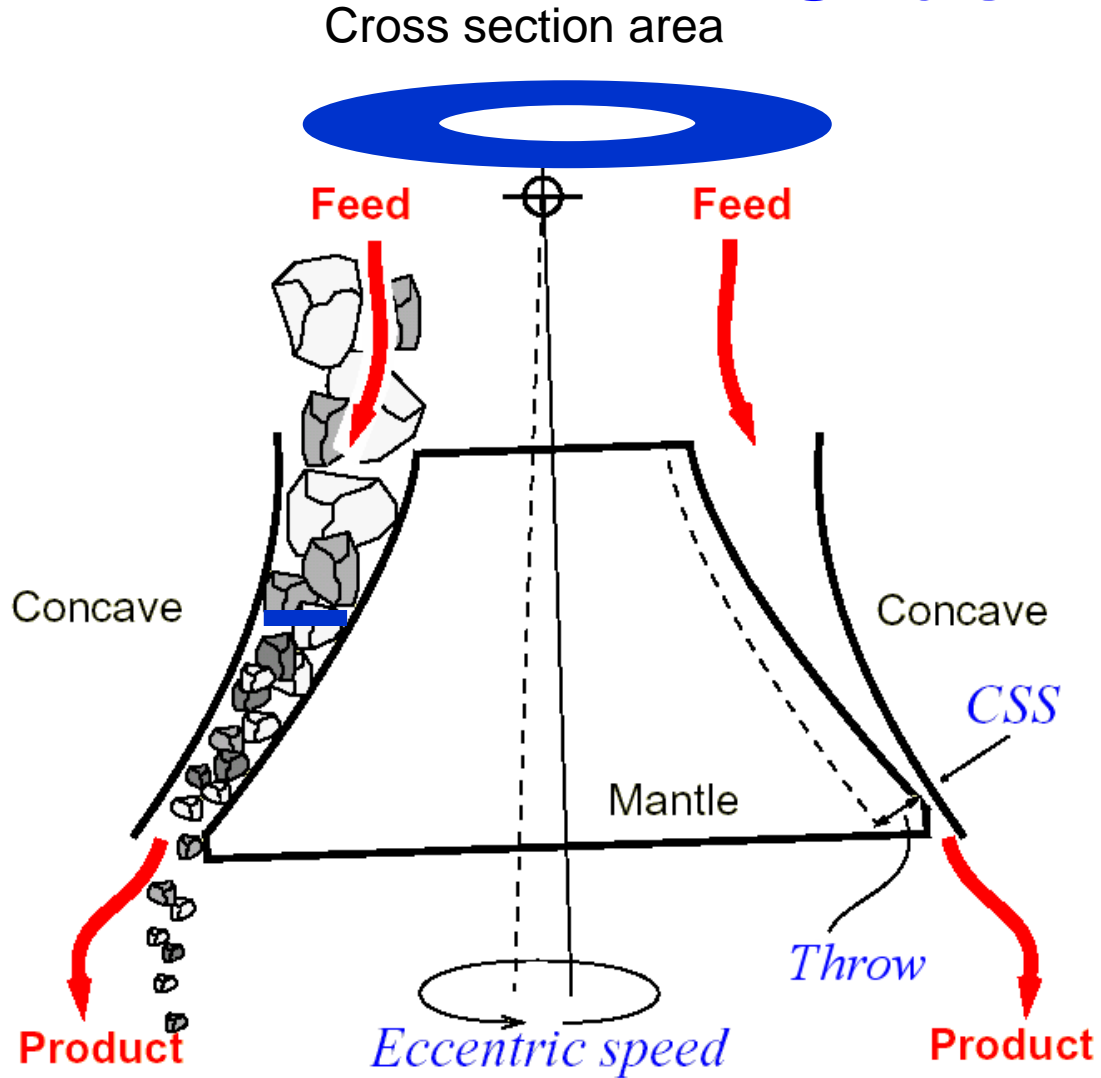

## Area function

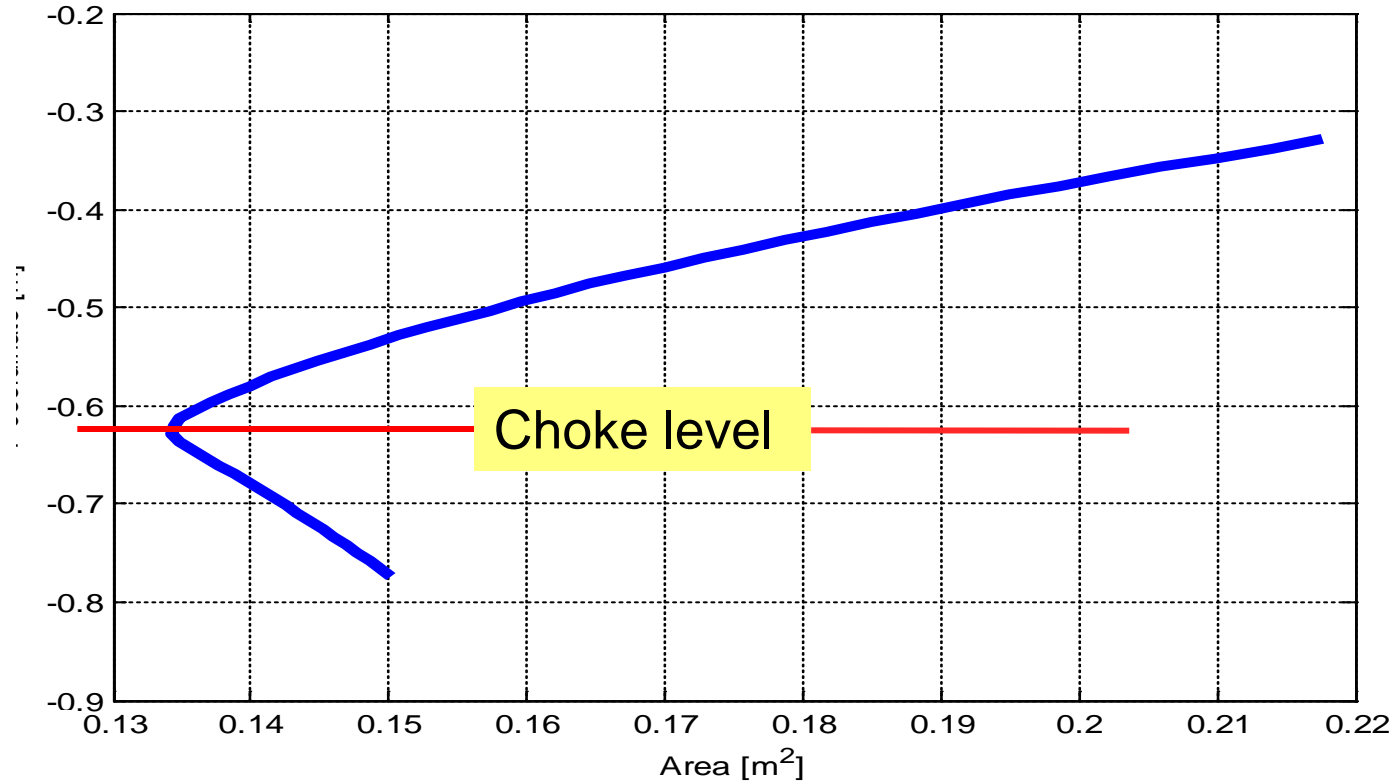

# Crusher Capacity

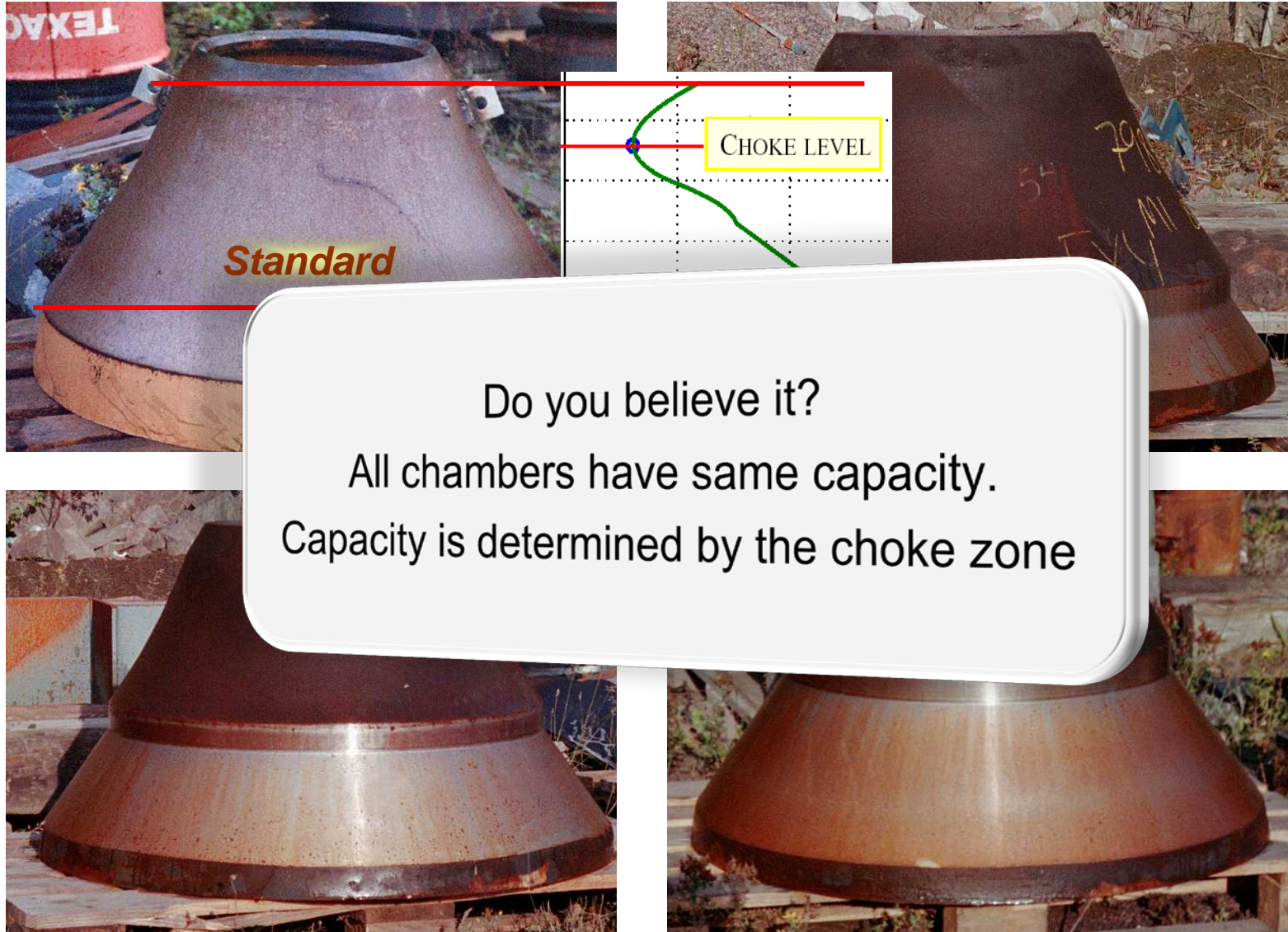

# Crusher Operation

- As the market demand shifts can the crusher operation be modified?
- The crusher is likely to be installed for maximum production. Can it be changed to maximum efficiency?
- Understanding how breakage and capacity is effected by
  - Eccentric Throw
  - Speed
  - Closed Side Setting



# Crusher Operation

## Running the crusher at different eccentric throws

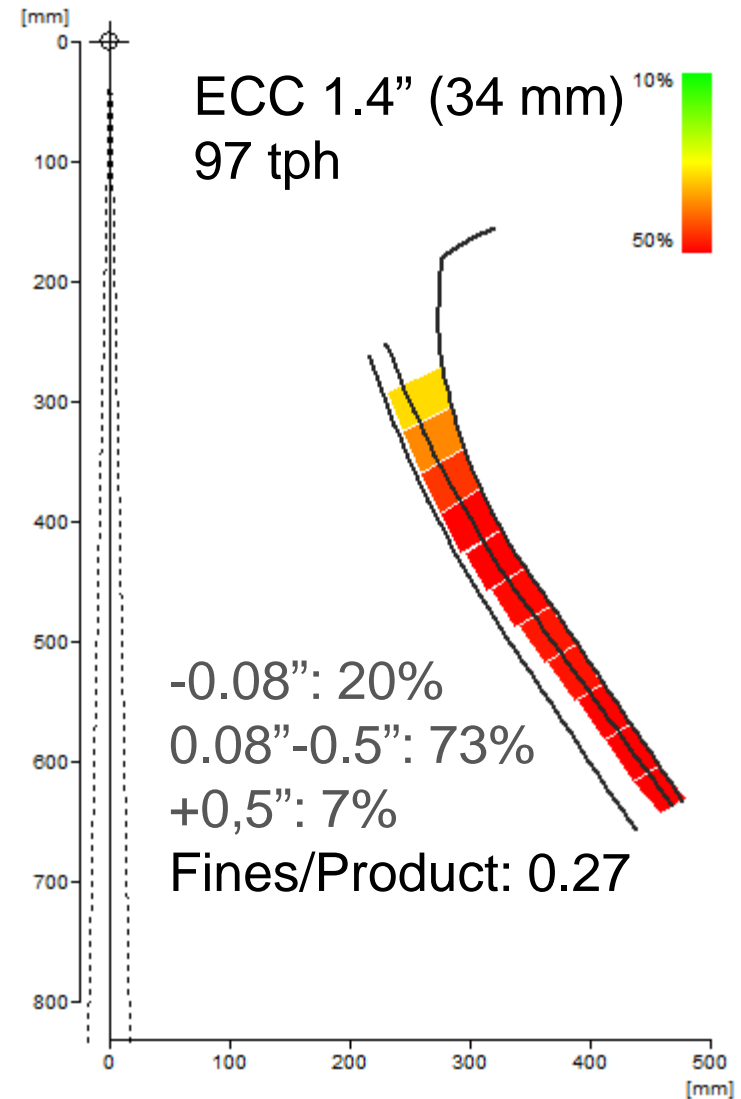
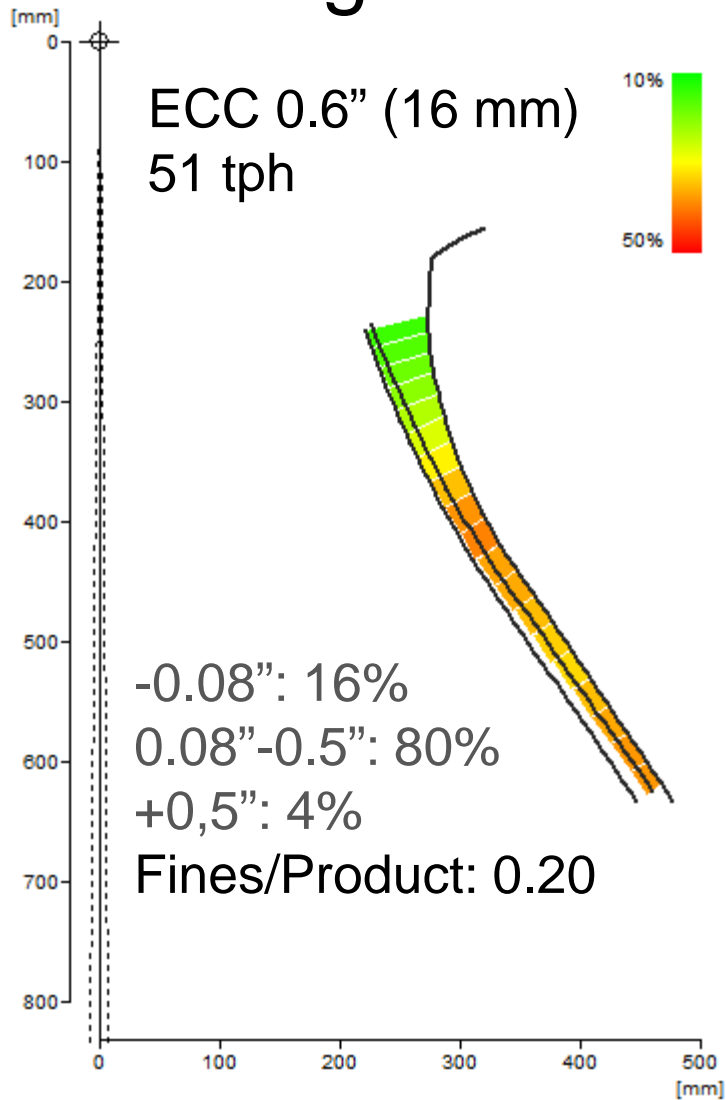

# Crusher Operation

- Running the crusher at different eccentric throws, CSS optimized

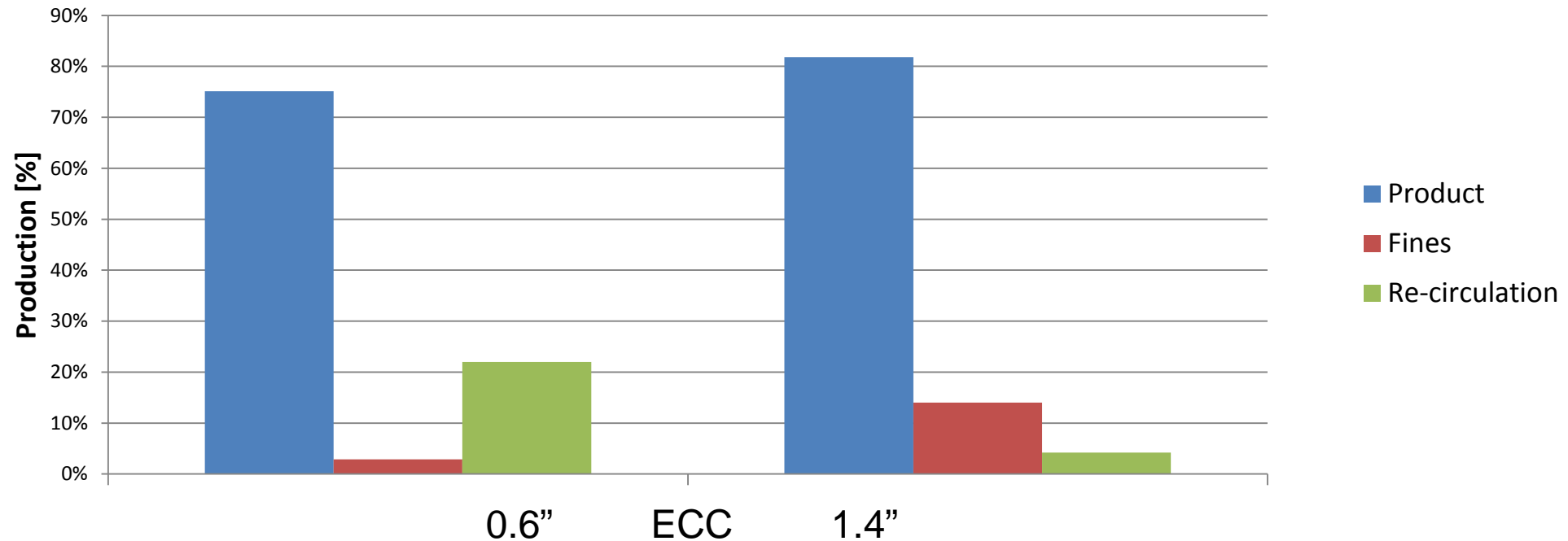

# Crusher Operation

- Running the crusher at different speeds

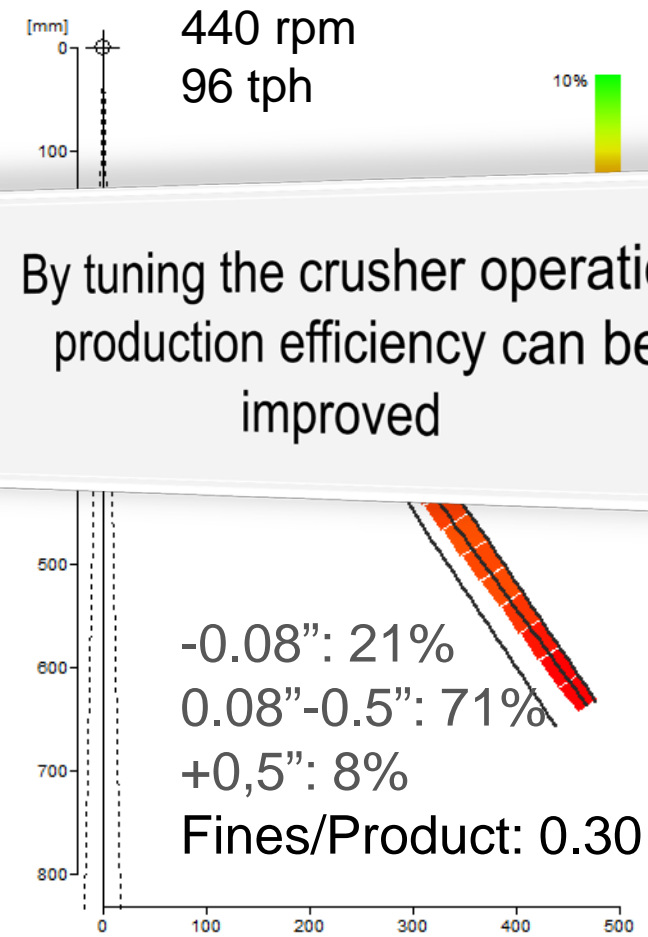
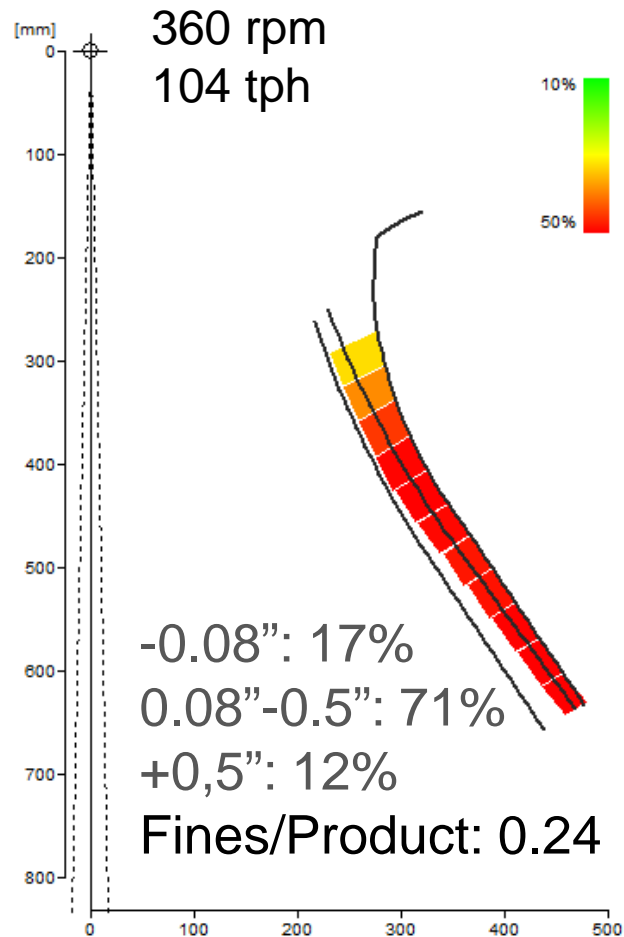
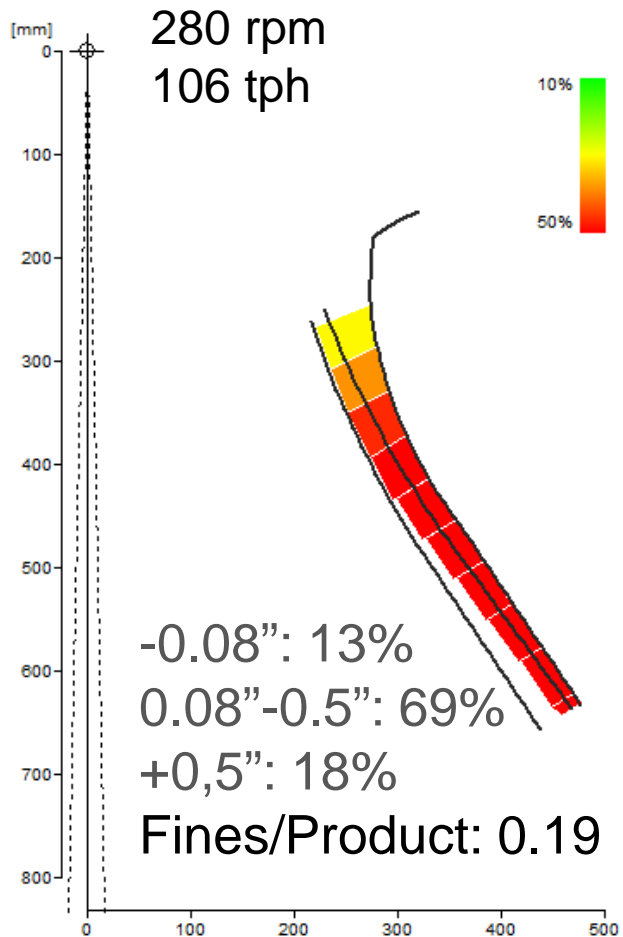

By tuning the crusher operation  
production efficiency can be  
improved

Changing speed can have mechanical effects on the crusher and motor

# Crusher Operation

- Relation between CSS and Shape
  - The size where the best shape can be found is at CSS
  - It is very difficult for cubical stones larger than CSS to pass the chamber
  - Breakage of stones creates flaky particles. Smaller flaky stones will more easily find its way through the chamber

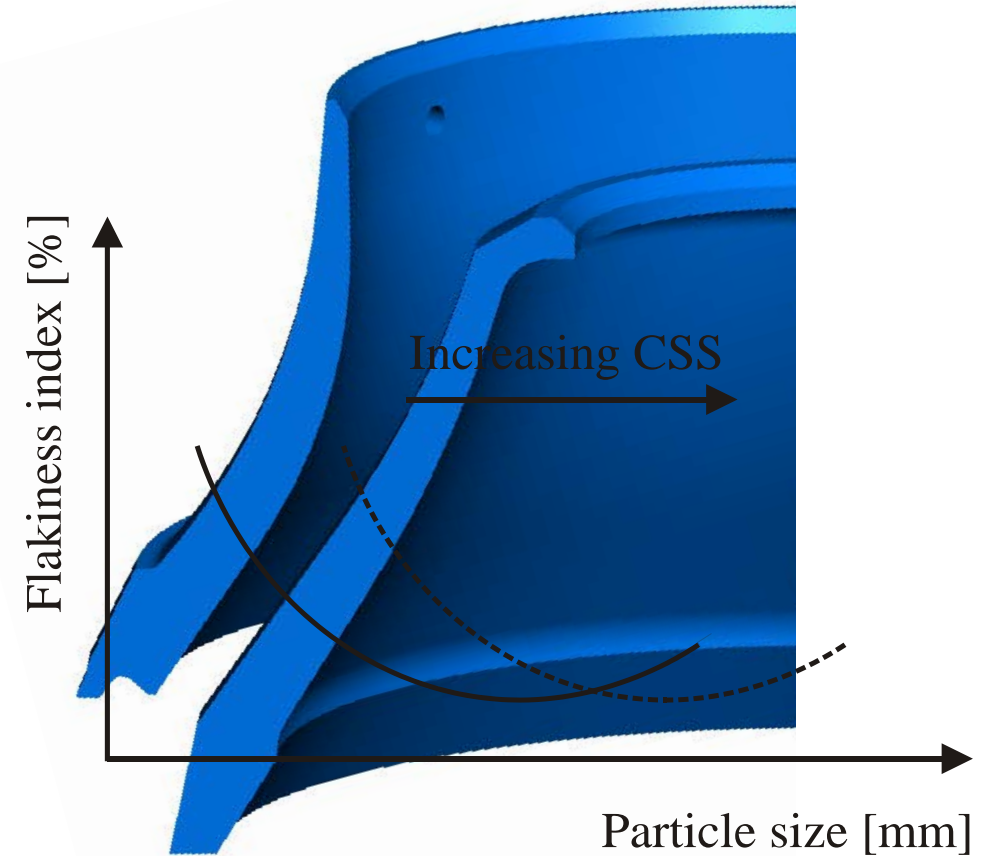

# Crusher Operation

- Relation between Feed size and Shape
  - The greater reduction ratio the worse particle shape.
  - Inter particle breakage improves shape. When crushing a bed of material weaker particles will break first. Flaky or elongated particles are weaker than round.
  - Breaking round particles gives flaky material.

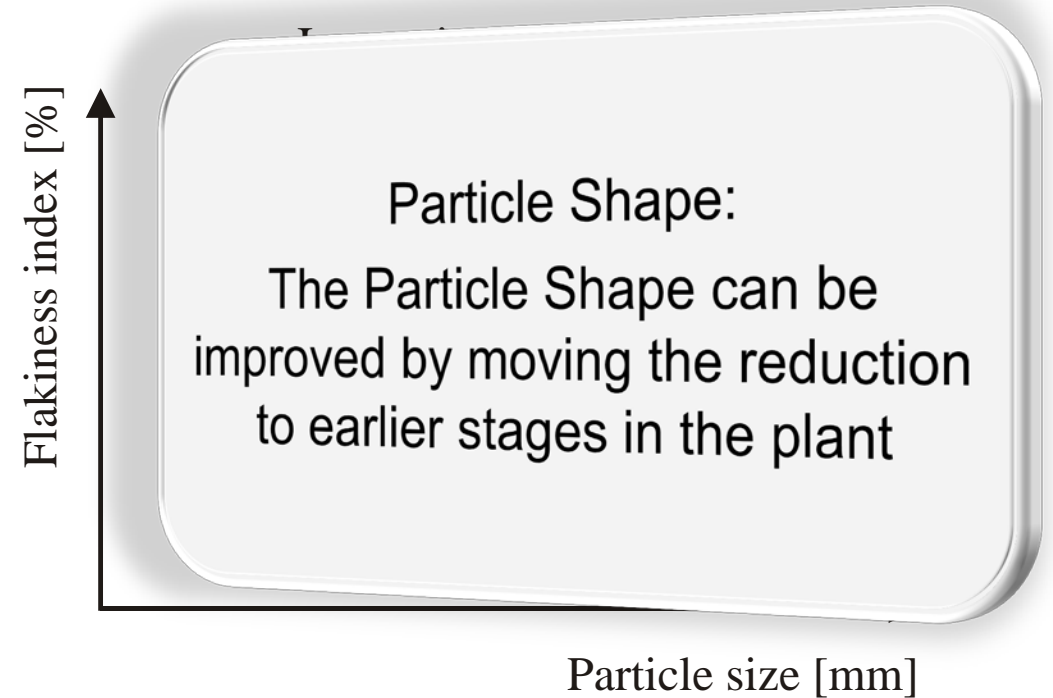

# Crusher Operation

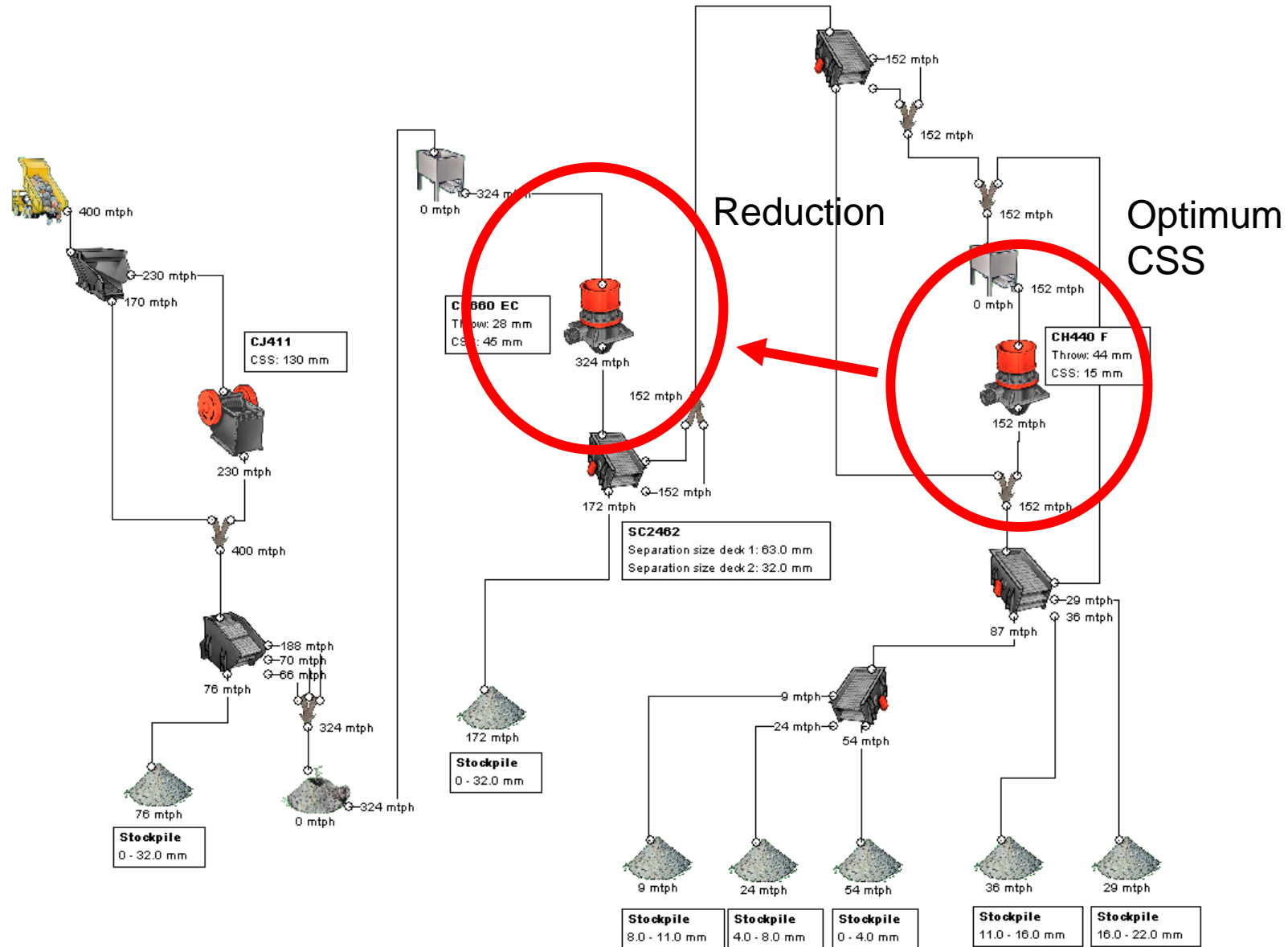



# Optimization of a Final Crushing Stage



- Who is control of your process performance?
- What tools have been provided to make the production efficient?
  
- Maximize crusher yield
  - Production of valuable products
  - Efficient production of current product demands
  
- *Crusher Performance Map* will help guide the crusher operator

# Optimization of a Final Crushing Stage



- This method applies to other crushers where a control variable is available
- The crushers are the last size reduction stage in the value chain.
- Over crushing is common.
- The connection between crusher setting and yield is often unknown
- The rock cannot be repaired.
- We need to control the crusher carefully.



# Optimization of a Final Crushing Stage

Planning

Sampling

Analysis

Optimization



- Optimization of one parameter (CSS) can be done by sampling and analysis
- The invested time and lost production will quickly be repaid by increased productivity
- Combine product yield and economic aspects
- This can be done by taking samples and making the analysis in MS Excel

# Optimization of a Final Crushing Stage

Planning

Sampling

Analysis

Optimization

- Material from crusher is sampled
- Measure the capacity at each crusher settings. CSS will effect the final product capacity, especially in a closed circuit.
- Production of 4 valuable products
  - 0.08-0.16" (2-4 mm)
  - 0.16-0.32" (4-8 mm)
  - 0.32-0.64" (8-16 mm)
  - 0.64-0.87" (16-22 mm)
- By-product with no value
  - 0-0.08" (0-2 mm)

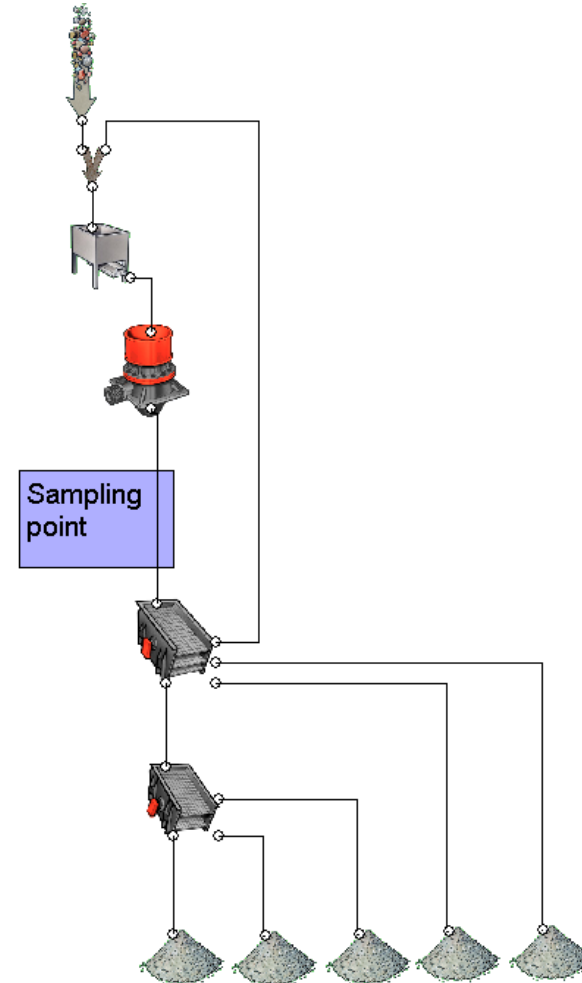

# Optimization of a Final Crushing Stage

Planning

Sampling

Analysis

Optimization

- Run the crusher at different settings
- Take at least one sample at each setting. (Multiple samples are often useful)
- Special Attention to Safety when taking samples!!
- Position of point where samples are taken.
- Ensure that the conveyor will not start by accident.



# Optimization of a Final Crushing Stage

Planning

Sampling

Analysis

Optimization

- Particle Size Distribution Plots
- If taking single samples on each CSS the risk of getting inconsistent results might make the graph look strange.
- Impossible to determine optimum setting by only using particle size distribution graphs

Particle Size Distribution for different CSS

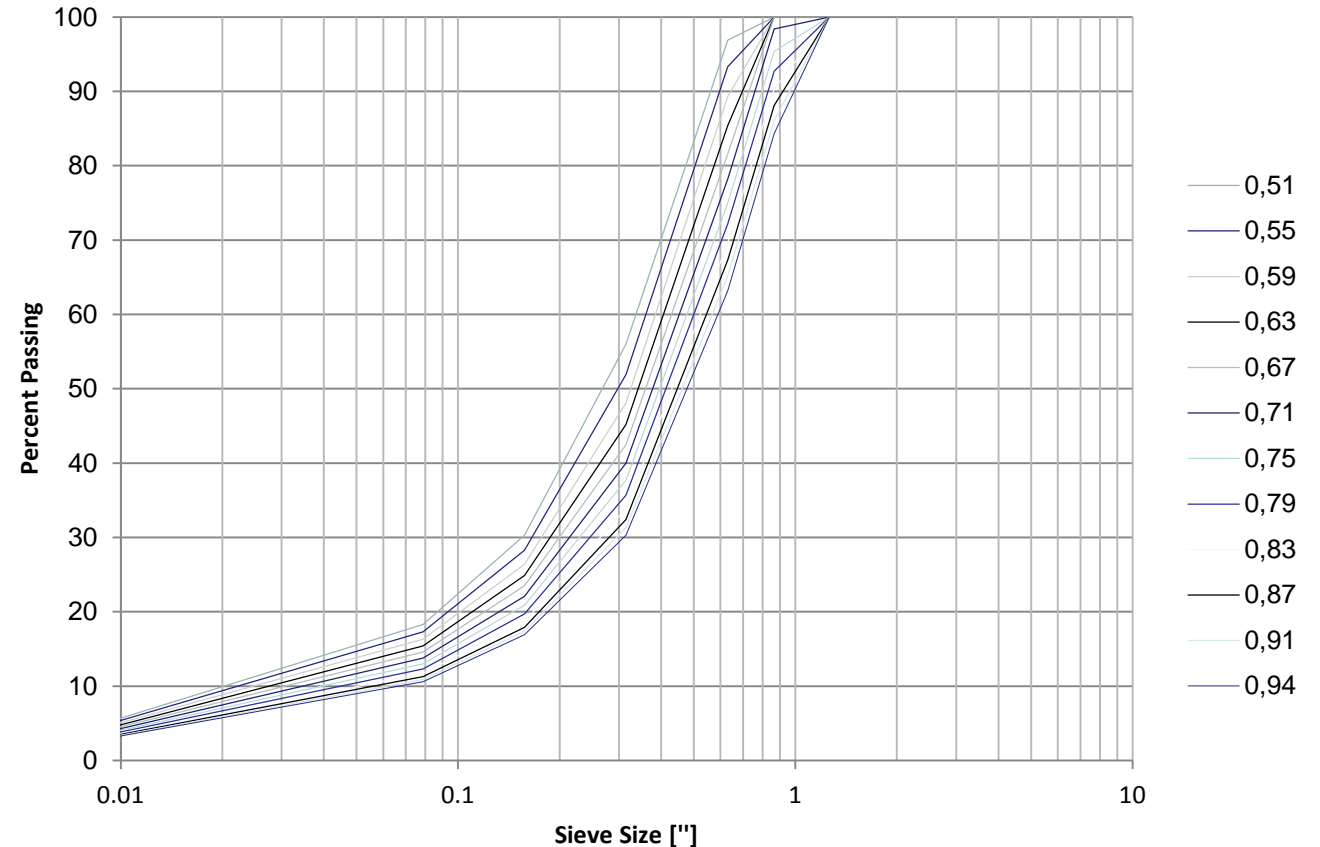



# Optimization of a Final Crushing Stage

Planning

Sampling

Analysis

Optimization

- If taking single samples on each CSS the risk of getting inconsistent results might make the graph look strange.
- Impossible to determine optimum setting by only using particle size distribution graphs

Capacity and CSS

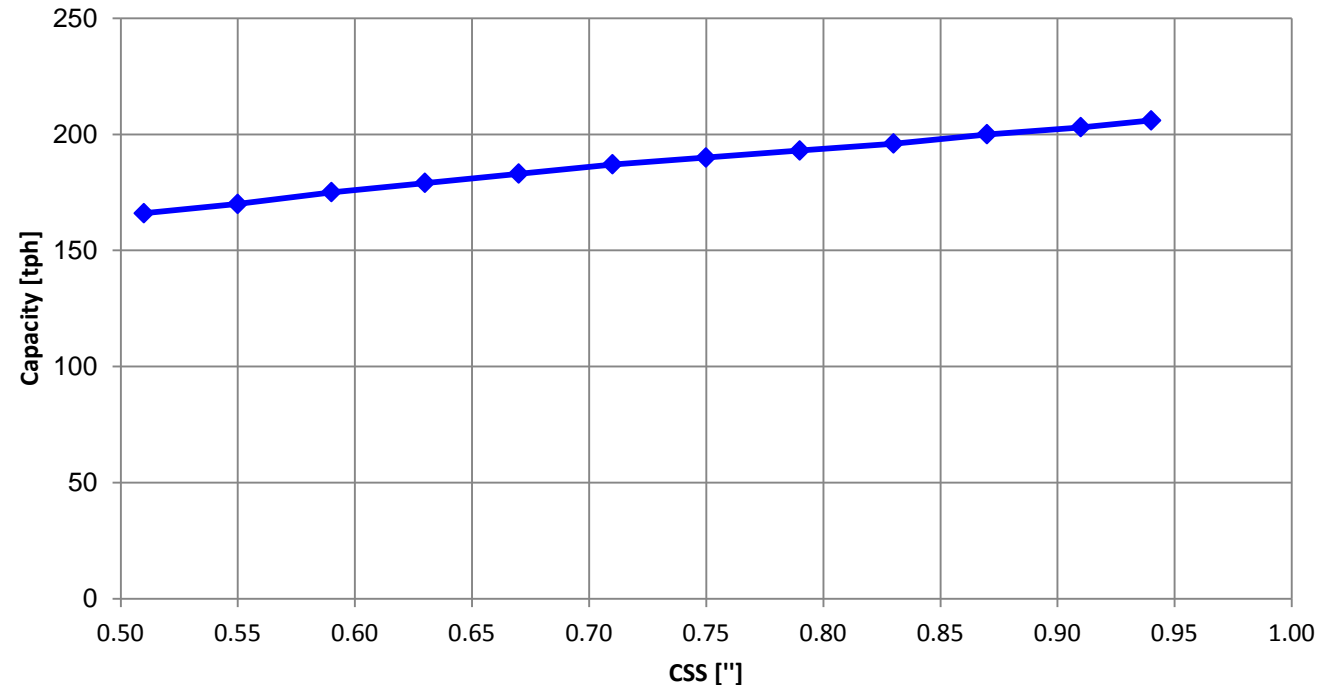

# Optimization of a Final Crushing Stage

Planning

Sampling

Analysis

Optimization

- Combine the particle size distribution and capacity.
- Percentage of final product times the capacity gives the production capacity of each product.

- Example 0.08''-0.16'' mm at CSS 0.79'':

- Percentage of crusher production
- $20\% - 11\% = 9\%$
- Crusher capacity
- 193 tph
  
- Total Production:
- $193 \text{ tph} \times 9\% = 17 \text{ tph}$

Capacity and CSS

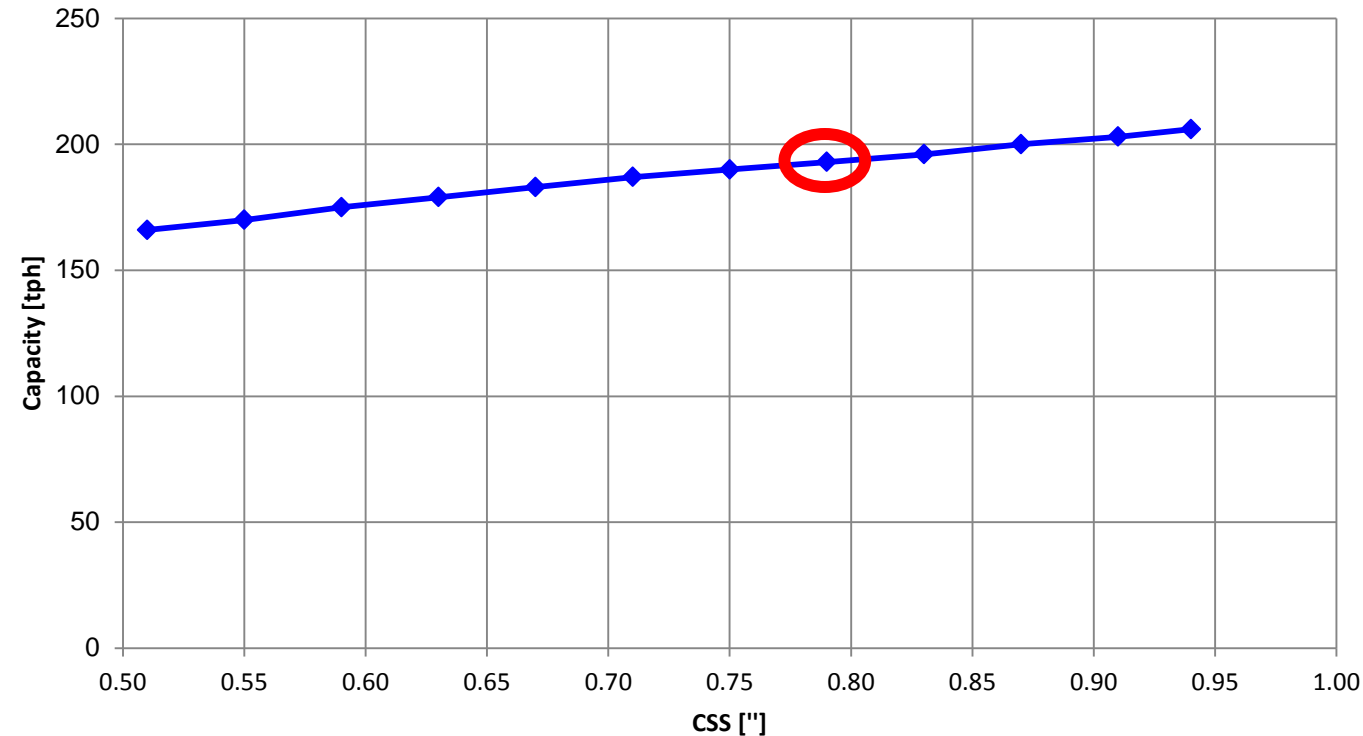

# Optimization of a Final Crushing Stage

Planning

Sampling

Analysis

Optimization

- Entering all the values into MS Excel makes this easy to get production capacities.
- Still difficult to determine the optimal setting

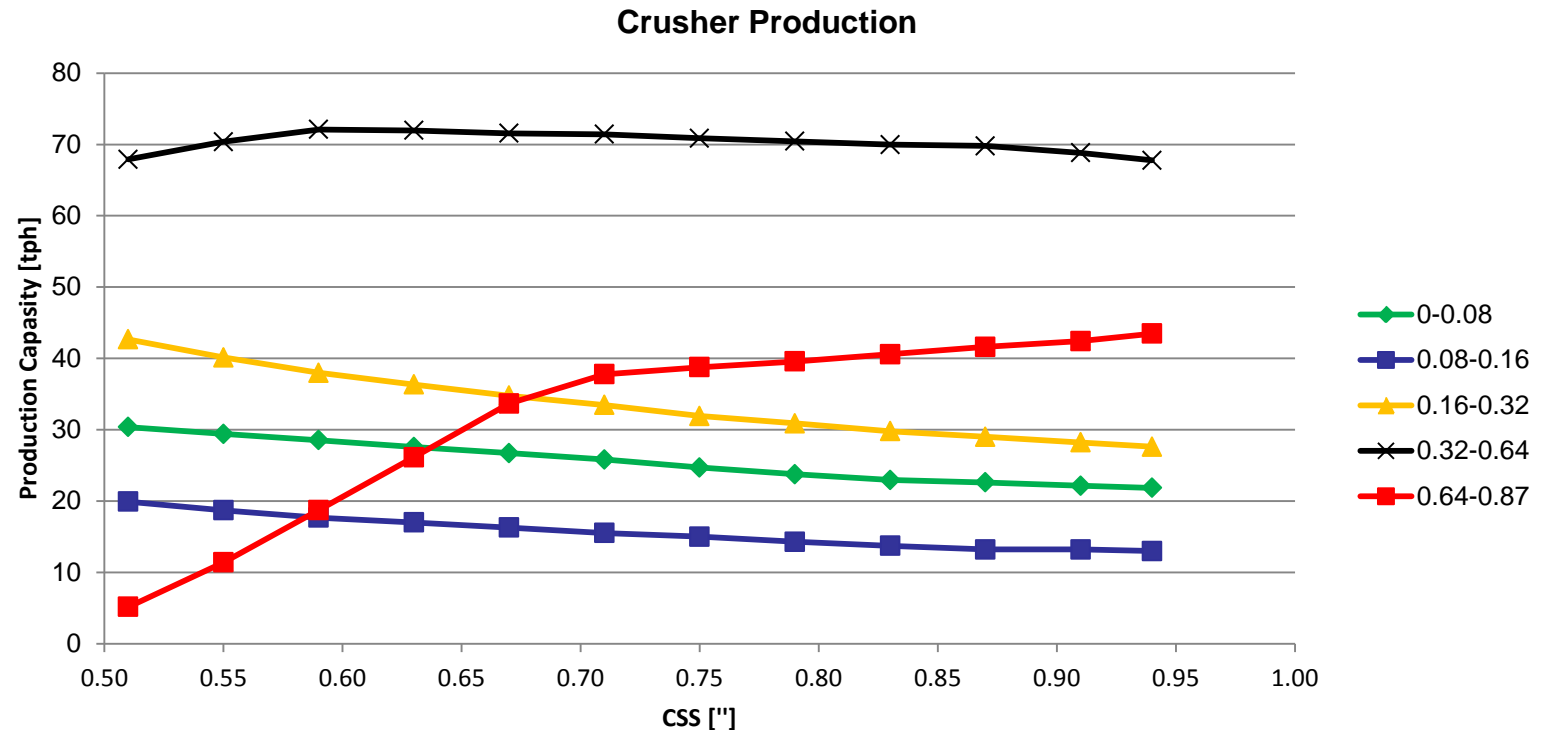

# Optimization of a Final Crushing Stage



Crusher Yield

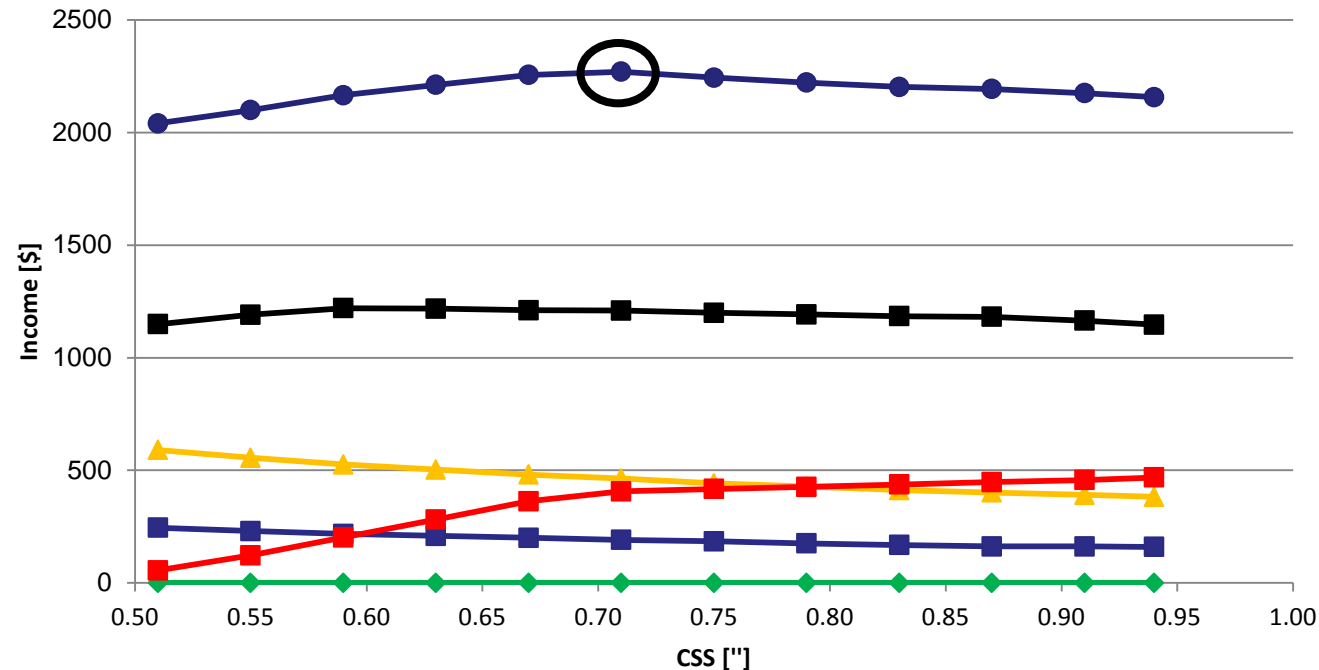

- Use the price\* per ton for all products:

- 0-0.08": \$ 0 (by-product)
- 0.08-0.16": \$ 12.30
- 0.16-0.32": \$ 13.85
- 0.32-0.64": \$ 16.90
- 0.64-0.87": \$ 10.80

- Make an income graph by combining prices with capacity

# Optimization of a Final Crushing Stage

Planning

Sampling

Analysis

Optimization

- What difference does it make?
- Running the crusher 0.08" off:
  - Decrease the profit by 58.5 \$/h
  - Running the crusher at 1600 hours per year:  
 $58.5 * 1600 = \$93600$

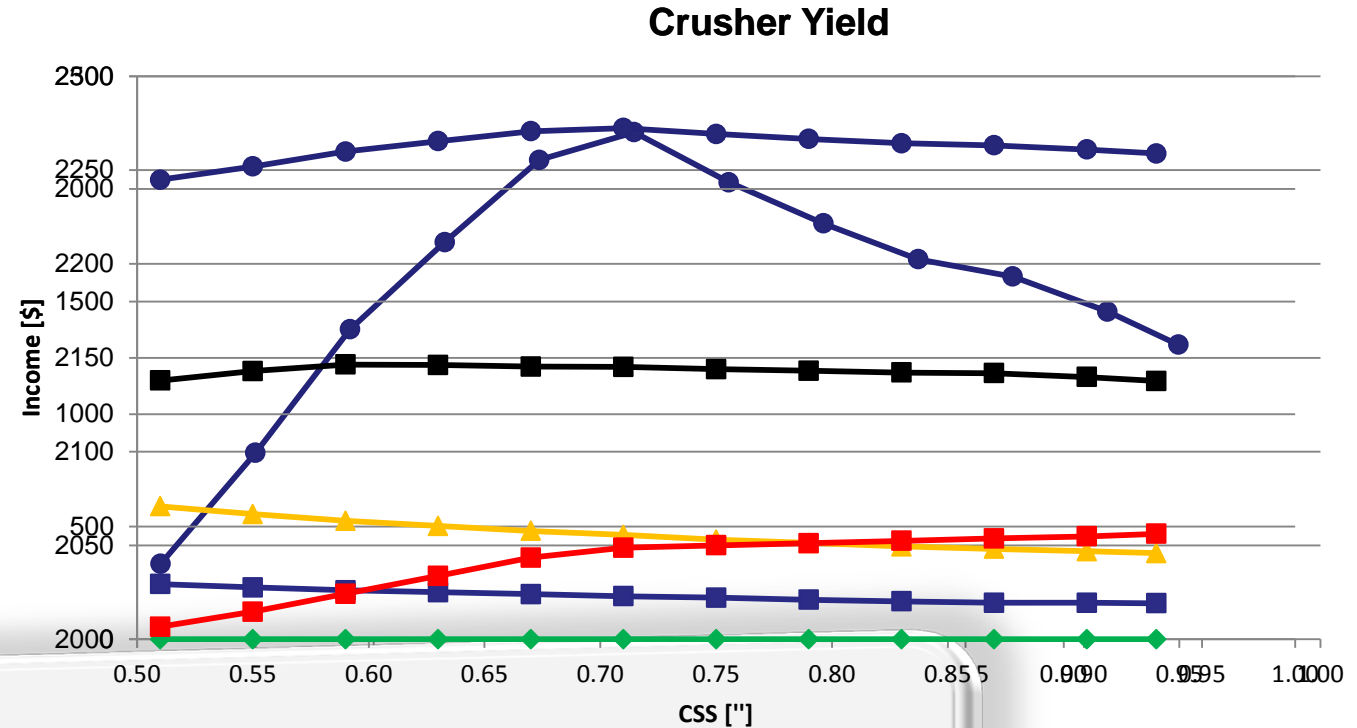

Optimization:  
 The effort put in to optimization will repay itself quickly

# Crusher Performance Map

Planning

Sampling

Analysis

Optimization

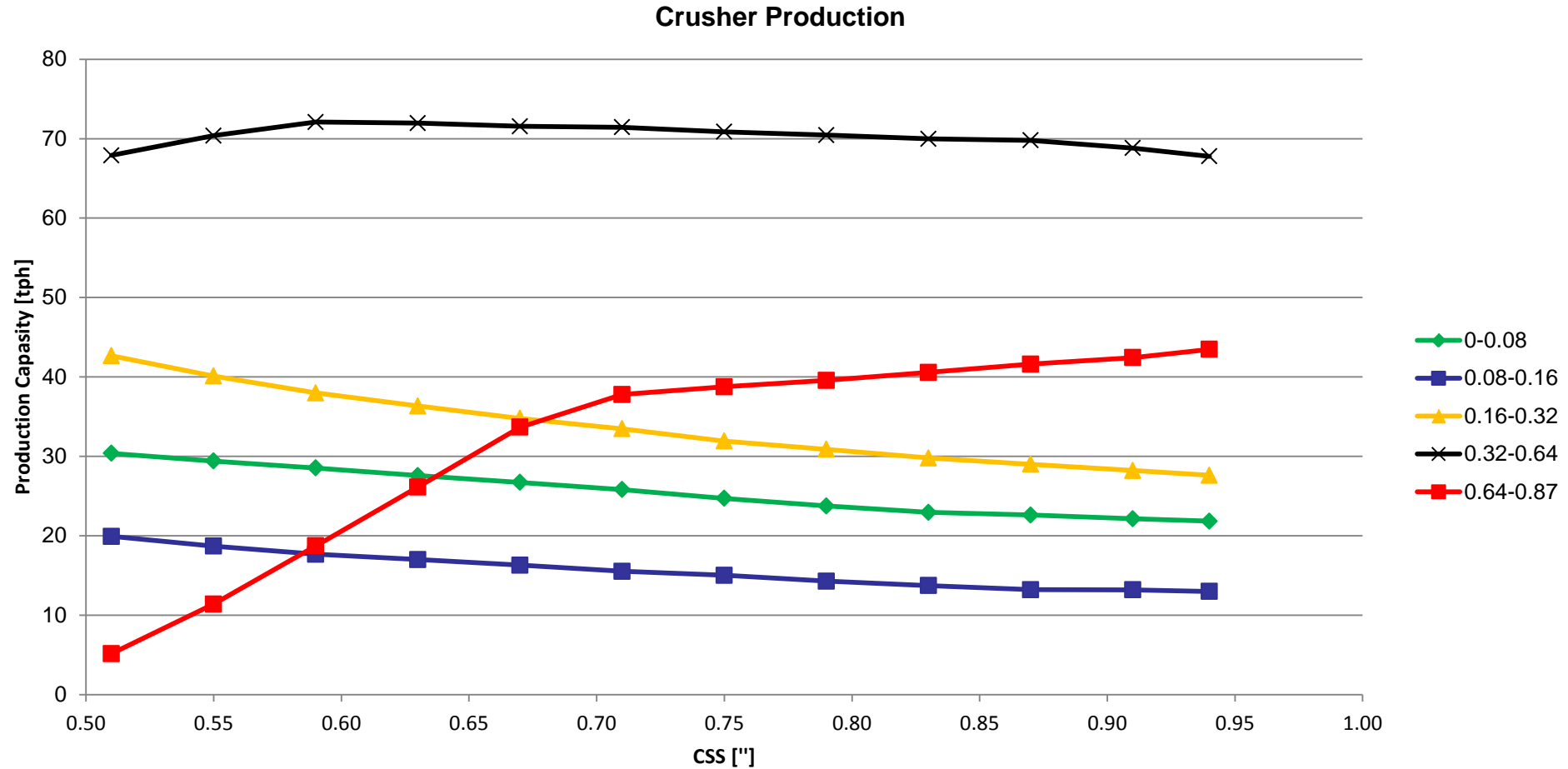



# Crusher Performance Map

- The general idea:
  - Select a crusher where you think optimization will be beneficial
  - Make a plan for what you would like to test
    - CSS, Speed, Curtain Position...
  - Run a sampling campaign
    - Particle size distribution, shape, capacity
  - Do the analysis
    - Convert test results into values of performance
  - Find the sweet spot

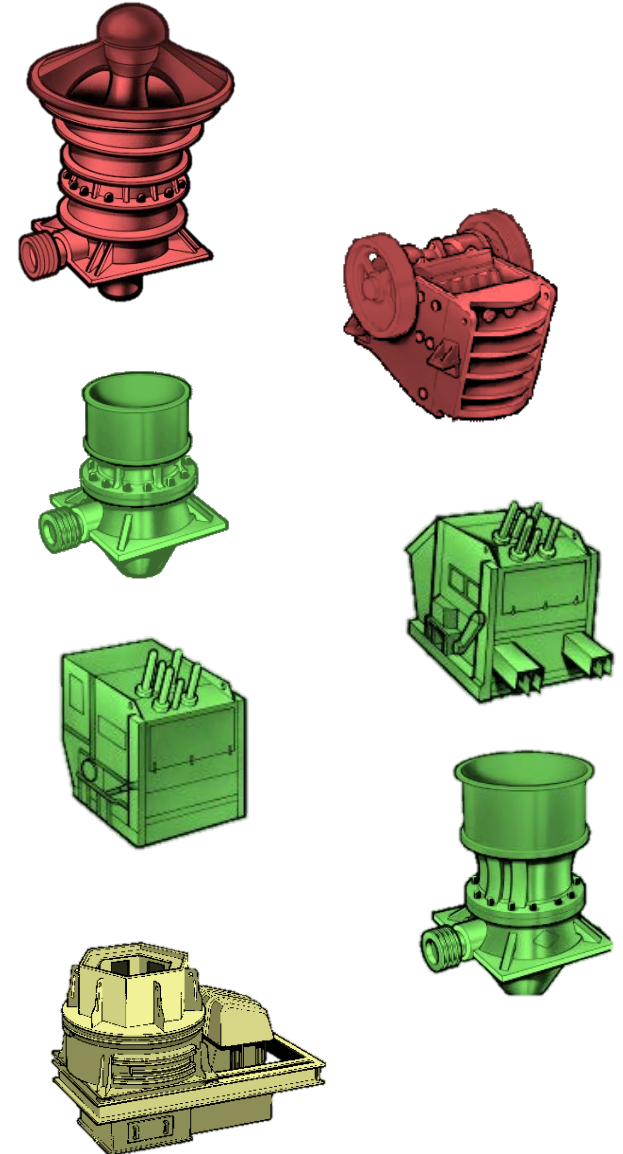

# Crusher Performance Map

The Crusher Performance Map can assist your operator with maintaining efficient production

Crusher Performance Map

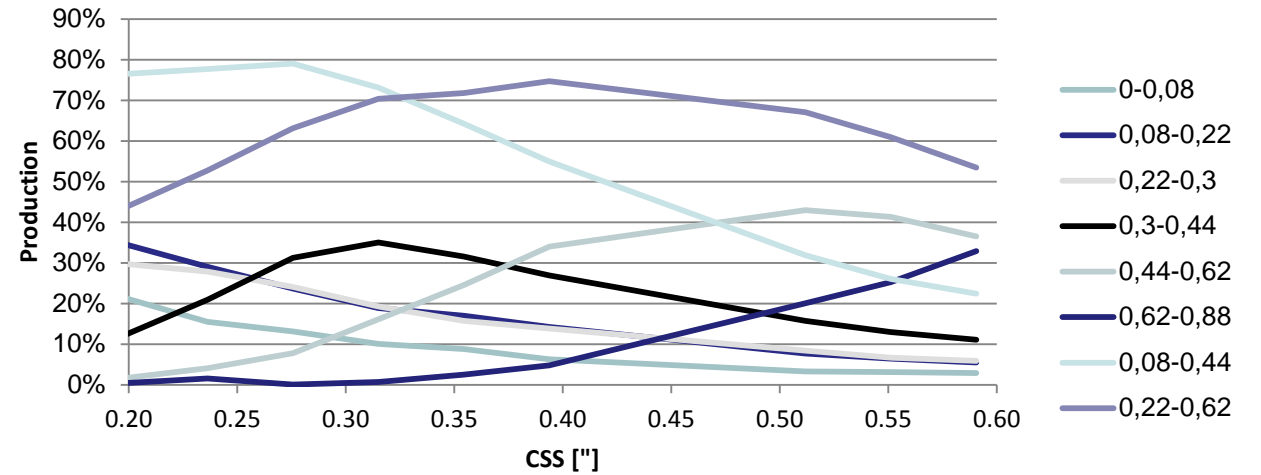

Crusher Performance Map

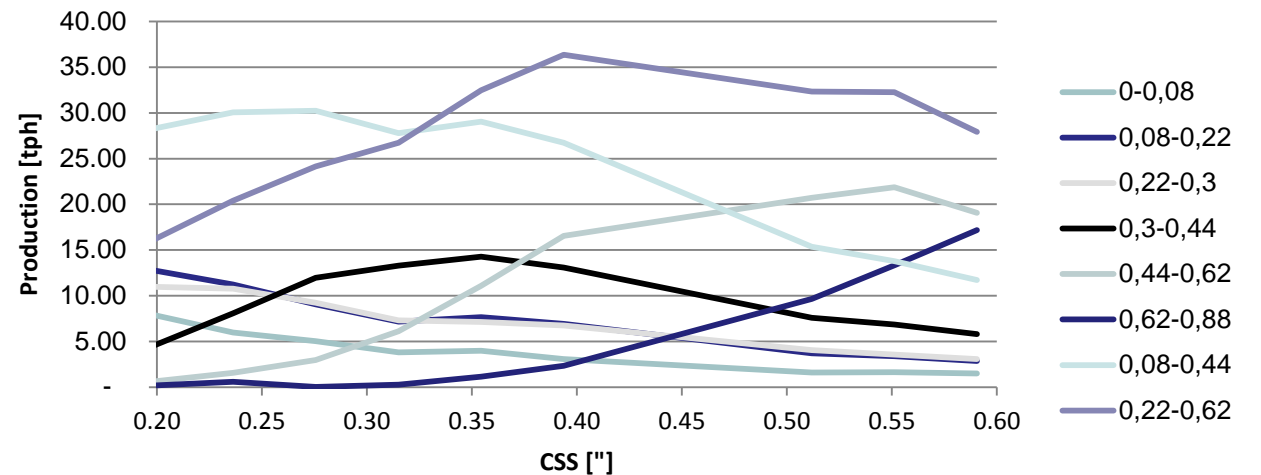

# Conclusions

Capacity is determined by the choke zone

By tuning the crusher operation production efficiency can be improved. Throw, Speed and Chamber Selection

The Particle Shape can be improved by moving the reduction to earlier stages in the plant and selecting correct CSS

Process Capacity and Crusher Capacity must correspond

The effort put in to optimization will repay itself quickly

The Crusher Performance Map can assist your operator with maintaining efficient production

[www.quarryacademy.com](http://www.quarryacademy.com)



Improving Processes. Instilling Expertise.