

Metalliferous Mining - Processing

Thickening

Resource Book

Table of Contents

TABLE OF CONTENTS	2
INTRODUCTION TO THICKENERS	3
<i>What is this module about?</i>	3
<i>What will you learn in this module?</i>	3
<i>What do you have to do to complete this unit?</i>	3
<i>What resources can you use to help?</i>	3
THICKENING	4
THICKENERS	5
COMPONENTS AND ACCESSORIES OF THICKENERS	7
FLOCCULATION	13
THICKENER OPERATION AND OPERATOR CONTROL.....	16
Torque & Doughnut Formation.....	17

Introduction to Thickeners

What is this module about?

This unit is about how we manage and use thickeners within the processing plant at SDGM

What will you learn in this module?

When you have completed this module, you will be able to:

- Define Thickening
- Describe how a thickener works
- Identify the two types of Thickeners
- List the different components and accessories of Thickeners
- Explain what is meant by the term flocculation
- Demonstrate an understanding of Thickener operation and operator control

What do you have to do to complete this unit?

You will need to complete all the training tasks in your workbook, the review exercise and the assessment given to you by your supervisor.

Discuss the competency standards for this unit with the Training Coordinator or your supervisor.

What resources can you use to help?

If you need more information about topics in this unit, then you should approach:

- Your work mates and supervisor
- The training coordinator
- Metallurgists

Thickening

Thickening Definition

Continuous thickening by an operation called sedimentation is the separation of suspended solid particles from a liquid stream by gravity settling. The primary purpose of thickening is to increase the solids concentration of the feed stream. Gravity settling is aided by addition of chemicals called flocculants. The inlet stream going to a thickener generally is called 'feed' or 'influent'. Overflow from the unit may be called 'overflow', 'effluent', or 'supernatant'. Underflow may be called 'pulp', 'sludge', 'slurry', 'mud', etc. The terminology will depend upon the industry application.

How a Continuous Thickener Works

As a feed stream enters the thickener, the solids settle to the bottom. Clarified liquor overflows to the top and settled solids underflow is removed from the bottom.

The following illustration shows a cross section, schematically illustrating the operation of a continuous thickener. The clear zone, which is the clear overflow liquor, is essentially free of solids in most applications. The hindered settling zone consists of a pulp of fairly uniform consistency, which is near the same solids concentration as the feed stream. The compaction zone shows the pulp in compression where dewatering occurs by compression of the solids forcing the liquids out of minute openings in the solids particles.

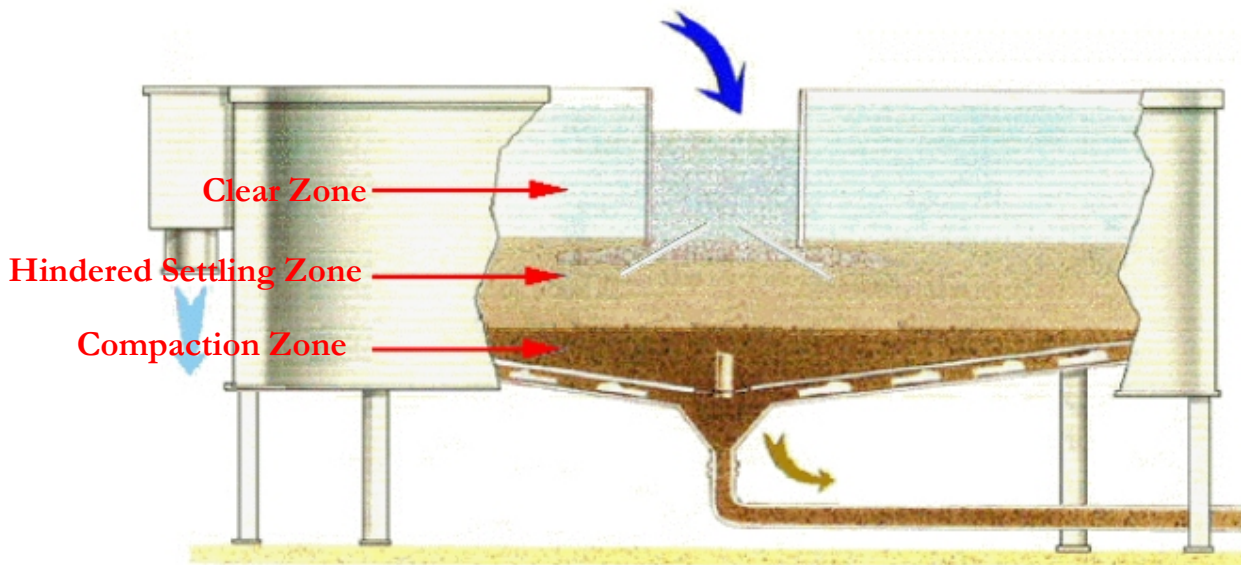

The following occurs in a continuous thickener:

Feed slurry becomes very diluted on entering the feed well and leaves the feed well as a dilute suspension from which particulate settling occurs. Considerable lateral movement occurs in the floc bed zone, i.e. particles are forced to the edges of the thickener. Further liquid entering into the feed well sustains this dilution effect. The floc particles agglomerate and settle to the surface of the thickening pulp, and continue to concentrate in this zone until underflow density is reached.

Thickeners

A thickener has several basic components: a tank to contain the slurry, feed piping and a feed well to allow the feed stream to enter the tank, a rotating rake mechanism to assist in moving the concentrated solids to the withdrawal points, an underflow solids withdrawal system, and an overflow launder.

Continuous thickeners have undergone several modifications that have resulted from the development of a wide variety of organic polymeric flocculants. As a result, there are now two basic types of continuous thickeners: Conventional and High-rate.

Conventional Thickeners

These thickeners differ in the way they are built. Some examples of basic differences are:

- Bridge supported
- Center column supported
- Traction drive

The feed stream is brought to the center of the thickener in a pipe or open launder and enters the feed well, which is designed to minimise turbulence resulting from the feed entry velocity and to force the entering slurry below the clear-liquid surface.

The thickened solids flow and are raked to the center of the thickener and removed. The overflow liquid is removed from the thickener in a peripheral launder. The conventional thickener relies on the settling velocity of the particles, due to gravity, being greater than the upward velocity of water being displaced to the overflow launder. The conventional thickener can be used with or without flocculants, depending upon the application. If employed, flocculants are normally added to the feed launder or in the feed well, and flocculation occurs in the resulting turbulence.

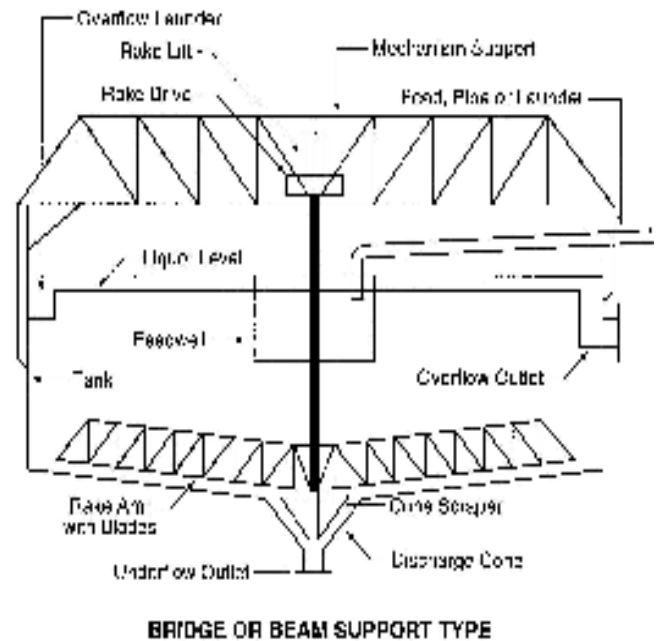

High Rate Thickeners

High rate thickeners are designed specifically to maximise the flocculation efficiency of flocculants. They differ from conventional thickeners in feed well design, size and control. Unlike conventional thickeners, high rate thickeners must use flocculants. The basic design of a high rate thickener is below.

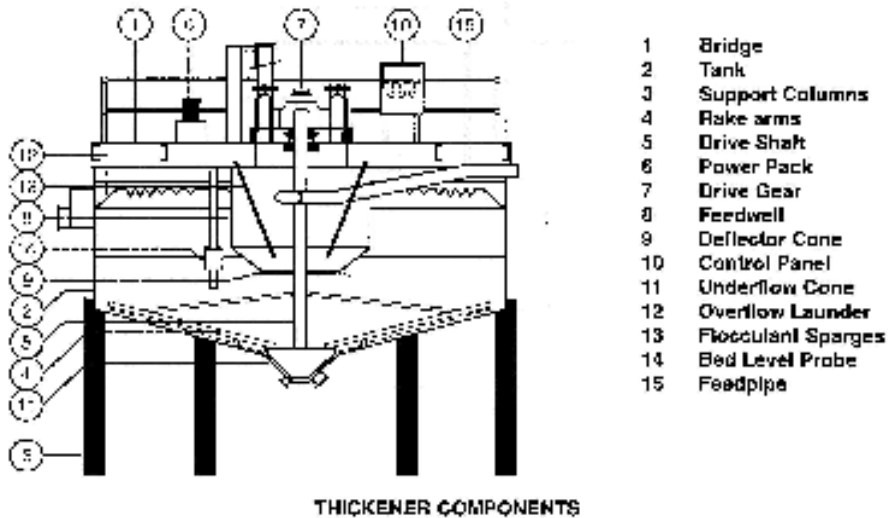

High rate thickener feed wells are designed to disperse flocculants thoroughly into the feed end to admit the flocculated slurry into the settling zone of the thickener without destruction of the newly formed floccules. The feed may enter into the sludge bed if the flocculation must be completed by the solids-contact means, or it may enter above the pulp level if it is sufficiently flocculated to produce the desired clarity and the underflow density.

The increase in flocculation efficiency realised in high rate thickeners may increase in a bulk settling rate 2 to 10 times over that obtained in a conventional thickener, thus reducing the unit area requirements by a similar factor. The corresponding volume may be 4 to 15 times smaller than with conventional thickeners in the same application.

As a consequence, change in the solids feed rate or the settling characteristics of the solids will change the sludge level much more rapidly, therefore, high rate thickeners require some form of automatic control.

The control parameters used to maintain stable operation in high rate thickeners are underflow solids density, underflow withdrawal rate, flocculant dosage, solids inventory in the tank, solids feed rate, and mechanical torque limit restriction of rotating rake arm mechanism

Components and Accessories of Thickeners

A thickener consists of a collection of components, which can be supplied in a number of variations. The basic components are the same:

- Tank
- Drive Support Structure
- Drive Unit and Lifting Device
- Rake Structure
- Feed Well
- Overflow Arrangement
- Underflow Arrangement
- Instrumentation and Flocculation Facilities

Tanks

Tanks or Basins are constructed of such material as steel, concrete, wood, compacted earth, plastic sheeting, and soil cement. The selection of the materials of construction is based on cost, availability, topography, water table, ground condition, climate, operating temperature and chemical corrosion resistance. Typically, industrial tanks up to 30m in diameter are made of steel.

Drive Support Structure

Bridge supported thickeners are common in diameters of 30m, the maximum being 45m. They offer the following advantages over other thickeners:

Ability to transfer loads to the tank periphery;

- Ability to give a denser and more consistent underflow concentration with a single draw off point;
- A less complicated lifting device;
- Fewer structure members subject to mud accumulation;
- Access to the drive from both ends of the bridge; and
- Lower cost for units smaller than 30m in diameters.

Drive Assemblies

The drive assembly is the key component of a thickener. The drive assembly provides:

- The force to move the rakes through the thickened pulp and move settled solids to the point of discharge.
- The support mechanism which permits it to rotate.
- Adequate reserve capacity to withstand upsets and temporary overloads.
- A reliable control which protects the mechanism from the damage when a major overload occurs.

The drive typically provides a torque measurement that is indicated on the mechanism and may be transmitted to a remote indicator.

If the torque becomes excessive, it can automatically activate such safeguards against structural damage as sounding an alarm, raising the rakes, and stopping the drive. Drives may be mechanical or hydraulic.

Rake Lifting Mechanism

These should be provided when abnormal thickener operation is probable. Abnormal thickener operation or excessive torque may result from insufficient underflow pumping, surges in the solids feed rate, excessive amounts of large particles, sloughing of the solids accumulated between the rakes and the bottom of the tank or on structural members of the rake mechanism, or miscellaneous obstructions falling into the thickener. The lifting mechanism may be set to raise the rakes automatically when a specific torque level (eg 50% of design) is encountered, continuing to lift until the torque returns to normal or until the maximum lift height is reached. Generally, corrective action must be taken to eliminate the cause of the upset. Once the torque returns to normal, the rake mechanism is lowered slowly to 'plough' gradually through the excess accumulated solids until these are removed from the tank.



Drive Assembly & Rake Lifting Mechanism

Rake lifting devices can be manual for small diameter thickeners or motorised for larger ones. Manual rake lifting devices consist of a hand wheel and worm to raise or lower the rake mechanism by a distance usually ranging from 30 to 60cm. Motorised rake lifting devices typically are designed to allow for a vertical lift of the rake mechanism of up to 90cm.

Rake Mechanism

The rake mechanism assists in moving the settled solids to the point of discharge. It also aids in thickening the pulp by disrupting bridged floccules, permitting trapped fluid to escape and allowing the floccules to become more consolidated. Rake mechanisms are designed for specific application, usually having two long rakes with an option for two short rake arms.

Feed Well

The feed well is designed to allow the feed to enter the conventional thickener with minimum turbulence and uniform distribution while dissipating most of its kinetic energy. Feed slurry enters the feed well, which is usually located in the centre of the thickener, through a pipe or launder suspended from the bridge.

To avoid excess velocity, an open launder normally has a slope no greater than 2/100. Pulp should enter the launder, suspended from the bridge, at a velocity that prevents sanding at the inlet. The standard feed well for conventional thickeners is designed for a maximum nominal flow velocity of 1.5 m/min.

High turbidity caused by the depth of the feed well. When overflow clarity is important or the solids gravity is close to the liquid specific gravity, deep feed wells of large diameter are used. Shallow feed wells may be used when overflow clarity is not important, the overflow rate is low, and or the solids density is appreciably greater than water.

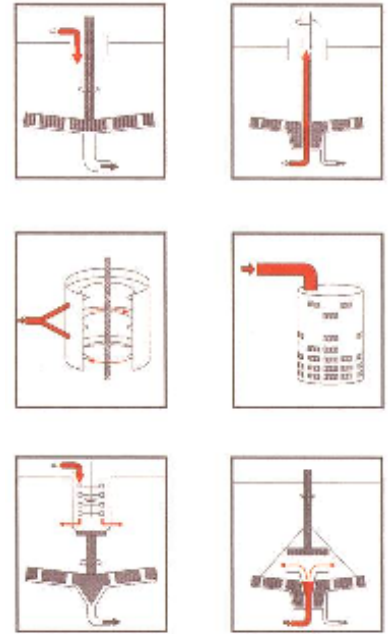

Distributor Cone



Feed Well & Distributor Cone

The distributor cone is mounted directly below the feed well. The purpose of the distributor cone is to distribute flocculated slurry to the outside edge of the tank.

The cone angle promotes an even distribution of the flocculated solids. A gap exists between the distributor cone and feed well pipe. This reduces the velocity and turbulence of the solids entry into the pulp bed.

Overflow Arrangements

Clarified effluent typically is removed in a peripheral launder located inside or outside the tank. The effluent enters the launder by overflowing a 'V' notch or level flat weir. Uneven overflow rates caused by wind blowing across the liquid surface in large thickeners can be better controlled when 'V' notch weirs are used. The hydraulic capacity of a launder must be sufficient to prevent flooding, which can cause short-circuiting of the feed and deterioration of overflow density.

Underflow Arrangements



Cone and Pinch Valve Arrangement

Concentrated solids are removed from the thickener by use of a centrifugal slurry pump, positive displacement pump or by gravity. The underflow arrangement must be designed to remove solids, without plugging upsets, at the maximum rate at which they will enter the thickener. Provisions must be made to unplug or to bypass plugged piping so that solids can always be removed from the thickener to preclude their filling the thickener and stalling the mechanism. Underflow recycle back to the feed well is used in some

applications to aid in flocculation of the unit during periods when the feed is reduced or interrupted.

These are two basic under flow arrangements and are as follows:

- Tunnel
- Centre cone pumping (open area)



Bed Level Probe

Instrumentation

Instrumentation is used on most thickeners to measure torque in order to prevent mechanical damage to the drive or rake mechanism by actuating a rake lifting device or shutting off power to the drive in the event of an overload. Some applications also require automatic control of thickener feed or discharge to maintain acceptable performance when departure from the norm occurs. One example is the high rate thickener, which must have some degree of automation for efficient normal operation.



This is not difficult to provide, for high rate thickener is characterised by a relatively short time lag between a process change and the effect of the change; control by conventional instruments or minicomputers therefore is feasible. Automatic control of conventional thickeners, on the other hand, is more difficult because of the longer lag between process change and effect. In addition to drive torque and rates of feed and underflow, other process variables that can be

controlled to advantage in some applications are flocculant dosage, underflow solids concentration, solids-liquids interface heights, and overflow clarity. Underflow pumping control is sometimes used to control two of these: bed pressure and underflow solids concentration.

An approximately steady state material balance must be maintained around the thickener. Although the volume of pulp in the thickener can be allowed to increase or decrease within harmless limits, it must be controlled to prevent, on the one hand, solids from overflowing the thickener and, on the other hand, the bed pressure from falling so low that the underflow density drops below desired values. Variable pumping rates can be obtained by use of variable speed pumps or flow control valves. Underflow density measurements can be made by routine checks using a device like a Marcy pulp density scale by the operator or on line through use of a density gauge.

T H I C K E N I N G

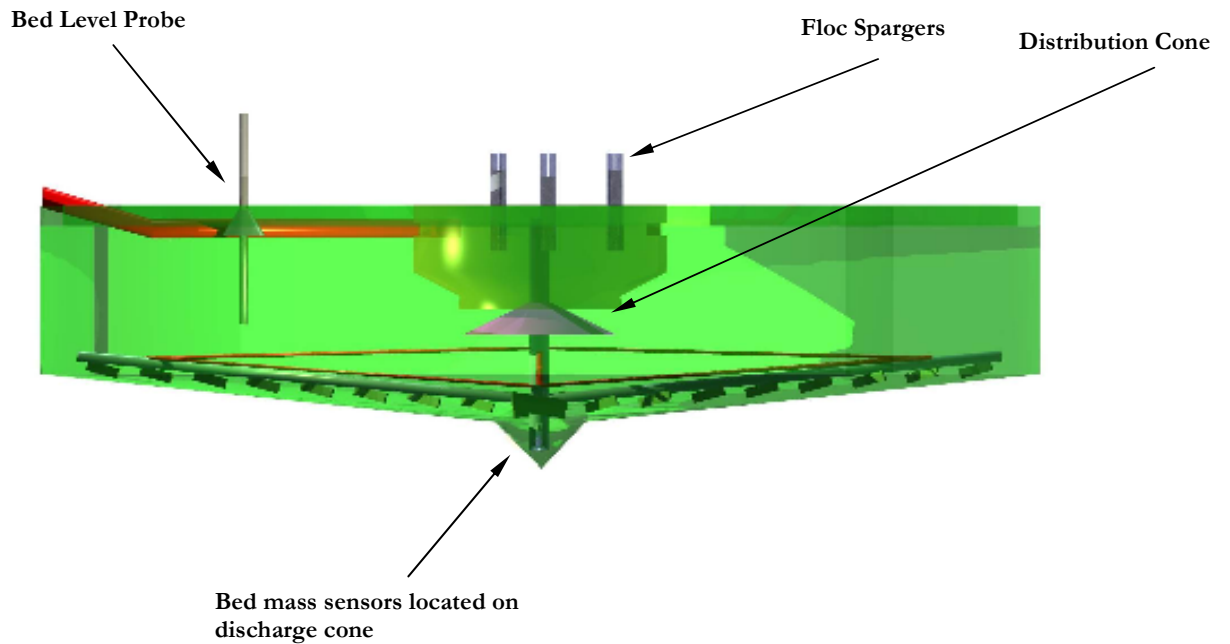
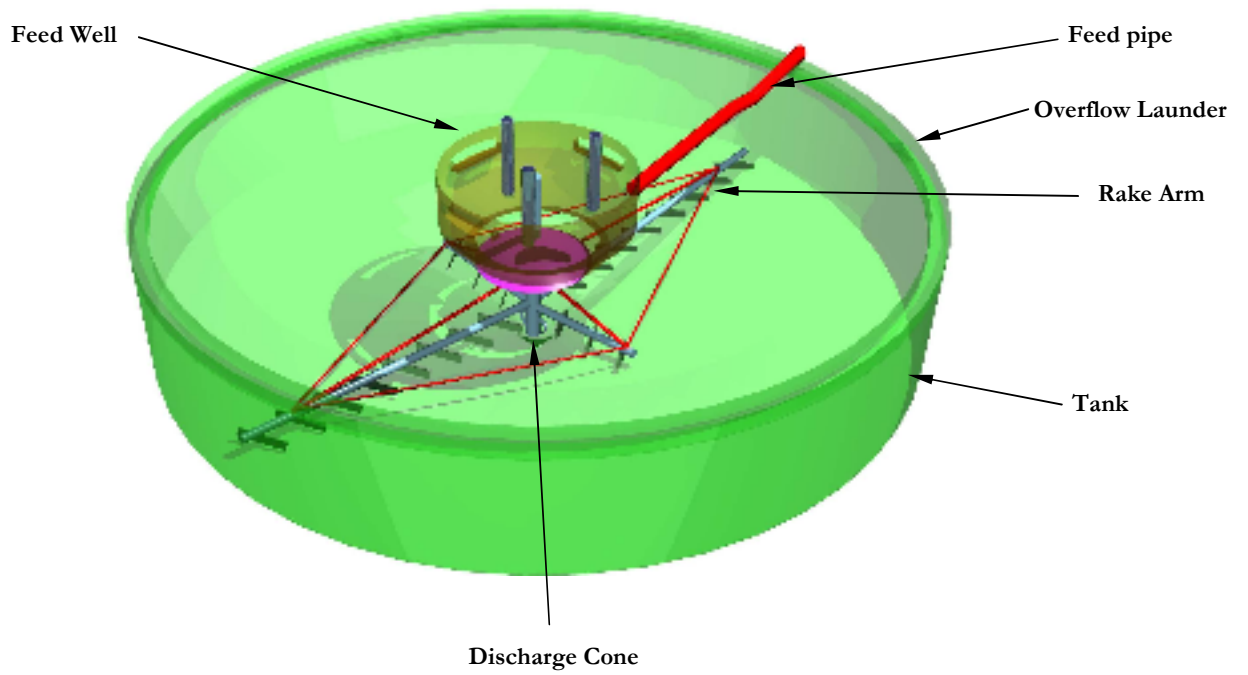

Turn to your workbook and complete Training Task 1 to 3

Flocculation

Thickener Operational Dynamics

A thickener is a dynamic device (ie what goes in must come out). It must operate in a steady state condition.

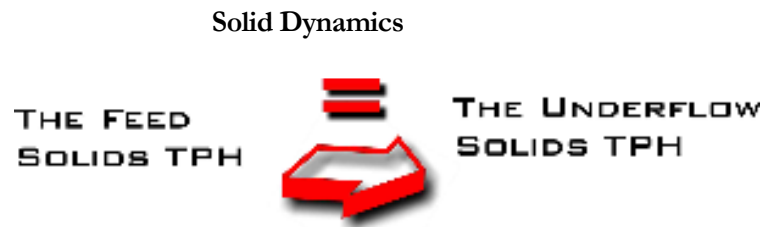
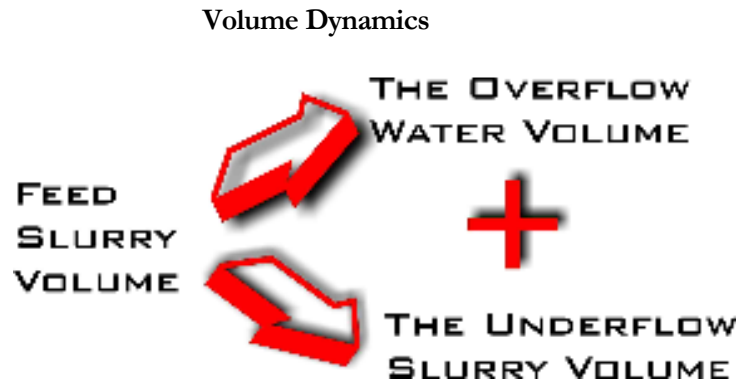

To understand thickener operation an understanding of how an individual agglomerated particle behaves is necessary.

Two forces act upon an agglomerated particle, these are:

- Gravity Force
- Buoyancy Force (the force of the rising water).

Gravity is of course the force that the earth exerts on every object. The bigger the object the larger effect the gravity force will have (ie bigger particles or small particles with very high SG's will settle faster).

The buoyancy force on a particle in a thickener is a little more complex and must be understood by technicians to competently operate the thickener.

Remember the feed volume (not feed solids) that is put into the thickener is far greater than the underflow volume withdrawn. Hence the thickener must overflow.

This concept can be easily understood with a simple example.

Buoyancy Force - Example

Imagine a plastic coffee cup with a small hole in the base. If placed under a slowly running tap, the rate at which water discharges out of the hole in the base may be enough to keep the cup only half full. However if the tap is turned on full, the cup will rapidly overflow because water cannot escape fast enough through the hole in the bottom. The force of the water rising and overflowing the cup is the main component of the buoyancy force.

Buoyancy force is mainly dependent on the feed volume flowrate and the size of the thickener.

Flocculation

Flocculant is a chemical designed to increase particle-settling rates in a thickener. Flocculant causes a number of small individual particles to join together to form an agglomerate which settles much faster. Correct flocculation is the single most important factor in the operation of a high rate thickener. The amount of flocculant added to the thickener is dependent on the ore. Harder ores will tend to have a coarser size distribution. They will require less flocculant, as individual particles are heavier and settle faster. Soft clay ores will tend to have a very fine size distribution. They will require larger flocculant additions as individual fine particles settle very slowly.

Flocculant Action

The schematic below shows the long chain negatively charged flocculant molecule combining with the positively charged ore particles to agglomerate and form a heavier colloid, which settles faster.

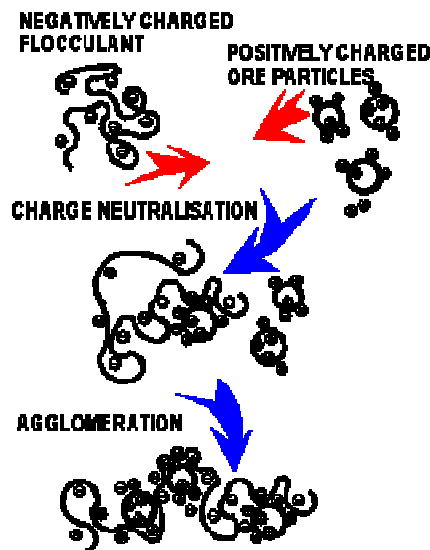

Flocculant Characteristics

Flocculation performance is usually increased with dilute slurry as it gives the flocculant more space to contact and agglomerate the finer particles. The slurry feed to the thickener is usually further diluted with extra water in the feed box. This dilution water is recovered straight away by the thickener overflow.

Flocculant is a long weak-chain molecule and is easily destroyed. Care must be taken not to subject flocculant or flocculated slurries to excessive agitation or turbulence. Agitation may be from a fast spinning agitator, a centrifugal pump impellor, a turbulent slurry pipe or box section, high pressure water injection etc. If the flocculant particle chains are broken (ie effectively shortened) the flocculant will not be able to bind many particles together and the settling rate of the ore in the thickener will decrease.

Settling

The path an agglomerated particle will take when it is introduced into the thickener is mainly dependent on flocculation. This is shown in the diagram below.

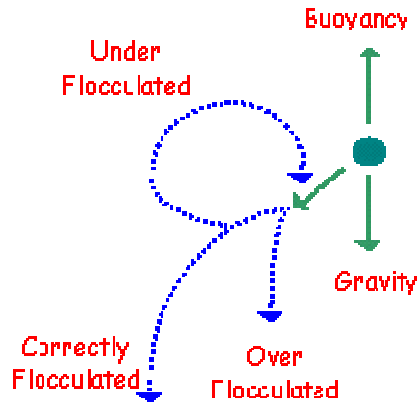

If the feed particles are not flocculated then it is probable that the buoyancy force will carry them upward to the overflow stream. This will cause the bed level to rise. Correctly flocculated particles will settle to the base of the thickener and allow clear overflow. Over flocculated feed will sink rapidly and may bog up the thickener rakes (waste of flocculant).



Turn to your workbook and complete Training Task 4

Thickener Operation and Operator Control

Thickener Operation

A thickener is a machine with a limited function. It is important to realise that a thickener is not just a 'pass through' device. It must be operated and controlled within specified limits if the required end result is to be obtained. Selection of the proper operating procedures or control method requires an understanding of how the unit functions and the importance of the variables involved

Thickener Operation Rules

INPUT minus OUTPUT equals ACCUMULATION.

Excessive accumulation results in operating problems, usually requiring shutdown
and

clean out = DISASTER.

These two statements are so simple that they should not require emphasis, yet a majority of thickener operation problems are a result of a lack of understanding of these basic rules. If solids are allowed to accumulate in a thickener without corrective action, one or more of the following will occur:

- The pulp will begin to exit the tank with the overflow.
- The underflow will become too thick to pump.
- A 'doughnut' will form in the thickener and the underflow density will start to approach the feed density.
- The rake mechanism will become overloaded and be stopped by the drive control.

The seriousness of the above is related to the characteristics of the solids which are handled. Coarse solids will usually overload a mechanism. Coarse solids, 840 to 250 microns, should generally be kept out of a thickener. However, there are circumstances under which these solids can be handled.

Solids in this size range produce a very high rake armload and require significant torque to transmit them to the discharge point. As the inventory of coarse solids increases the torque requirement rises rapidly.

Operator Control

That which occurs inside the thickener is not obvious to visual observation. The operator must rely upon representative (continuous is best) measurement of:

- Bed pressure. Increasing pressure is indicative of accumulation, due to insufficient underflow withdrawal.
- Feed. Density, size distribution, and quantity of solids.
- Underflow. Density, size distribution, and quantity. Solids in the feed are expected to report to the underflow.
- Torque. Increasing torque indicates overload may be occurring.
- Flocculant dosage mix.
- Position of rake arms with respect to normal elevation, if lift device is employed.

Interpretation of the meanings of these measurements provides the operator with action required to stay out of trouble. Each installation has its own operating peculiarities. Some of the generalities for mineral processing applications are:

Torque & Doughnut Formation

An increase in torque is usually the result of an increasing quantity of coarse materials in the slurry and on the tank bottom, and may be accompanied by a rise in pulp level and increased underflow density requiring a bulldozing action by the rake arms. Corrective action is to get the coarse material out, increase underflow withdrawal rate, and, if possible, increase mechanism speed if corrective action appears to require more time to prevent rake arm stoppage, raise the mechanism until the torque decreases - provided a lift is incorporated.

An increase in torque associated with a decrease in underflow density may be the result of 'doughnut' formation of the solids.

The general tendency when operating a thickener is to decrease the rate of underflow withdrawal as the density decreases, but this move may work in favour of increased doughnut formation. As a doughnut forms there is often an increase in drive torque due to the viscous drag through the slurry and the friction between the doughnut and the bed beneath the rakes.

An increase in torque indication together with decreasing underflow density is usually a sure sign of doughnut formation. The problem then becomes how to break up the island before it builds up to the point where the machine will shut down due to excessive torque.

If the doughnut has developed to the point that the thickener performance is severely handicapped, feed to the unit should be dropped, since it will probably require considerable time to clear out the 'doughnut'. Continued addition of solids will only aggravate the problem. If the mechanism is fitted with a lifting device, raising the rakes will frequently cause the island to slough off and flow, or slide, into discharge outlet.

It should be remembered, however, that raising the rakes removes the main support of the doughnut, and a greater weight of solids will have to be pushed along the thickener floor temporarily. This will cause an immediate increase in torque. Therefore, the extent to which the rakes should be raised at any given time must be conditioned by the percentage of torque already being used.

If the mechanism does not have a lifting device, the operator must use high pressure water or air lances to try to break up the island and move it to the discharge point. If this fails, the only alternative may be to shut down and dig out the unit. Doughnut formation is not always predictable, but some generalisations about it are discussed:

A large number of thickeners make use of synthetic polymers to increase performance. As polymer dosage is increased, there is frequently an increase in the underflow viscosity. There is a point at which the thickened solids lose their fluidity and the mechanism rake arms may no longer cause flow toward the discharge point.

Instead, a viscous, or gelatinous, mass tends to travel along in front of the rake arms, and this mass will slowly build up and start to accumulate in the rake arms. As this happens, those solids, which should move to the center of the tank, will be blocked by the 'stationary' mass. Additional residence time tends to consolidate the solids in this mass and make them more immovable. The net result is the formation of a fairly solid accumulation that slides along the floor of the thickener and eventually fills the rake truss itself.

If allowed to continue long enough, additional solids accumulate in front of the mass contained in the rake and the total accumulation can eventually grow to form a complete ring. This formation is that commonly referred to as a 'doughnut'. The island effectively blocks settled solids from the central discharge outlet, and any solids, which do reach the outlet, must pass up and over this island or short circuit directly from the feed inlet. With insufficient detention time in the thickener, a much lower solids concentration can result. Thus, the underflow becomes diluted slurry.

Polymers are not the only contributing cause of doughnut formation. It may also be a result of allowing the solids to stay in the thickener as long as possible to increase underflow density. However, this must be done with discretion, and successful application of this principle is dependant upon the type of solids being handled and the type and quantity of polymers being used. Finally a very important factor is to understand the thickener operation and to have the patience to allow changes to take place once corrective action has been taken.

Control of a High Rate Thickener on Gold Plant Tailings

The use of High Rate Thickeners has gained wide acceptance in the mineral treatment industries. The design of these units is characterised by an efficient deaeration and flocculation chamber and introduction of the flocculated feed solids into a preformed floc bed zone.

By these means the settling process is accelerated and consequently High Rate Thickeners achieve a significantly higher throughput per unit than conventional thickeners.

The object of a control system on a High Rate Thickener (HRT), as on a conventional thickener, is to obtain the required underflow density and overflow clarity at all feed conditions. The feed conditions, which may vary, include volumetric and mass feed rate, pulp density, particle size and particle type. A conventional thickener has a large volume and cross sectional area, and changes in performance occurs slowly, giving the operator time to observe and react to these changes to maintain control. On an HRT there is a much reduced residence time and therefore control parameters need to be reset more frequently. Although manual control is possible, the use of automatic control systems is therefore desirable to avoid excessive operator attention while optimising control of density and clarity.

Automatic control on a conventional thickener is usually achieved by an underflow density loop that regulates the rate of withdrawal of underflow. A turbidity meter is sometimes used to measure overflow clarity and regulate the addition of a coagulant or polymer flocculants. These measures are not adequate on a HRT; because they would not give optimum control and could lead to excessive flocculant use.

To achieve optimum operation in a HRT the floc bed level should be maintained above the feed inlet point in the thickener. This bed level has become the key variable around which most control systems have been designed. However a number of problems have occurred which has resulted in poor control of thickener performance.

HRT Control Systems

Briefly a HRT operates in the following way (see Fig 1): feed enters the feed well which is designed to promote deaeration and floc formation. If the feed has a high solids concentration, it is usually necessary to add dilution water to allow effective floc formation. Flocculant is injected into the feed and deaeration and flocculation occurs as the feed moves down the feed well. It leaves the feed well by impinging on the deflector cone, which imparts a horizontal velocity as it enters the body of the thickener.

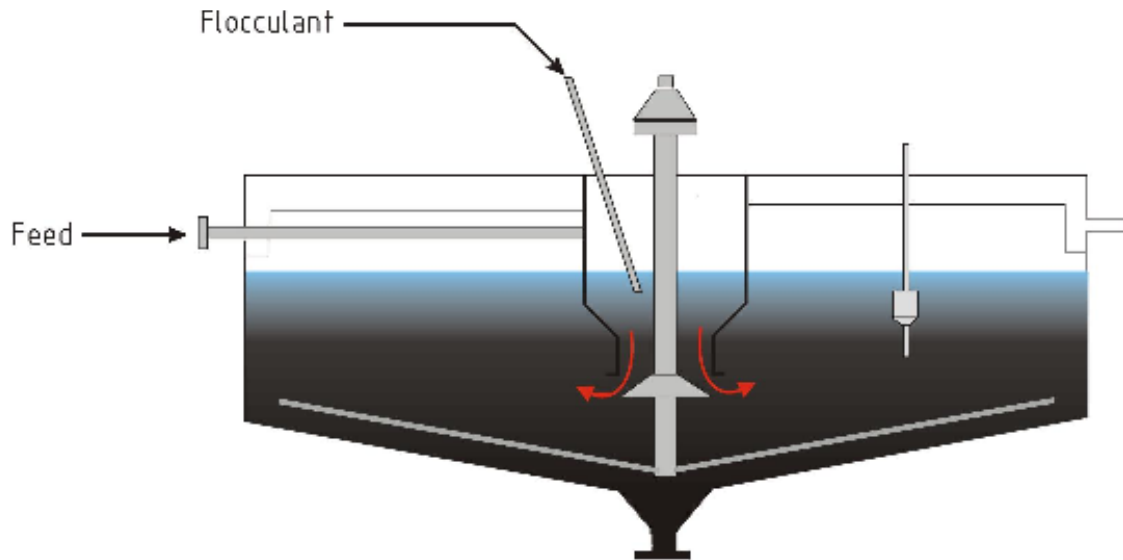

Fig. 1

Since the bed level is above the feed deflector the entering flocculated feed is distributed into the floc bed where further agglomeration takes place, resulting in accelerated settling of solids and filtering of the water as it moves upwards. A very distinct bed/water interface is formed which is characteristic of HRT operation.

The floc bed is not homogeneous but comprises a fluidized zone above the feed deflector and a compression zone around the rakes. As particles become agglomerated in the fluidized zone they settle into the compression zone where the action of the rakes assists in thickening. Thickened underflow is continuously removed from the thickener cone. The floc bed is therefore in a dynamic state, with the liquid moving upwards and suspending particles which are settling relative to the liquid. Removal of thickened solids via the underflow cone allows equilibrium to be attained and the pulp/liquid interface becomes stationary. However this equilibrium is disturbed if the solids settling rate changes or if the density or volume of the pulp feed changes.

Most HRT control systems are based on the regulation of underflow withdrawal rate to achieve control of bed level. Hence, when any of the above parameters change the underflow valve position is regulated to increase the underflow discharge if bed level rises and vice versa.

In order to regulate the solids settling rate, the degree of flocculation has to be controlled by regulating the flocculant addition rate in response to some measured variable. Since underflow density is the desired control variable, attempts have been made to use a density signal to control flocculation addition rate. The torque on the rake mechanism is related to the underflow density and has also been used for this purpose. The drawback with this approach is that both underflow density and torque change relatively slowly because changes in settling rate have to work their way through the compression zone. Hence, a time lag of up to 30 minutes can occur between a change in feed condition and response of this control loop.

Also, it has been found that torque is not only dependent on pulp density in the compression zone, but also affected by the depth of the compression zone, that is, it is related to the inventory within the thickener.

The result of this can be as follows: if the thickener feed rate increases, the bed level will start rising for two reasons, increased solids rate and reduced flocculant dosage relative to incoming solids. The underflow control loop increases underflow discharge rate; underflow density/torque eventually begins to decrease, and flocculant rate is increased. By this time, however, the feed rate may be back to normal and increased dosage would therefore result in a rapid drop in bed level. This would therefore start or set up a cycling or unstable control response.

Although this may indicate that a well – damped loop would give an improved control response by taking account of the inherent system lag, in practice this has proven difficult because the lag time varies with the bed mass of solids in thickener, which is not itself controlled by these means.

An improvement on this system is the use of mass flow measurement on the thickener feed to set the flocculant dosage, with the dosage set point being set by the underflow density. This allows the flocculant rate to respond instantly to changes in solids rate. The dosage can also be increased relative to volumetric rate, since an increased settling rate is required to compensate for the higher liquid “rise rate” in the thickener. This system has two major disadvantages:

It is expensive, since flow and density instruments and signal modifiers are required;
It does not respond well to changes in the ore type or nature of solids, e.g. a feed with a high clay content could require five times the flocculant rate relative to a low clay feed. Although the underflow density reset would eventually take care of this, the thickener would be out of control for a period.

The above control philosophy may be reversed, that is the underflow density used to regulate underflow rate and bed level to regulate flocculant rate. This system has been used on some gold tailing thickeners with some success, it is more responsive than underflow density control of flocculant rate, because bed level responds more rapidly to changes in flocculant rate. However, the inherent time lags in the system make it unstable unless the feed conditions change very slowly.

HRT Control System at Sunrise Dam Gold Mine

The control system installed in the SDGM thickener is shown in fig. 2 where the underflow density is controlled by a bed mass pressure probe and the flocculation rates controlled by a bed level probe. The control strategy based on bed mass is explained below.

Solid Mass Measurement

Since the depth of pulp + liquid at a point in the underflow cone of the thickener does not change during normal operation, it follows that measurement of the static pressure is a function only of pulp density. Therefore, by measuring the static pressure in the thickener cone, a signal that is a function of solids mass in the thickener is obtained.

If the zero point on the static pressure scale is set to be equivalent to a column of liquid with no solids present, the static pressure measurement is then linearly proportional to solids mass in the thickener.

A differential pressure transmitter is installed in the thickener cone and the pressure signal input to a PLC controller. This signal is then used to configure a control loop as shown in fig. 2, with the underflow valve regulation being controlled as a function of static pressure (i.e. solids mass in thickener). Bed level is used to regulate flocculant pump speed.

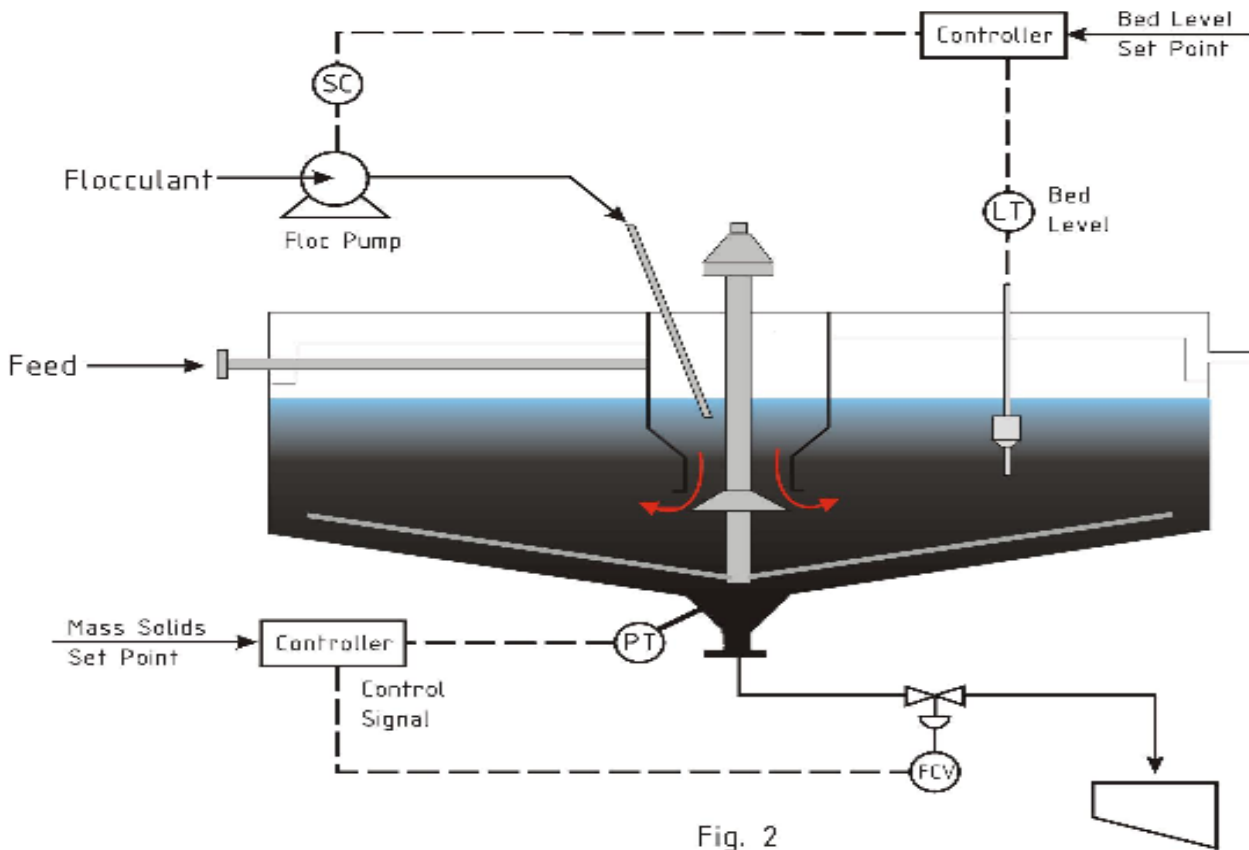

Fig. 2

Trouble Shooting Guide

Solids Overflow in Peripheral Launder

Problem or Indication	Cause	Corrective Action(s)
Thickener overflow water is either becoming clouded or is starting to slime over with solids.	Slow settling rate-not enough flocculant addition.	<ul style="list-style-type: none"> • Check settling in the feed well and adjust flocculant addition rate to suit (ie increase flocc addition).
	Flocculant pump failure	<ul style="list-style-type: none"> • Check pump operation • Change over to the standby flocculant pump.
	Bed level is too high.	<ul style="list-style-type: none"> • Lower the bed level by, increasing the underflow output rate (ie open the discharge valve further). • Divert the thickener feed to a bypass.
	Bed level lower than the bottom of the feed well.	<ul style="list-style-type: none"> • Increase the bed level (and density) above the bottom of the feed well. • Recirculate the thickener (for a short period only) if required.
	Faulty bed level indication (ie reading low when actually high)	<ul style="list-style-type: none"> • Manually check the bed level height. • Check and clean bed level probe.
	Blocked Underflow (usually hard-hats, gloves or tools).	<ul style="list-style-type: none"> • Back flush the thickener underflow lines with water. • If the flow is restricted by foreign objects the thickener will have to be emptied and cleaned out.
	Blocked Flocculant Spargers (Flocculant may solidify at very low flowrates).	<ul style="list-style-type: none"> • Remove flocculant spargers and clean out. • Dip marcy bucket in well and check settling rate.
	Chemicals in ore reacting with Flocculant, preventing flocculation.	<ul style="list-style-type: none"> • Carry out a settling test (with a one litre measuring cylinder) of the pulp in the feed well, if settling does not occur and all other conditions are OK then inform your supervisor.
	Lack of dilution water with the feed slurry.	<ul style="list-style-type: none"> • Increase the addition rate of dilution water.
	Too much dilution water (ie flocculant breakdown)	<ul style="list-style-type: none"> • Decrease the addition rate of dilution water.

Rapidly Rising Bed Level

Problem or Indication	Cause	Corrective Action(s)
Thickener bed level is rising rapidly and / or the thickener is grossly sliming over i.e. slurry is running over the overflow.	Check for cause of fault <ul style="list-style-type: none"> • Insufficient flocc • Flocc pump failure • Underflow ACV setpoint for pinch valve too slow • Underflow ACV failure • Too much dilution water 	<ul style="list-style-type: none"> • Quickly lower the bed level as below. • Reduce feed to thickener • Turn off the dilution water. • Open the underflow pinch valve ACV to stop the overflow. (use dump line if pinch valve ACV cannot be opened) • Inform your supervisor. • Start the feed into the thickener once the fault has been rectified.

Thickener Underflow Density Too Low

Problem or Indication	Cause	Corrective Action(s)
Thickener underflow density is running below the setpoint.	Underflow pinch control valve is opened too far.	<ul style="list-style-type: none"> • Check the status of the pinch Valve (it may be running in manual). • Increase bed mass which will close the pinch valve.
	The flocculant addition rate has slowed.	<ul style="list-style-type: none"> • Check the bed level position (check that the probe is functioning correctly). • If the flocculant addition rate is low and the bed level is rising then increase the flocculant addition rate.
	The dilution water system is not controlling.	<ul style="list-style-type: none"> • Check the dilution water system and adjust as necessary.
	No new feed into the thickener.	<ul style="list-style-type: none"> • Check the thickener bypass. • Check the feed into the thickener feed box.

Thickener Underflow Density Too High

Problem or Indication	Cause	Corrective Action(s)
Thickener underflow density is running above the setpoint.	Underflow ACV is not open far enough.	<ul style="list-style-type: none"> • Check the status of the ACV pump (it may be running in a fixed speed mode). • Increase the speed of the underflow pumps.
	The flocculant addition rate has increased (ie too high)	<ul style="list-style-type: none"> • Check the bed level position (check that the probe is functioning correctly). • If the flocculant addition rate is high and the bed level is falling then decrease the flocculant addition rate.
	The bed level may be falling back to its normal level.	<ul style="list-style-type: none"> • Monitor the bed level position (check that the probe is functioning correctly).
	The dilution water system is not controlling.	<ul style="list-style-type: none"> • Check the dilution water system and adjust as necessary.